

ACCESSORY BACKREST KIT



P/N 2884631-XXX; 2884632-XXX; 2884801-XXX;
2884802-XXX

BEFORE YOU BEGIN

Read these instructions and check to be sure all parts and tools are accounted for. Please retain these installation instructions for future reference and parts ordering information.

APPLICATION

Verify accessory fitment at www.indianmotorcycle.com.

IMPORTANT

The *Fixed Passenger Backrest Kit*, P/N 2884631-XXX cannot be used with the *Accessory Spool Kit*, P/N 2884925 or *Saddlebag Kit*, P/N 2884924.

REQUIRED SOLD SEPARATELY

NOTICE

XXX = Indian Motorcycle® color code (For example: 266 = Black)

LOCK & RIDE® PASSENGER BACKREST P/N 2884632-XXX

Only parts for installation of the Indian Motorcycle® Accessory Backrest Kit are included. Prior installation of the following additional kits are also required (sold separately):

- *Accessory Spool Kit*, P/N 2884925

PASSENGER BACKREST PAD P/N 2884801-XXX; 2884802-XXX

Only parts for installation of the Indian Motorcycle® Accessory Backrest Kit are included. Prior installation of the following additional kits are also required (sold separately):

- *Fixed Passenger Backrest Kit*, P/N 2884631-XXX or *Lock & Ride® Passenger Backrest Kit*, P/N 2884632-XXX

KIT CONTENTS

NOTICE

XXX = Indian Motorcycle® color code (For example: 266 = Black)

FIXED PASSENGER BACKREST P/N 2884631-XXX

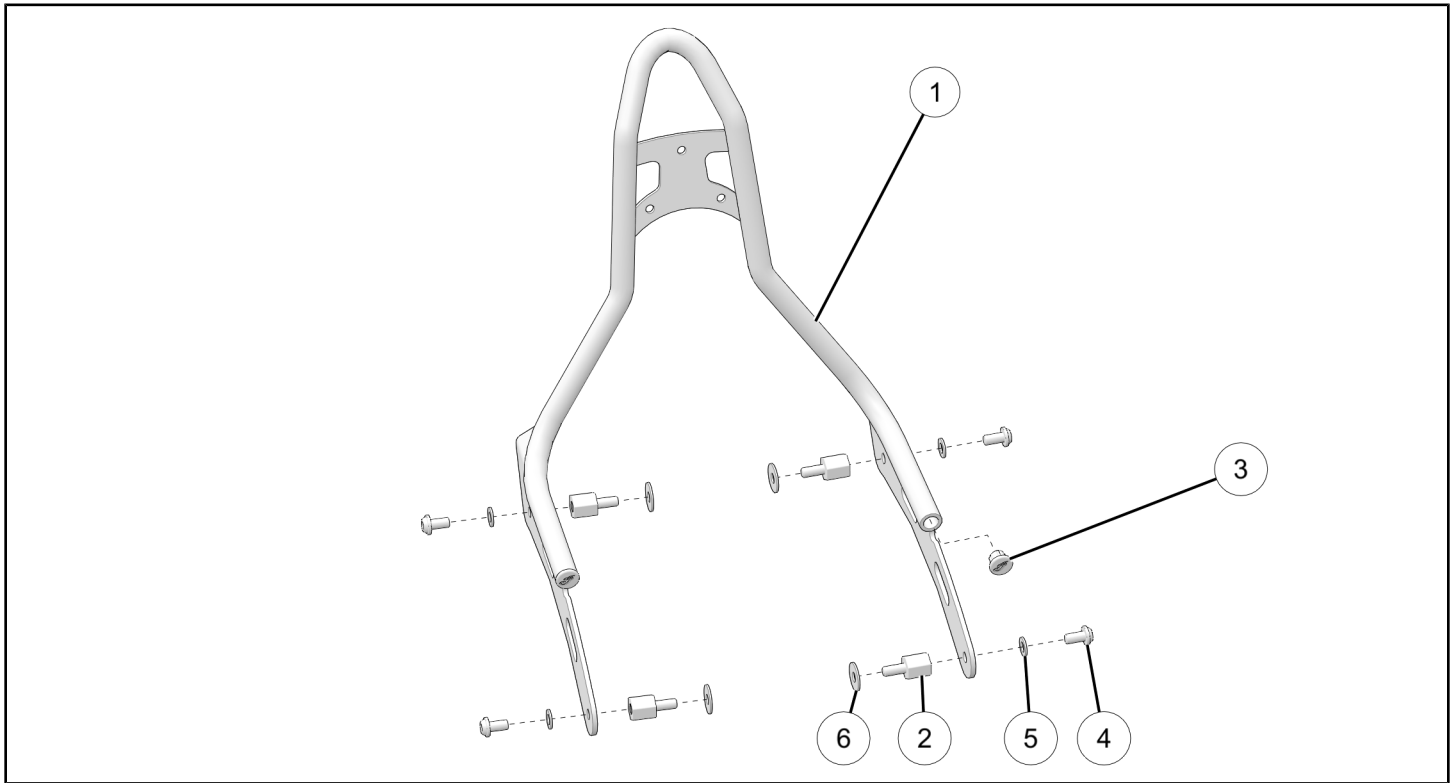

REF	QTY	PART DESCRIPTION	P/N AVAILABLE SEPARATELY
1	1	Fixed Passenger Backrest	N/A
2	4	Spacer	5143482
3	2	Tubing Plug	5417399
4	4	Screw, Hex Button Head, M8 x 1.25 x 16 mm	7520456
5	4	Washer, 8.4 x 16.0 x 1.6 mm	7556254
6	4	Washer, 8.4 x 24.0 x 2.0 mm	7556352

LOCK & RIDE® PASSENGER BACKREST P/N 2884632-XXX

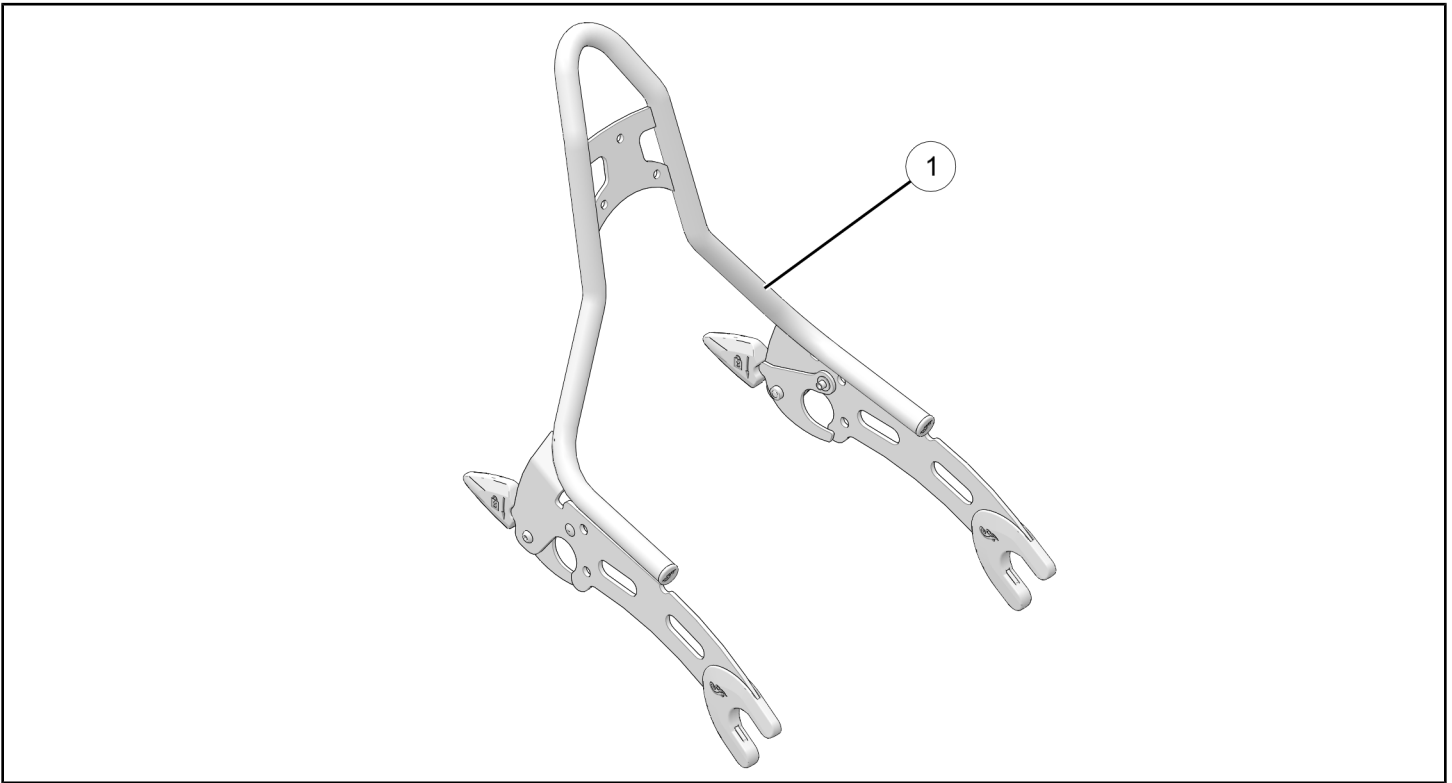

REF	QTY	PART DESCRIPTION	P/N AVAILABLE SEPARATELY
1	1	Lock & Ride® Passenger Backrest	N/A

PASSENGER BACKREST PAD P/N 2884801-XXX; 2884802-XXX

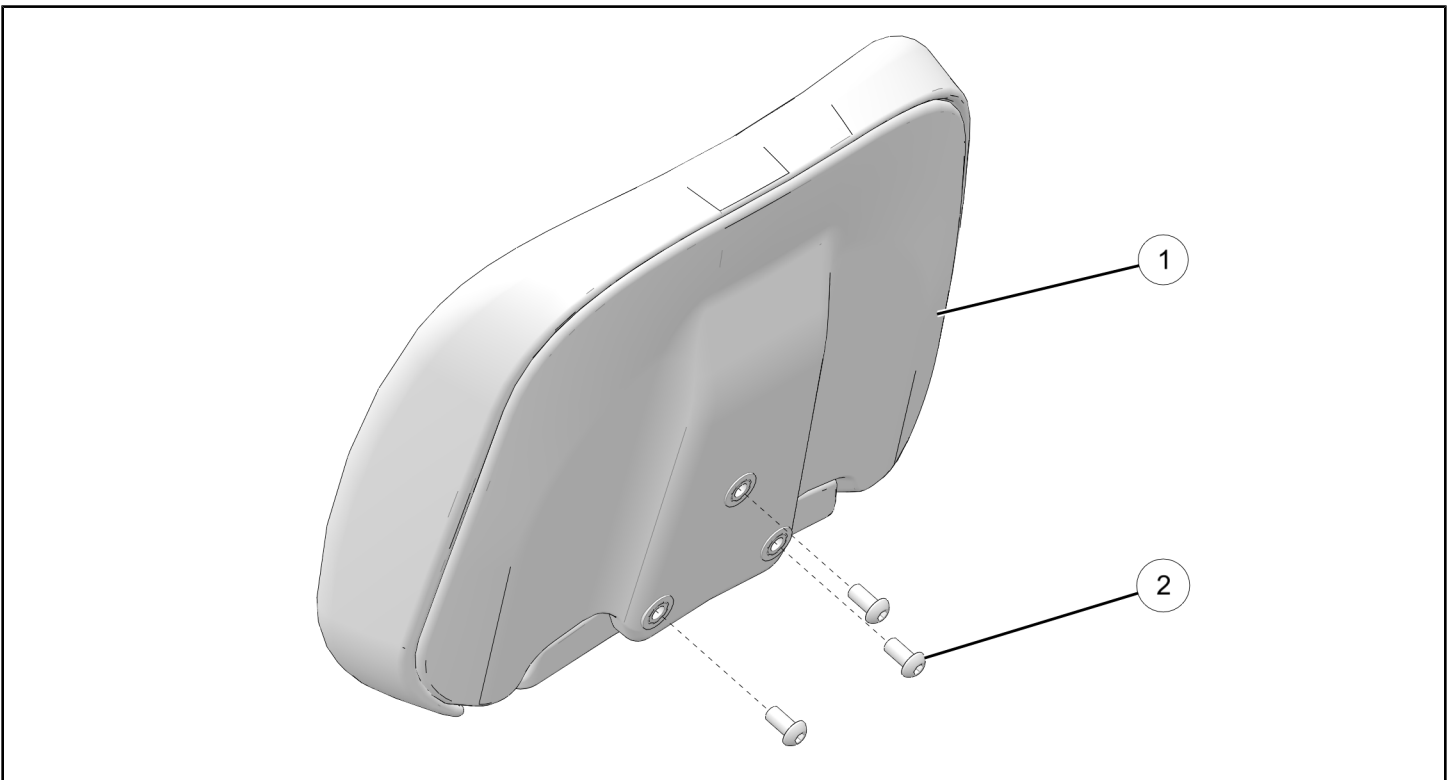

REF	QTY	PART DESCRIPTION	P/N AVAILABLE SEPARATELY
1	1	Passenger Backrest Pad (Kit P/N 2884801-XXX) Passenger Backrest Pad (Kit P/N 2884802-XXX)	N/A N/A
2	3	Screw, Hex Button Head, M6 x 1.0 x 12 mm	N/A

TOOLS REQUIRED

- Safety Glasses
- Hex Key Set, Metric
- Socket Set, Hex Bit, Metric
- Socket Set, Metric
- Torque Wrench

IMPORTANT

Your Indian Motorcycle® Accessory Backrest Kit is exclusively designed for your vehicle. Please read the installation instructions thoroughly before beginning. Installation is easier if the vehicle is clean and free of debris. For your safety, and to ensure a satisfactory installation, perform all installation steps correctly in the sequence shown.

INSTALLATION INSTRUCTIONS

VEHICLE PREPARATION

GENERAL

1. Park motorcycle on a flat surface, fully extend kickstand, and make sure vehicle is stable.
2. Turn key or ignition switch to OFF position and remove key. If equipped with keyless fob, remove fob from proximity of vehicle.

ACCESSORY INSTALLATION

FIXED PASSENGER BACKREST P/N 2884631-XXX

IMPORTANT

Install one spacer at a time so that fender does not move during installation.

1. Remove rear fender screw (A) and metal bushing (B).

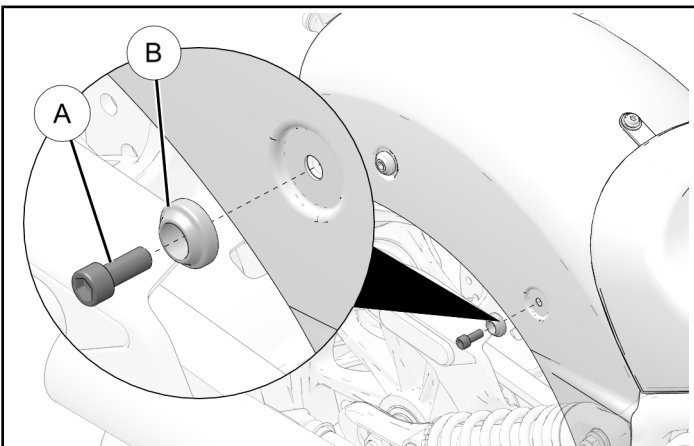

2. Install washer (6) and spacer (2). Torque spacers to specification.

TORQUE

Backrest Spacer (2):
18 ft-lbs (25 N·m)

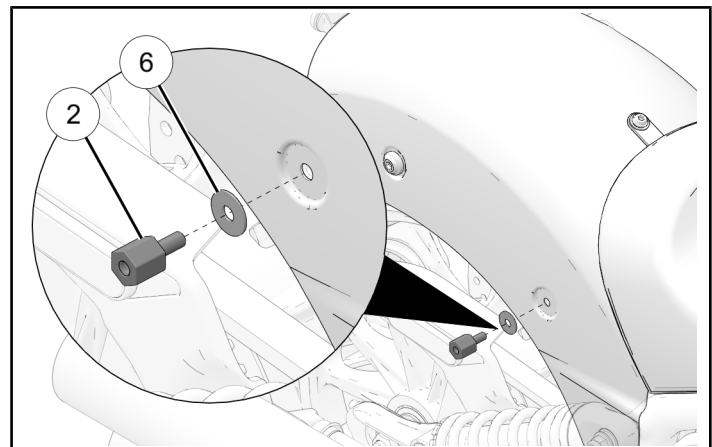

3. Install backrest ① and align mounting holes with spacers. Install washers ⑤ and screws ④. Torque screws to specification.

TORQUE

Backrest Mounting Screws ④:
13 ft-lbs (18 N·m)

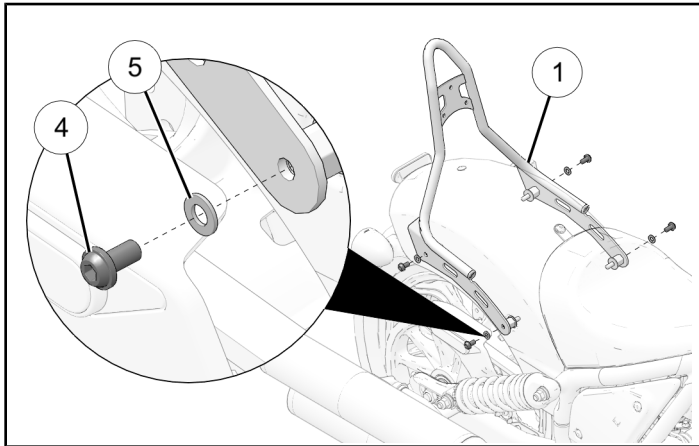

**LOCK & RIDE® PASSENGER BACKREST
 P/N 2884632-XXX**

1. Remove and keep the safety screws (A) from backrest Lock & Ride® levers (B). Open the Lock & Ride® levers.

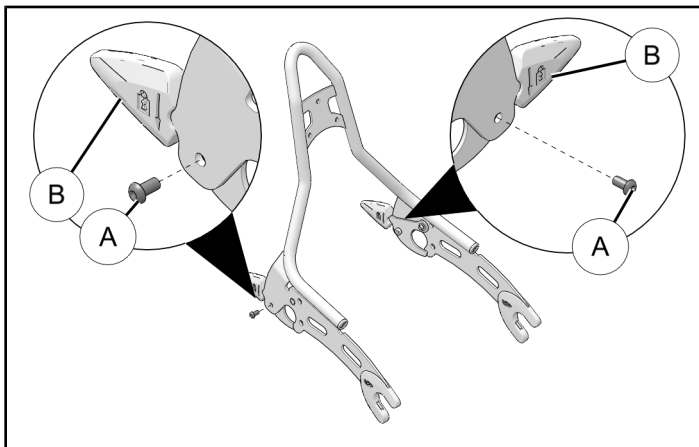

2. Install the backrest ① front forks to front spools.

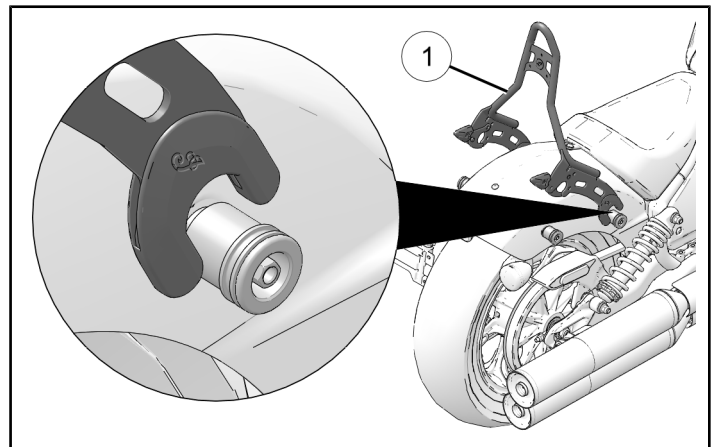

3. Move rear of backrest ① downward to engage rear spools.

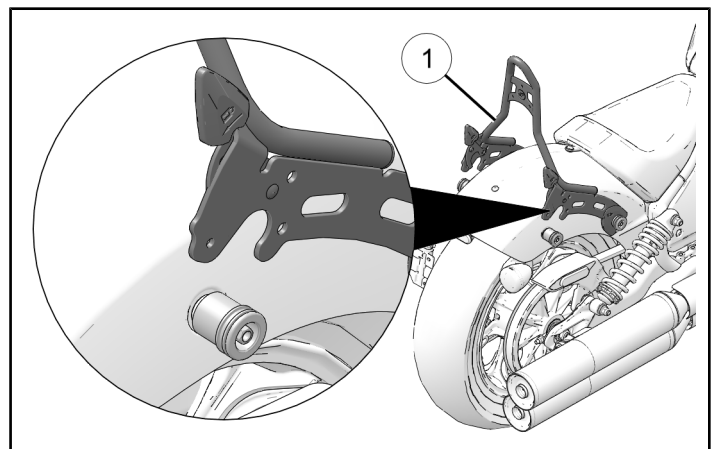

4. Close the backrest Lock & Ride® levers (B) and install the retained safety screws (A). Torque to specification.

TORQUE

Safety Screws (A):
88 in-lbs (10 N·m)

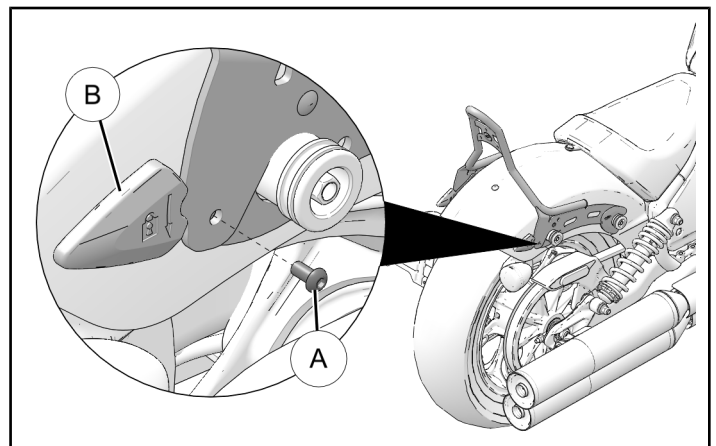

PASSENGER BACKREST PAD
P/N 2884801-XXX; 2884802-XXX

1. Install the backrest pad ① to the backrest tubing and align mounting holes. Install backrest mounting screws ② and torque to specification.

TORQUE

Backrest Pad Mounting Screws ②:
53 in-lbs (6 N·m)

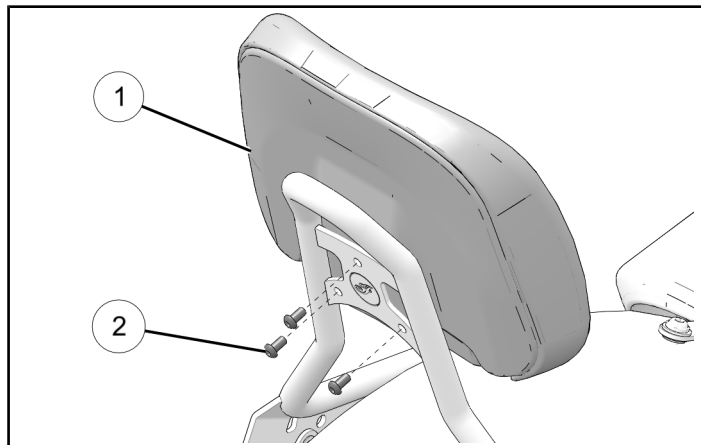

INSTRUCTION FEEDBACK FORM

A feedback form has been created for the installer to provide any comments, questions or concerns about the installation instructions. The form is viewable on mobile devices by scanning the QR code or by clicking [HERE](#) if viewing on a PC.

