

# Rhino Grip XLR Double - Polaris UTV Lock & Ride Lock & Ride MAX

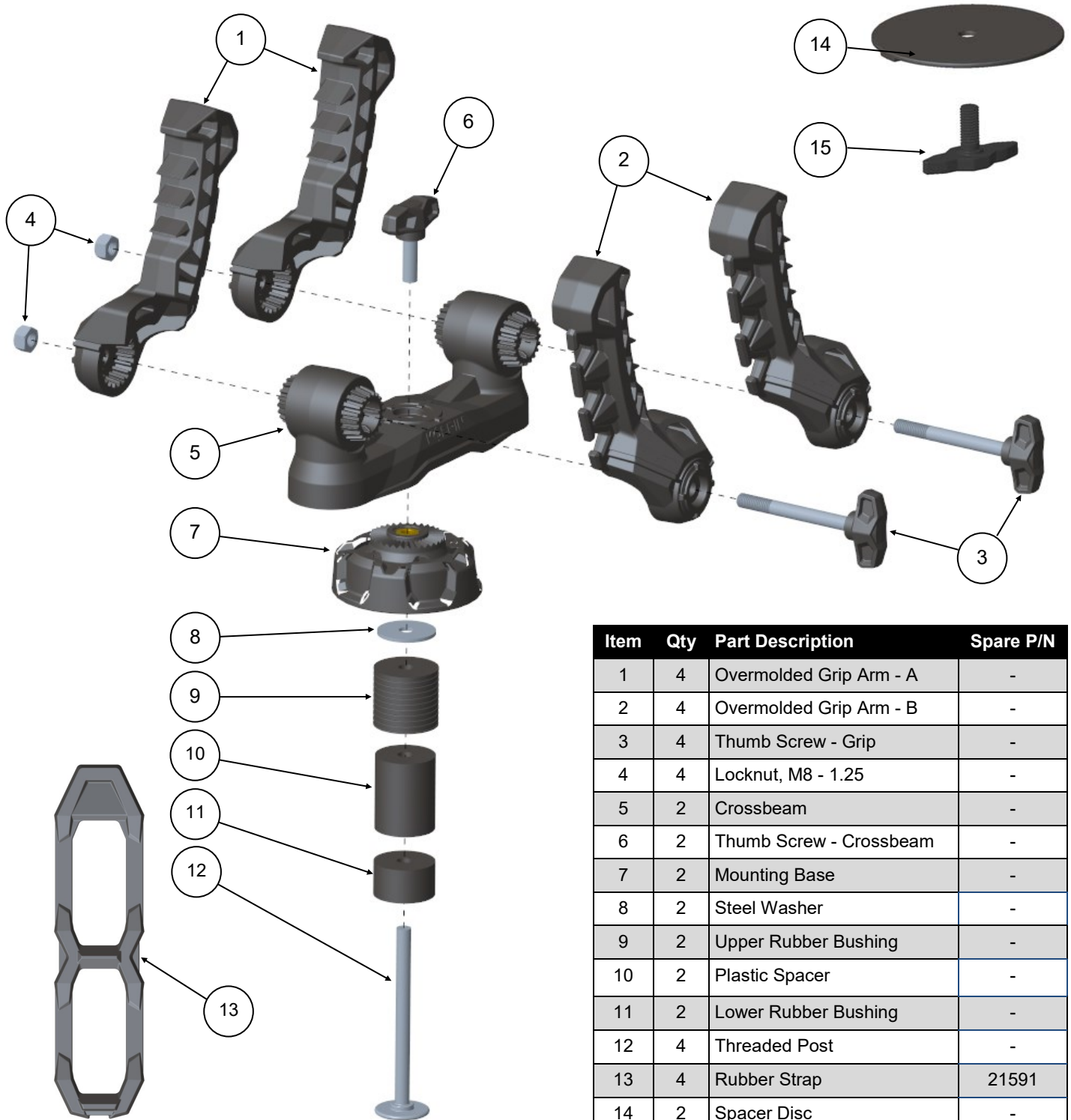

## Product Instructions | Part No: 21555

Before you begin, read these instructions and check to be sure all parts and tools are accounted for. Please retain these instructions for future reference and part ordering information. Note: If any hardware is missing, do not return to the store. Call us to help, toll free at 1-877-956-5746.



Item	Qty	Part Description	Spare P/N
1	4	Overmolded Grip Arm - A	-
2	4	Overmolded Grip Arm - B	-
3	4	Thumb Screw - Grip	-
4	4	Locknut, M8 - 1.25	-
5	2	Crossbeam	-
6	2	Thumb Screw - Crossbeam	-
7	2	Mounting Base	-
8	2	Steel Washer	-
9	2	Upper Rubber Bushing	-
10	2	Plastic Spacer	-
11	2	Lower Rubber Bushing	-
12	4	Threaded Post	-
13	4	Rubber Strap	21591
14	2	Spacer Disc	-
15	2	T-Bolt	-

Kolpin Outdoors, Inc. | 9955 59th Ave N | Plymouth, MN 55442

(877) 956-5746 or (763) 478-5800 | [kolpin.com](http://kolpin.com) | [customerservice@kolpin.com](mailto:customerservice@kolpin.com)

## Mounting Instructions: Lock & Ride (Items 8 thru 12)

1. Attach the Lock & Ride components [Items 8 thru 12] into the threaded hole on the bottom of the Mounting Base [Item 7].
2. Adjust the tightness of the Upper & Lower Rubber Bushings [Items 9 & 11] until it expands enough to make light contact with the Lock & Ride hole on the vehicle but can still be pushed in far enough so the bottom of the Mounting Base [Item 7] makes contact with the vehicle bed rail.
3. Place into vehicle's Lock & Ride hole and push down while turning the Mounting Base clockwise to tighten. The Rubber Bushings will expand and draw the Mounting Base tight to the vehicle bed rail.

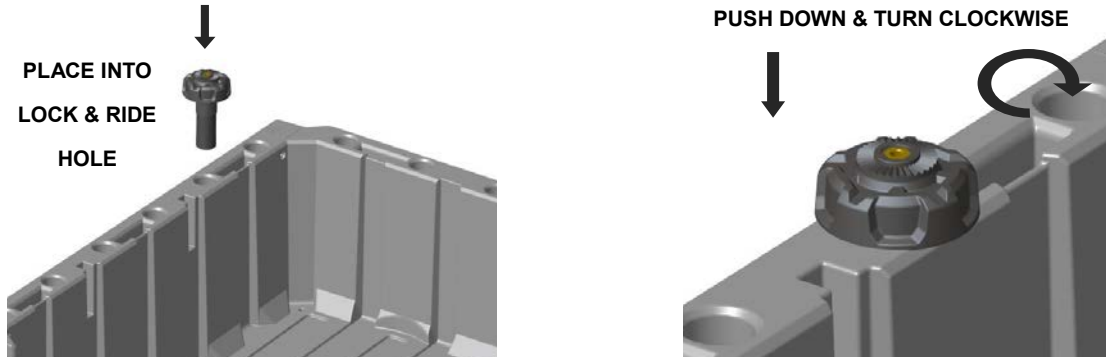

4. Attach Crossbeam [Item 5] to the Mounting Base [Item 7] using the Thumb Screw [Item 6]. **Tighten Thumb Screw securely.** The upper Grip Arms [Items 1 & 2] can be left assembled or removed during install.
5. To remove from vehicle, turn the Mounting Base counter-clockwise until the Rhino Grip can be pulled out of the Lock & Ride hole.

## Mounting Instructions: Lock & Ride MAX (Items 14 and 15)

1. Insert the Spacer Disc [Item 14] and T-Bolt [Item 15] into the bottom of the Rhino Grip as shown, leaving enough of a gap for the T-Bolt to drop into the Lock & Ride MAX rail.
2. Insert the T-Bolt [Item 15] into the Lock & Ride MAX access hole and slide into the desired position along the rail. Assure that the track feature on the bottom of the Spacer Disc is positioned inside the opening of the rail.
3. Turn the Rhino Grip Base clockwise until it is tight.
4. Once the Rhino Grip Base is tight, re-adjust the Rhino Grip Arms to the desired position.

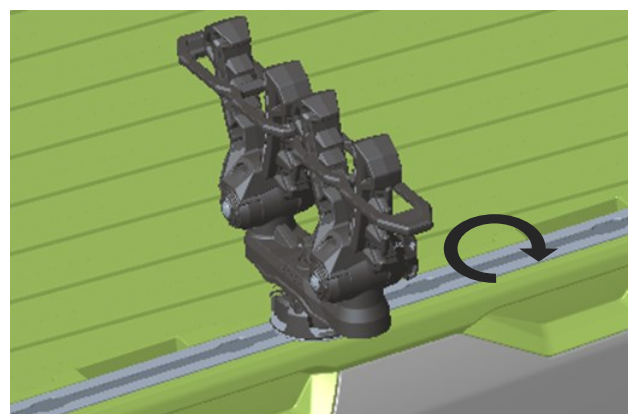
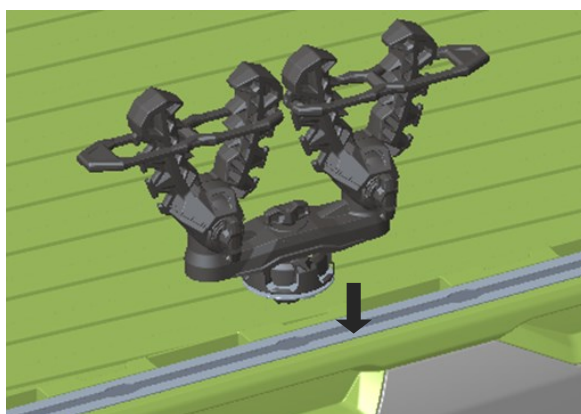

### WARNING

Do not exceed 20 lbs carrying capacity or damage may occur.

## **Use and Care Information:**

Check the accessory mounts frequently and retighten if necessary. Replace this accessory with a new one if it is damaged or discolored excessively. When this accessory becomes dirty, rinse thoroughly with cool water to remove loose dirt, then wipe with a clean cloth or sponge. Never use petroleum solvents such as gasoline, thinner, benzene, acid or alkaline cleaners. Its recommended to keep out of direct sunlight exposure during long periods of time.

For additional assistance, please contact Kolpin customer service department at (877) 956-5746 or (763) 478-5800 or email [customerservice@kolpin.com](mailto:customerservice@kolpin.com)

## **One Year Limited Warranty**

For the period of one (1) year from the purchase date, Kolpin will replace for the original purchaser, free of charge, any part or parts found upon examination by Kolpin to be defective in material, workmanship, or both.

All transportation costs incurred submitting product to Kolpin for warranty consideration must be borne by the purchaser. If Kolpin determines that the product must be returned to the factory for credit, please call 1-877-956-5746 for a Return Merchandise Authorization (RMA) number and shipping instructions.

This warranty does not apply to parts that have been damaged by accident, alteration, abuse, improper maintenance, normal wear, or other causes beyond the manufacturer's control. In order to protect you and your ATV, certain parts of the accessory system and/or hardware are designed to fail when the equipment is over-stressed. Parts that are lost due to loosening and