



# WINCH MOUNT KIT

FOR KAWASAKI MULE PRO-FX / FXT / FXR / DX / DXT

P/N 25-2370

## ASSEMBLY / OWNERS MANUAL

Application

WINCH KIT NO. 25-9xxx

Before you begin, please read these instructions and check to be sure all parts and tools are accounted for. The following instructions contain details required to install and service the contents of this kit.

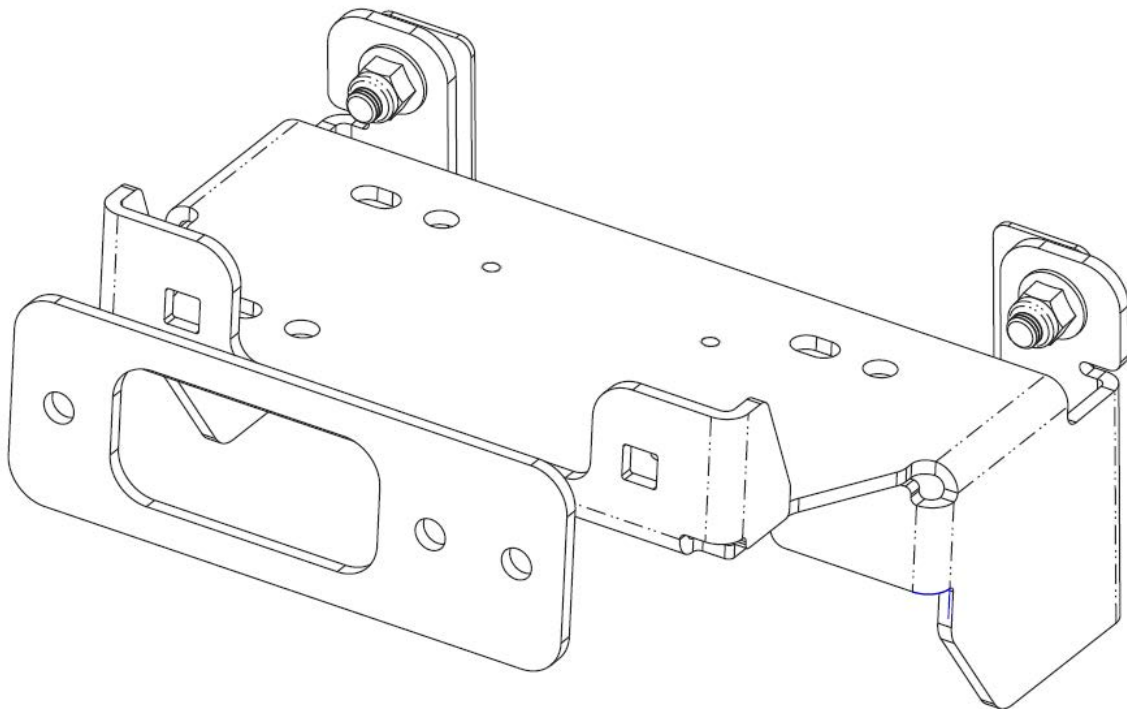

# OPERATING INSTRUCTIONS

Congratulations! You've just purchased the most durable accessory component in the industry. Our accessories work great all year round! With proper care and maintenance, your Kolpin accessory will last for years to come! Please read and understand all assembly instructions, notices and warnings before assembling and using your Kolpin accessory.

## Follow these guidelines to ensure a successful and satisfactory installation:

Read, understand this manual before beginning installation

Periodically check for wear and tightness of all fasteners.

Replace or re-torque fasteners as necessary.

## SAFETY & GENERAL PRODUCT INFORMATION

Kolpin accessories are designed with your safety in mind.

In order to protect you and your vehicle, certain parts of the accessory and/or hardware may be designed to collapse or break when the equipment is over-stressed.

Kolpin winch mount kits are designed to be compatible with Kolpin and Cycle Country winches along with many others, but may not be compatible with some winches. Kolpin winch mount kits have design features that benefit snow plow applications.



### **! DANGER ! ! WARNING ! ! CAUTION !**

#### **To avoid personal injury or damage to your vehicle:**

Read and understand all notices for:

Caution

Warning

Danger

Follow instructions for your vehicle, winch, winch mount and other items used in combination with this product.

Do not winch unsecured loads at any time.

Disconnect battery during winch installation or service to prevent electrical hazards.

Do not lift loads overhead.

Do not exceed the load capacity of the winch.

Always wear gloves when handling wire winch cable.

Do not use your winch or winch mount for towing.

Do not shock load the winch, cable or winch mount.

Keep fingers, hands and loose clothing away from roller fairlead and winch cable drum when in use.

### Kit Contents:

Item	Qty	Part Description	Part Number
1	1	Winch Mount Plate	-
2	2	Mounting Bolt Plate	-
3	4	Hex Flange Locknut, Zinc Plated, M10-1.5	-
4	1	Fairlead Adapter Plate	CYC6425
5	1	Instruction Guide (not shown)	-

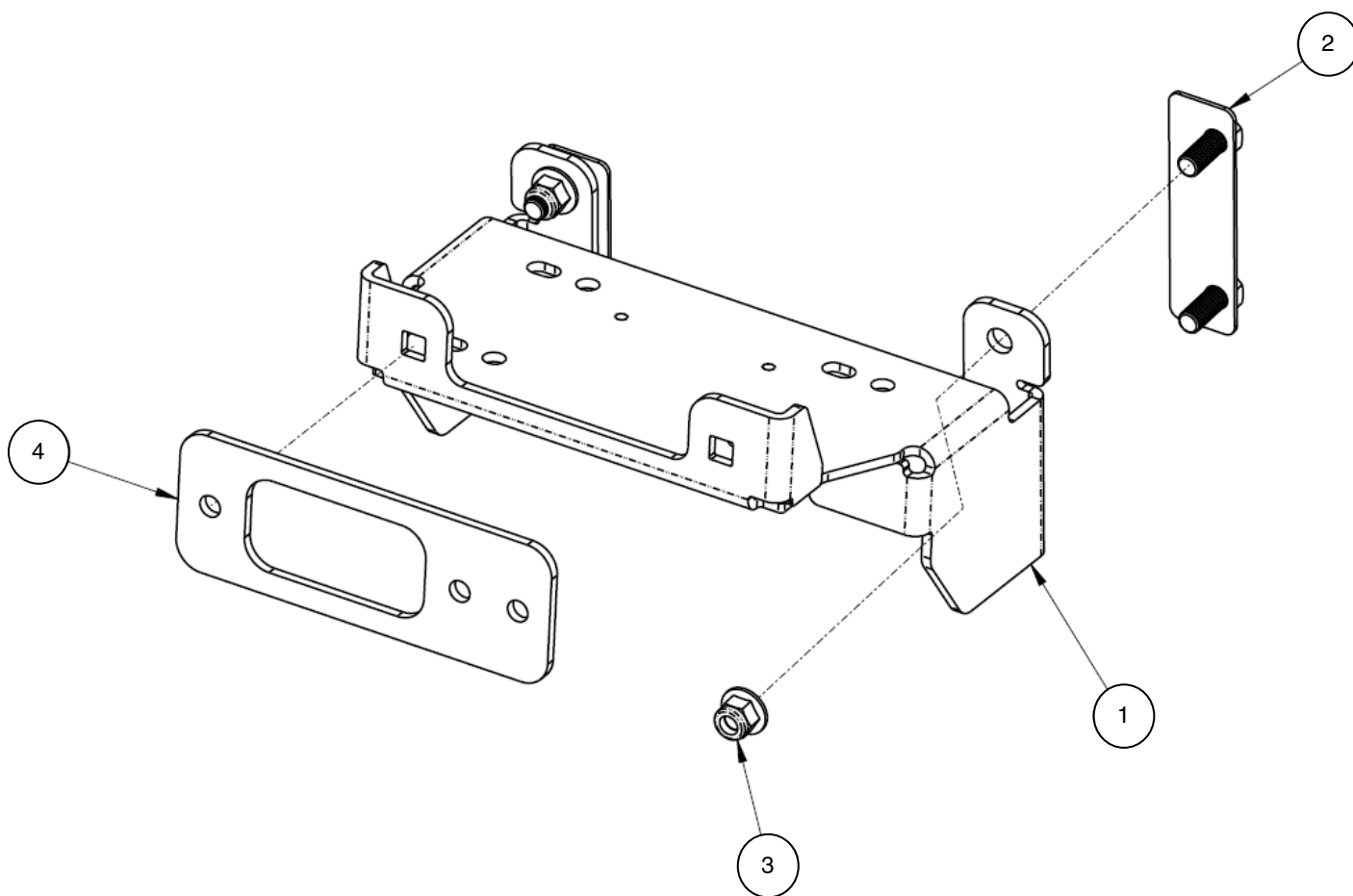

## BEFORE YOU BEGIN:

- Your Kolpin accessory is exclusively designed for your vehicle
- Please read and understand all instructions
- Verify all parts and tools are accounted for
- To ensure a satisfactory installation, follow all steps correctly and in the sequence described
- Keep these instructions for future reference or for informational requests
- To facilitate installation, make sure that your vehicle is clean and free of debris
- All directions referring to right and left are when the rider is sitting on the machine

## TOOLS REQUIRED:

- Metric Wrench set
- Metric Socket set
- Pliers
- Metric Hex Allen Key Wrench or Socket set
- Do not use impact tools to install hardware

## APPROXIMATE ASSEMBLY TIME: 30 minutes

Note: If any hardware is missing, do not return to the store. Call us to help, Toll Free 1-877-956-5746.

Mount bracket (item #1) has pre-drilled holes for mounting Kolpin contactor (provided with winch kit) onto underside of bracket as shown in image to the right.



## MULE PREPARATION:

1. Shift vehicle transmission into NUETRAL and engage PARKING BRAKE. Turn key to OFF position and remove from vehicle.
2. To gain access to electrical connections, turn the hood knobs, pull upwards to release.
3. Locate the battery box, release clips and remove cover. Disconnect black (negative) and red (positive) cables from battery. (See illustrations 1-1 and 1-2).

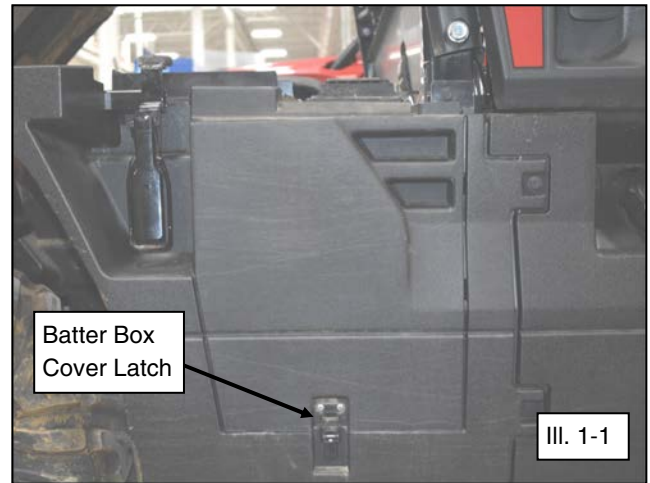

**⚠ WARNING ⚠**

**ALWAYS** disconnect black negative (-) cable from battery **FIRST**. Failure to do so will result in high current electrical arc, and may result in battery explosion if tool touches grounded frame. Death or serious injury may occur.

4. Remove the bumper screws from each upper side, the three lower screw and front bumper as shown. Save all for re-install later. Easy access is gained to install parts and to use tools is gained by removing this bumper. (See illustration 1-3). **Note, the front bumper weighs over 25 lbs. (12 kg), provide adequate support for bumper before removing final screws.**

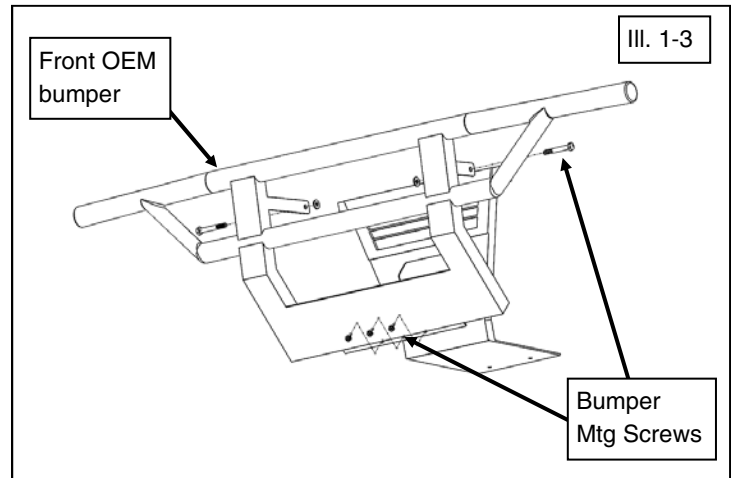

## MULE WINCH INSTALLATION:

5. Install the winch bracket (item #1) to the vehicle frame. Insert the bolt plates (item #2) thru vehicle frame from backside and thru holes in the mount plate. Fasten mount plate with M10 locknuts (item #3) as shown. (See illustrations 1-4 and 1-5).
6. Tighten to specifications.

**T = T**

**10MM FASTENER TORQUE:**  
34 ft. lbs. (46 Nm)

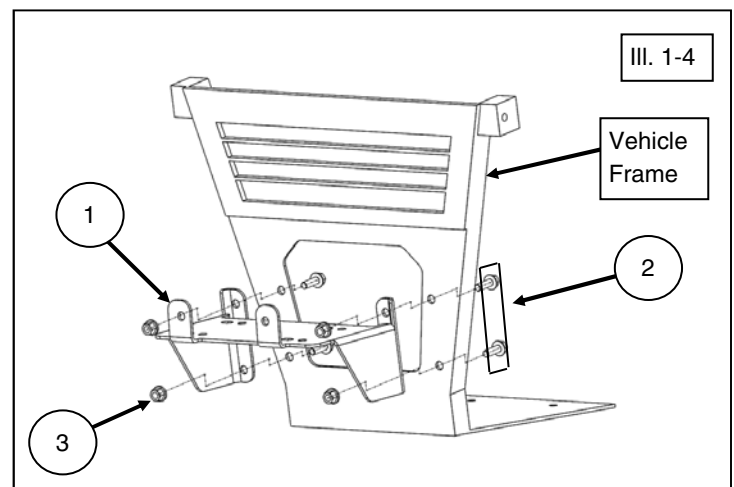
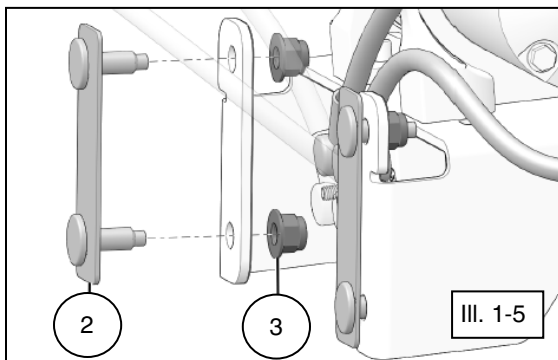

## MULE WINCH INSTALLATION

(continued):

7. Using the M8 hardware (provided with winch kit), attach the winch to the mounting bracket (item #1) as shown. (See illustration 1-6).  
**Note, the Kolpin winch mount 25-2370 has two winch mounting options. One hole pattern for standard width winches and one hole pattern for wide mount winches.**
8. Attach the fairlead adapter plate (item #4) to the winch bracket as shown using M8 screw and M8 locknut (provided with winch kit). (See illustration 1-7). **Note, this step is not required if using wide pattern roller fairlead (not included, sold separately as PN 85087).**
9. Attach roller fairlead (supplied with winch) using the M8 screws (provided with winch kit) and M8 locknut (provided with winch kit) to the fairlead adapter plate/ winch bracket with the warning decal facing up so it is readable. (See illustration 1-7).
10. Tighten M8 hardware to specification.

 = T
<b>8MM FASTENER TORQUE:</b> 17 ft. lbs. (23 Nm)

11. Using the OEM hardware, reinstall the front bumper to the vehicle frame. All hardware can be tightened to OEM specifications. (See illustration 1-10).

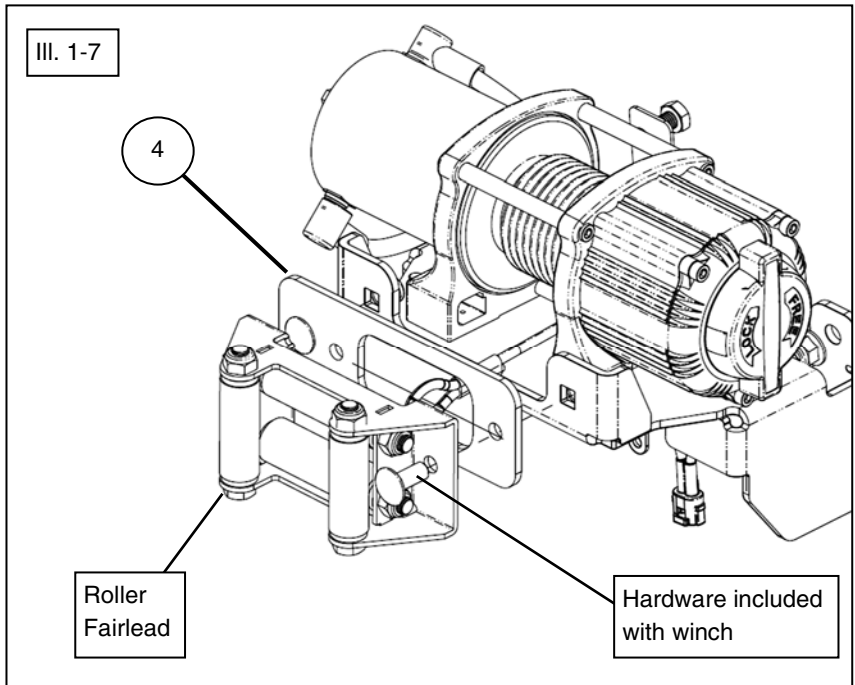
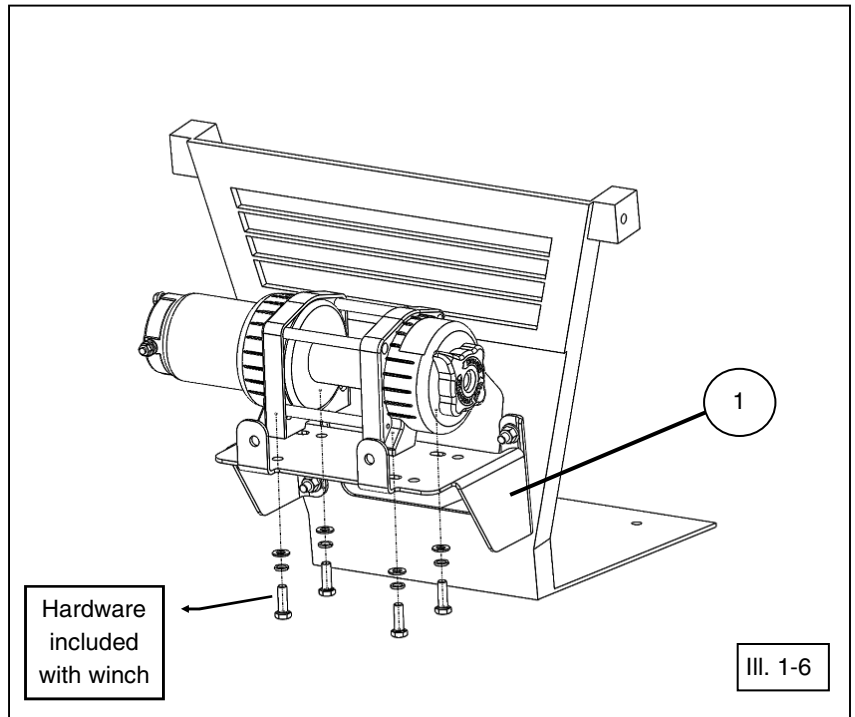



## WINCH CABLE WRAP INSTALLATION ON SPOOL DRUM:

12. The winch cable or rope should be wrapped around spool drum, feeding from top, as shown. Spooling the cable as shown will prolong cable life and enhance winch performance. (See illustration 1-9).
13. Connect the hook to cable or rope by using hardware included in winch kit. (See illustrations 1-8 and 1-10).

## WINCH WIRING AND CONNECTIONS:

14. Using the winch kit instructions, route and connect the electrical cables and components for the winch system. Check that all wires are free to move and not pinched between the vehicle chassis and the winch-bumper assembly.
15. The Contactor (included with winch kit), can be installed to the bottom of the winch bracket (item #1) as shown. The blue and yellow power cables (included with winch kit) can be pulled up behind the radiator. (**Note, the rubber protector terminal boots need to be installed over all of the power cables terminal ends (red and black boots not shown for clarity).**)
16. Confirm that all wiring is correct.
17. Confirm that there are no exposed wires or terminals.
18. All loose wires need to be wrapped tight, and secured away from moving parts and heat sources.
19. Reconnect the main vehicle power cables and the winch power red (positive) and black (negative) cables to battery terminals at this time using original hardware.
20. Reinstall the hood and battery box cover.
21. With vehicle key in the ON position, check winch for proper operation.

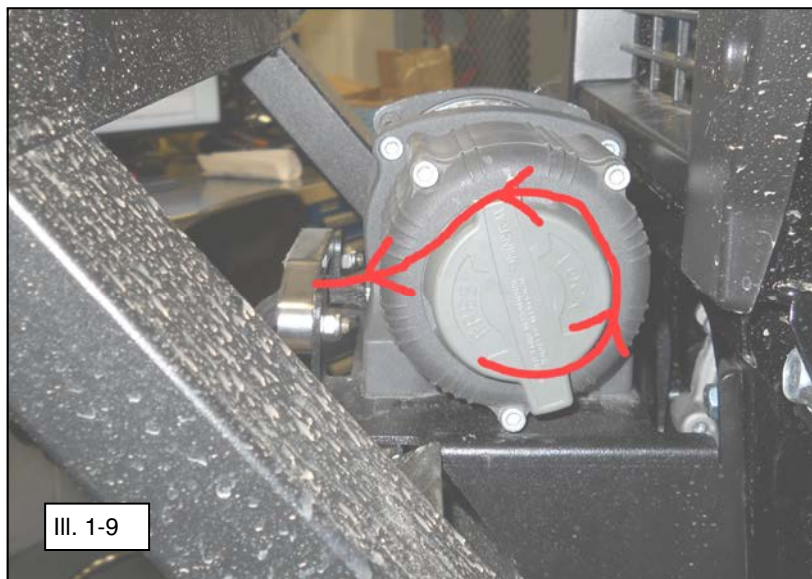

III. 1-9

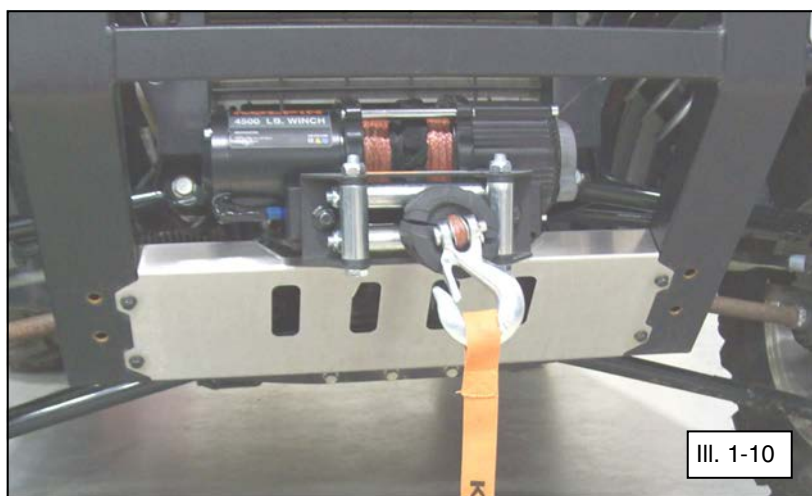

III. 1-10

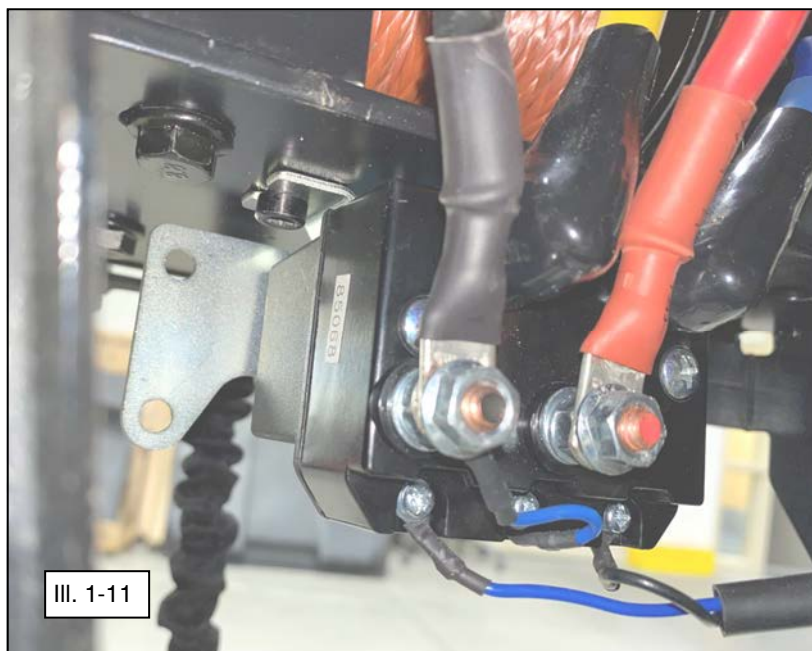

III. 1-11



## One Year Limited Warranty

For the period of one (1) year from the purchase date, Kolpin will replace for the original purchaser, free of charge, any part or parts found upon examination by Kolpin to be defective in material, workmanship, or both.

All transportation costs incurred submitting product to Kolpin for warranty consideration must be borne by the purchaser. If Kolpin determines that the product must be returned to the factory for credit, please call 1-877-956-5746 for a Return Merchandise Authorization (RMA) number and shipping instructions.

This warranty does not apply to parts that have been damaged by accident, alteration, abuse, improper maintenance, normal wear, or other causes beyond the manufacturer's control. In order to protect you and your ATV, certain parts of the system and/or hardware are designed to fail when the equipment is over-stressed. Parts that are lost due to loosening and improper maintenance are not covered under warranty. This warranty does not cover removal or reinstallation labor fees of the plow system and related components.

Peripheral products such as engines, electric motors, and actuators may carry an original manufacturer's warranty. Most hardware is general in nature and is easily obtained locally. Be sure to replace with minimum metric class 8.8 specification.

**Kolpin Outdoors, Inc.**

**Telephone: (763)-478-5800**

**Toll Free: (877)-956-5746**

**Fax Number: (800)-245-7569**

**[www.kolpin.com](http://www.kolpin.com)**

**Email: [customerservice@kolpin.com](mailto:customerservice@kolpin.com)**