



# WINCH MOUNT KIT

FOR POLARIS SPORTSMAN / ACE

P/N 25-3410

ASSEMBLY / OWNERS MANUAL

Application

WINCH KIT NO. 25-9xxx

Before you begin, please read these instructions and check to be sure all parts and tools are accounted for. The following instructions contain details required to install and service the contents of this kit.

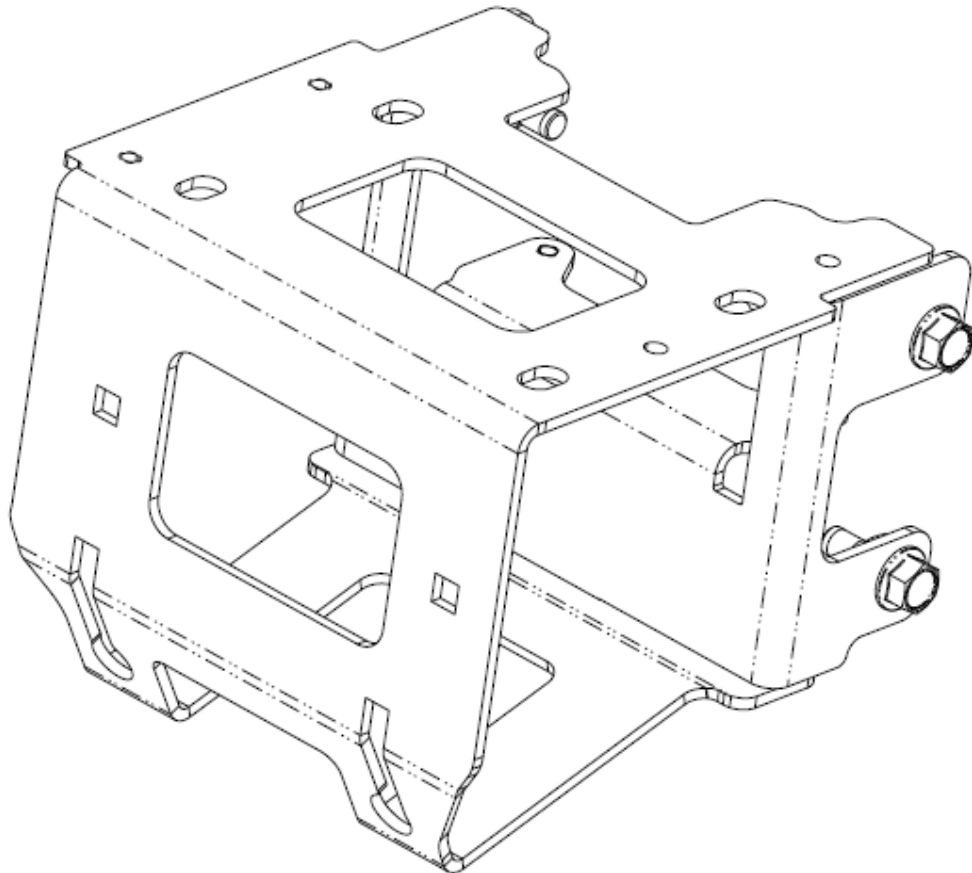

# OPERATING INSTRUCTIONS

Congratulations! You've just purchased the most durable accessory component in the industry. Our accessories work great all year round! With proper care and maintenance, your Kolpin accessory will last for years to come! Please read and understand all assembly instructions, notices and warnings before assembling and using your Kolpin accessory.

## Follow these guidelines to ensure a successful and satisfactory installation:

Read, understand this manual before beginning installation

Periodically check for wear and tightness of all fasteners.

Replace or re-torque fasteners as necessary.

## SAFETY & GENERAL PRODUCT INFORMATION

Kolpin accessories are designed with your safety in mind.

In order to protect you and your vehicle, certain parts of the accessory and/or hardware may be designed to collapse or break when the equipment is over-stressed.

Kolpin winch mount kits are designed to be compatible with Kolpin and Cycle Country winches along with many others, but may not be compatible with some winches. Kolpin winch mount kits have design features that benefit snow plow applications.



### **! DANGER ! ! WARNING ! ! CAUTION !**

#### **To avoid personal injury or damage to your vehicle:**

Read and understand all notices for:

Caution

Warning

Danger

Follow instructions for your vehicle, winch, winch mount and other items used in combination with this product.

Do not winch unsecured loads at any time.

Disconnect battery during winch installation or service to prevent electrical hazards.

Do not lift loads overhead.

Do not exceed the load capacity of the winch.

Always wear gloves when handling wire winch cable.

Do not use your winch or winch mount for towing.

Do not shock load the winch, cable or winch mount.

Keep fingers, hands and loose clothing away from roller fairlead and winch cable drum when in use.

## Kit Contents:

Item	Qty	Part Description	Part Number
1	1	Winch Bracket Weldment, Sportsman ATV	-
2	4	Hex Flange Bolts, Zinc Plated, M8-1.25 x 25mm LG	-
3	1	Instruction Guide (not shown)	-

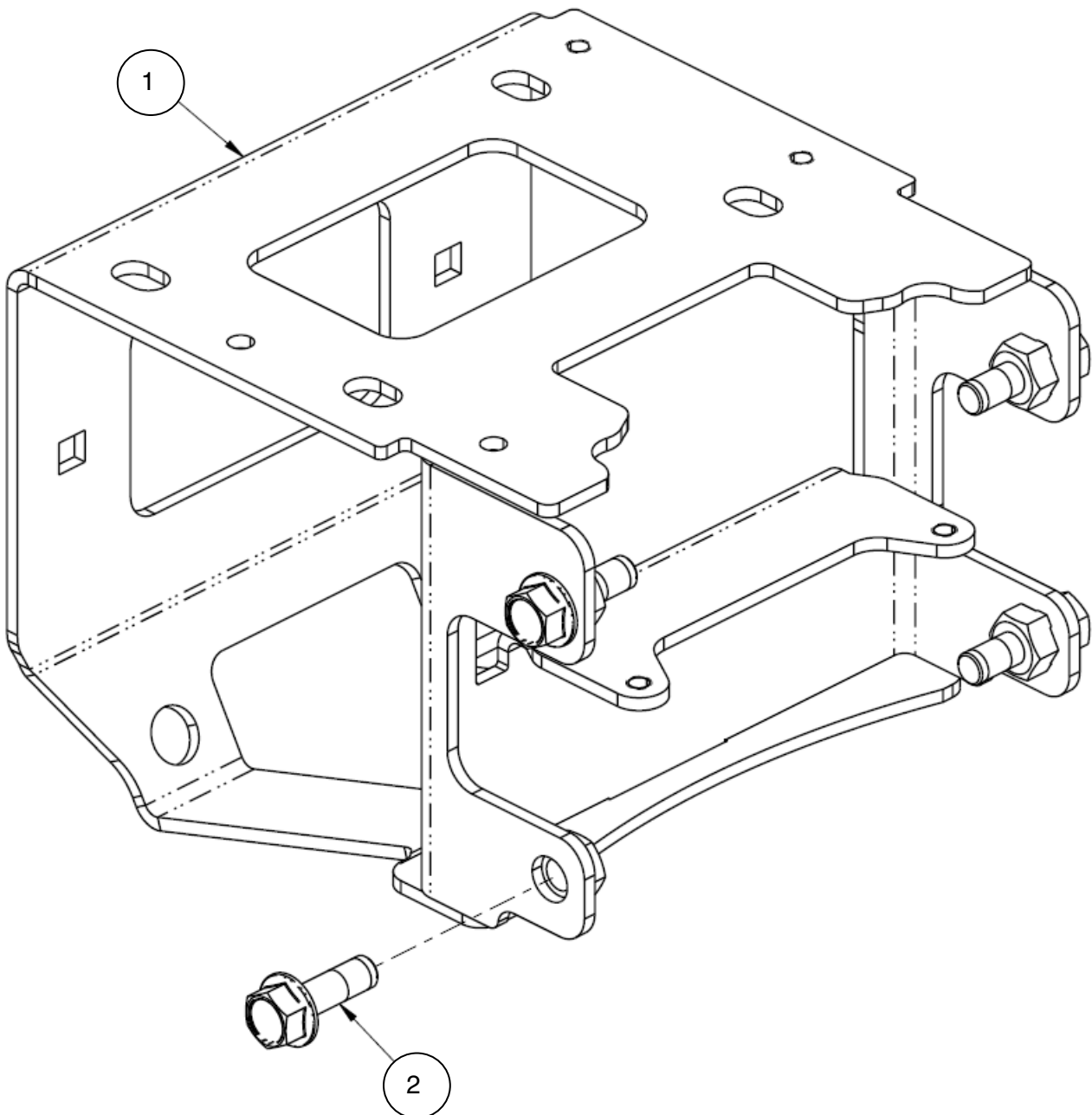

## BEFORE YOU BEGIN:

- Your Kolpin accessory is exclusively designed for your vehicle
- Please read and understand all instructions
- Verify all parts and tools are accounted for
- To ensure a satisfactory installation, follow all steps correctly and in the sequence described
- Keep these instructions for future reference or for informational requests
- To facilitate installation, make sure that your vehicle is clean and free of debris
- All directions referring to right and left are when the rider is sitting on the machine

## TOOLS REQUIRED:

- 13mm Socket
- T27 Torx (Sportsman)
- T40 Torx (ACE)
- Do not use impact tools to install hardware

## APPROXIMATE ASSEMBLY TIME: 15 minutes

Note: If any hardware is missing, do not return to the store. Call us to help, Toll Free 1-877-956-5746.

Installation instructions include vehicle preparation, accessory installation and vehicle reassembly provided for 2021 Sportsman 450/570 models, 2014-2020 Sportsman 450/570 models, 2013-2021 Sportsman 850/1000 models and Polaris ACE models. Proceed with installation procedures that best fit your model.

Mount bracket (item #1) has pre-drilled holes for mounting Kolpin contactor (provided with winch kit) onto top-right side or backside of bracket as shown in images below and to the right.

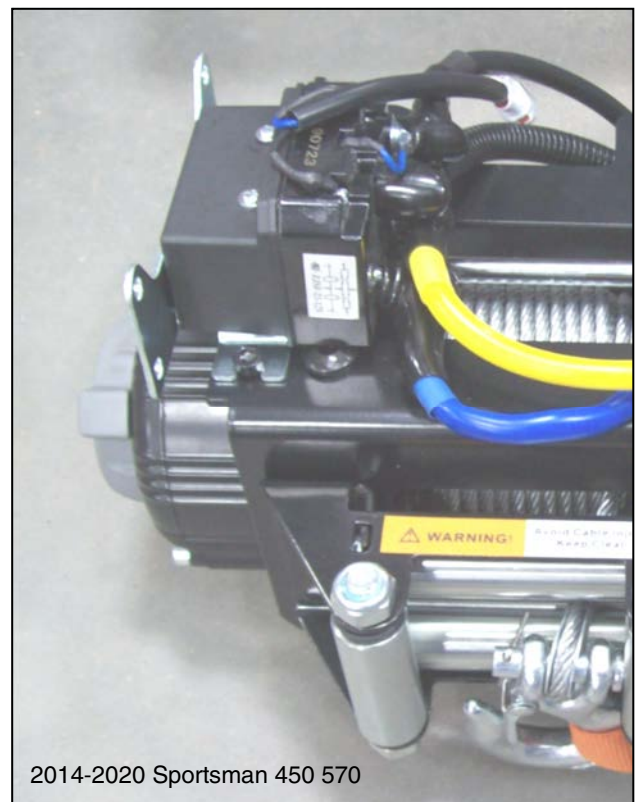

## SPORTSMAN PREPARATION (General):

1. Shift vehicle transmission into "PARK". Turn key to "OFF" position and remove from vehicle.
2. Remove accessory front brush guard from vehicle, if equipped.
3. Detach the rubber latch on both sides and open front rack as shown. (See illustration 1-1).

## 2021 SPORTSMAN 450/570 MODELS:

4. Remove and keep nut from black (negative) battery cable and disconnect negative battery cable. Move boot off red (positive) battery cable. Remove and keep nut from red (positive) battery cable and disconnect positive battery cable. (See illustration 1-2).



### WARNING

**ALWAYS** disconnect black negative (-) cable from battery **FIRST**. Failure to do so will result in high current electrical arc, and may result in battery explosion if tool touches grounded frame. Death or serious injury may occur.

5. Remove and keep four screws from lower front bumper cover as shown. Remove lower front bumper cover. (See illustration 1-3).
6. Remove and discard two push pin rivets from panel on front bumper cover as shown. Remove and discard panel. (See illustration 1-4).

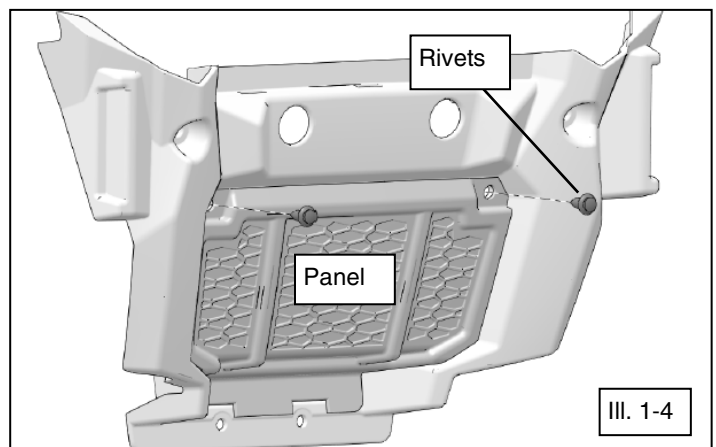
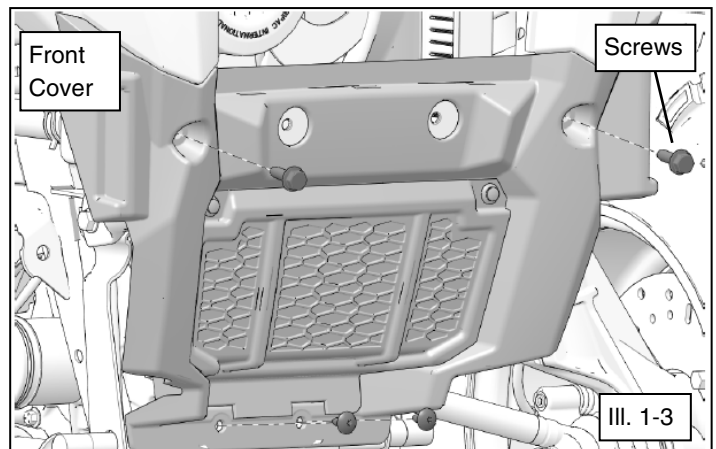
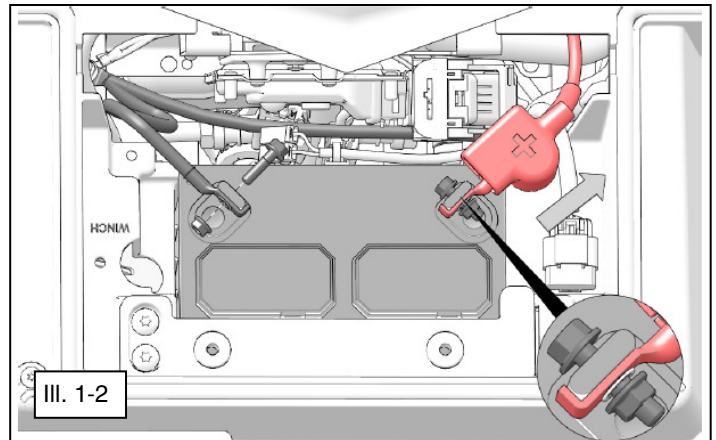
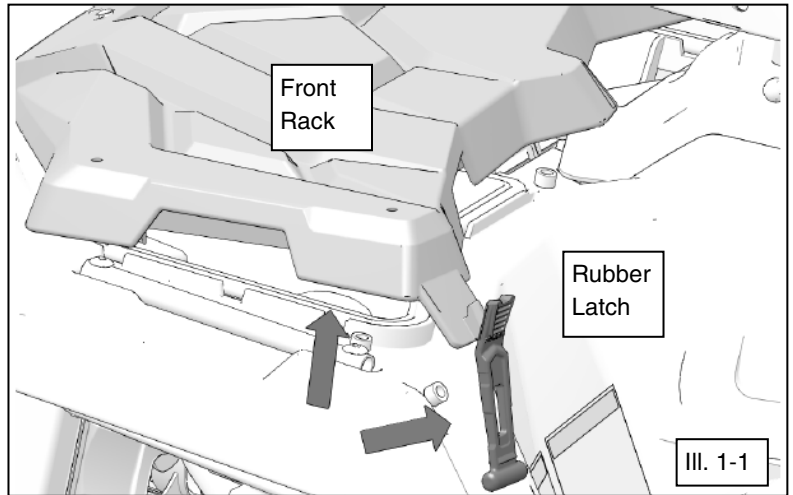

**2014-2020 SPORTSMAN 450/570 MODELS:**

7. Remove and keep rubber seal. (See illustration 1-5).
8. Remove and keep four screws from front cover as shown. (See illustration 1-6).
9. Lift front cover upwards slowly to disengage tabs on cover from slots as shown. (See illustration 1-7).
10. Remove and keep nut from black (negative) battery cable and disconnect negative battery cable. Move boot off red (positive) battery cable. Remove and keep nut from red (positive) battery cable and disconnect positive battery cable. (See illustration 1-8).

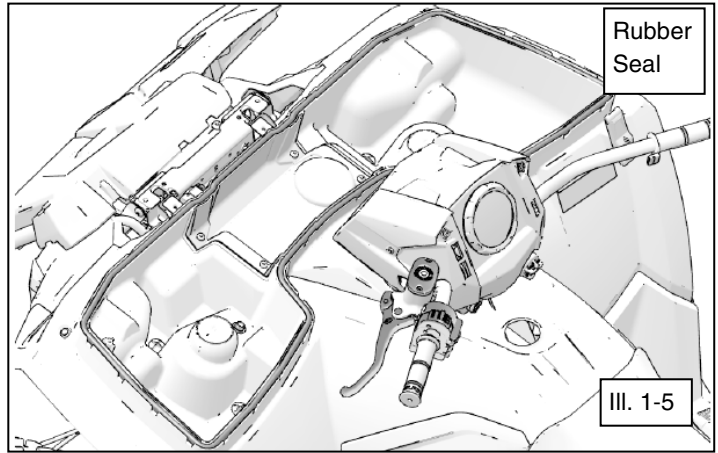

**⚠ WARNING ⚠**

**ALWAYS** disconnect black negative (-) cable from battery **FIRST**. Failure to do so will result in high current electrical arc, and may result in battery explosion if tool touches grounded frame. Death or serious injury may occur.

11. Remove and keep four lower front bumper cover screws. (See illustration 1-9).
12. Remove winch cover from lower front bumper cover. You can keep it removed or trim as marked. (See illustration 1-10).  
**Note, before installing winch kit, add or replace proper fluid to your vehicle's front gear case as required in the service manual. This process will be difficult to do after the winch is installed.**

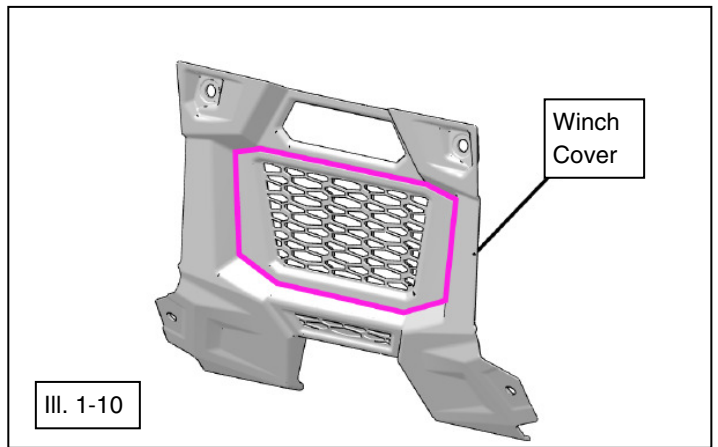
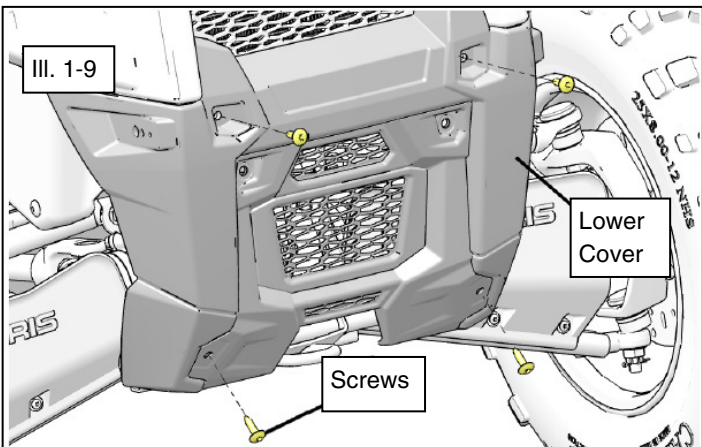
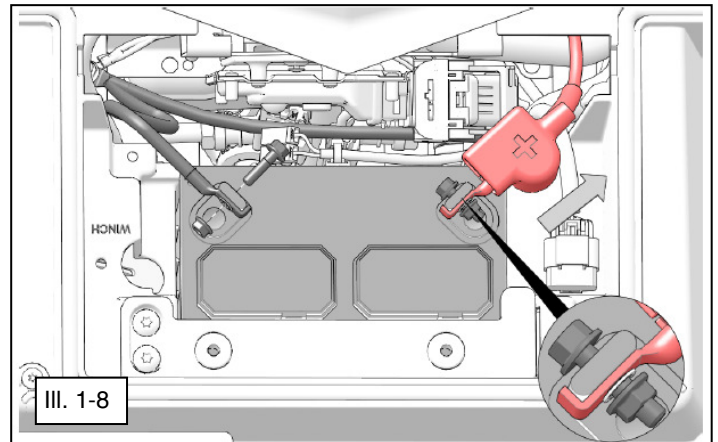
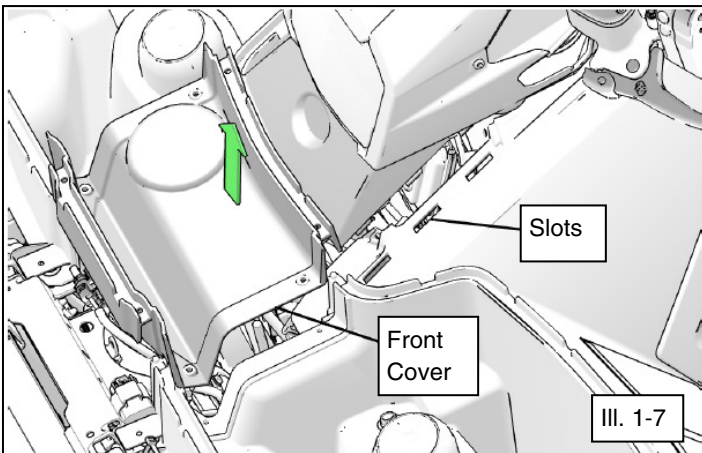
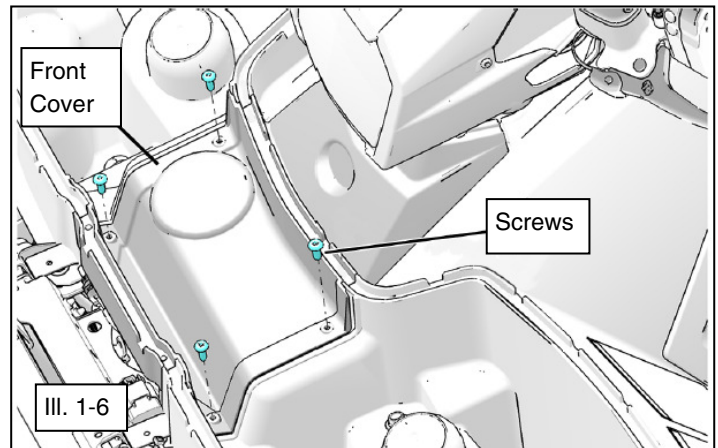

## 2013-2021 SPORTSMAN 850/1000 MODELS:

13. Turn two latches and lift out storage bin. (See illustration 1-11).
14. Fold up ends of battery cover to access battery bolts as shown. (See illustration 1-12).
15. Disconnect black (negative) and red (positive) cables from battery. (See illustration 1-13).



### WARNING

**ALWAYS** disconnect black negative (-) cable from battery **FIRST**. Failure to do so will result in high current electrical arc, and may result in battery explosion if tool touches grounded frame. Death or serious injury may occur.

16. Remove and keep four bolts from lower front bumper cover. (See illustration 1-14).
17. Remove and discard two push pin rivets from winch cover. Remove and discard winch cover as shown. (See illustration 1-15). **Note, before installing winch kit, add or replace proper fluid to your vehicle's front gear case as required in the service manual. This process will be difficult to do after the winch is installed.**

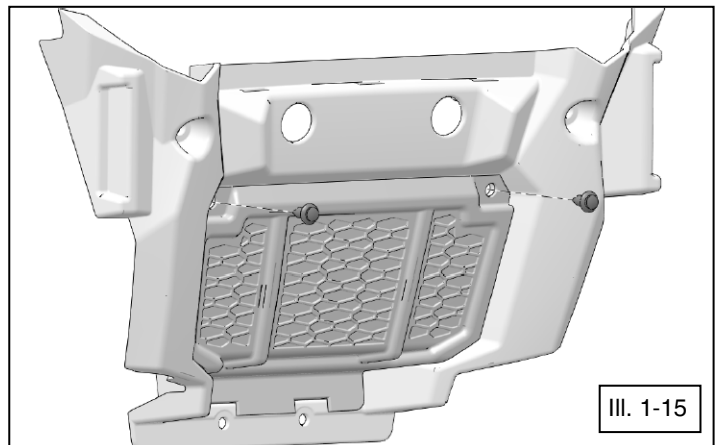
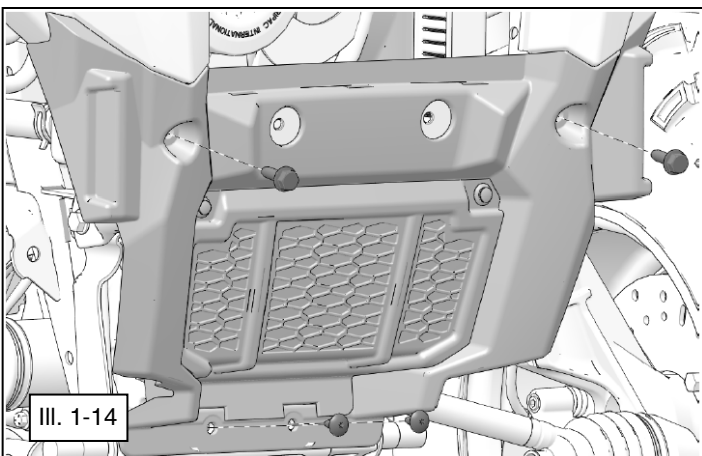
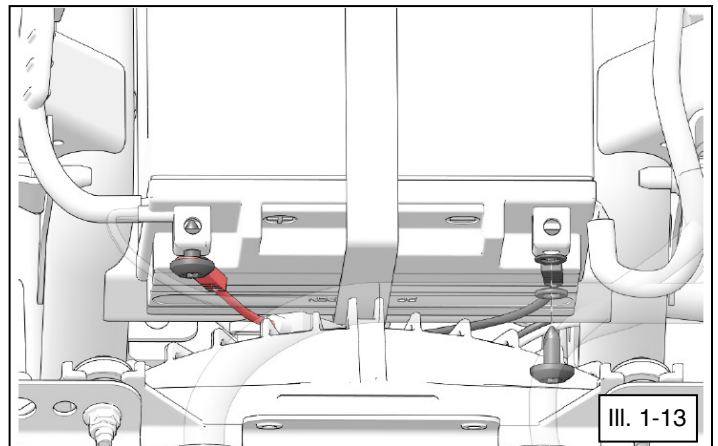
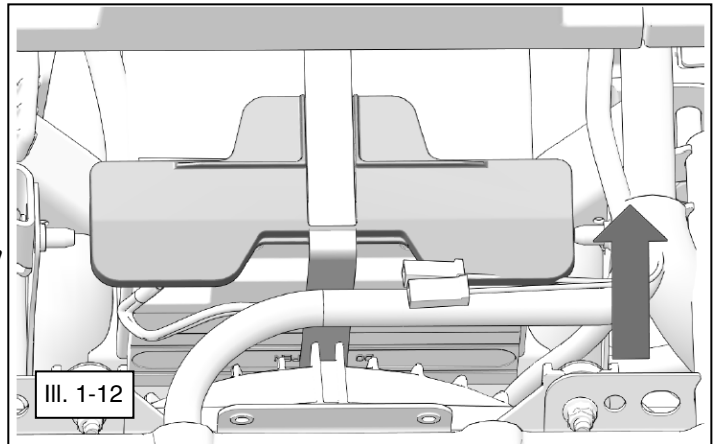
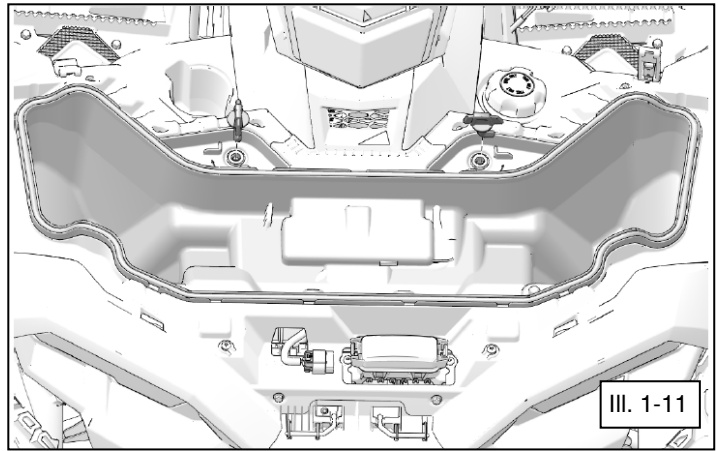

### ACE MODELS:

18. Remove front grille guard from vehicle by removing four bolts as shown. (See illustration 1-16). **Note, OEM hardware will be needed to reinstall front grille guard.**

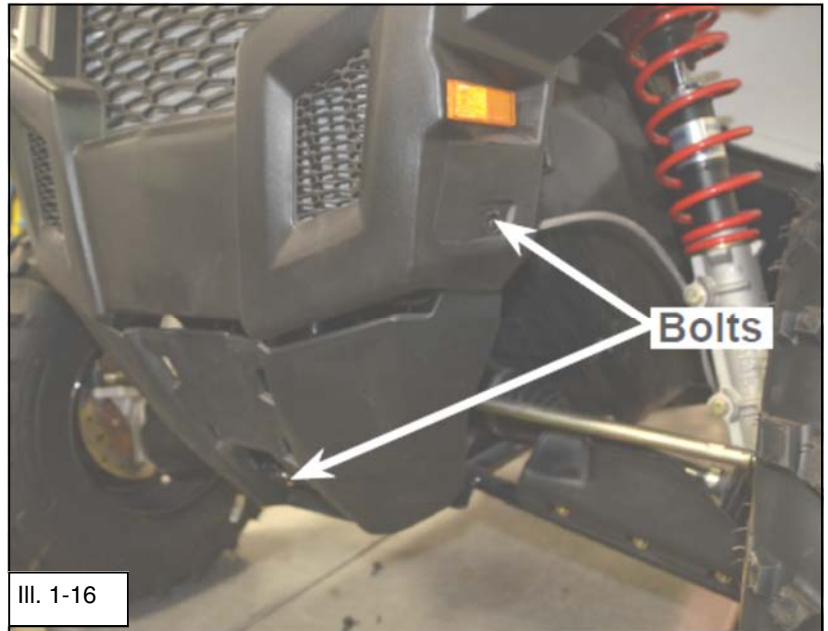

### WINCH ASSEMBLY:

19. Install the roller fairlead and winch to the winch mounting bracket (item #1) as shown. Use the hardware included in the winch kit for this step. Tighten to specification. (See illustrations 1-17 and 1-18).

 = T
<b>8MM FASTENER TORQUE:</b> 17 ft. lbs. (23 Nm)

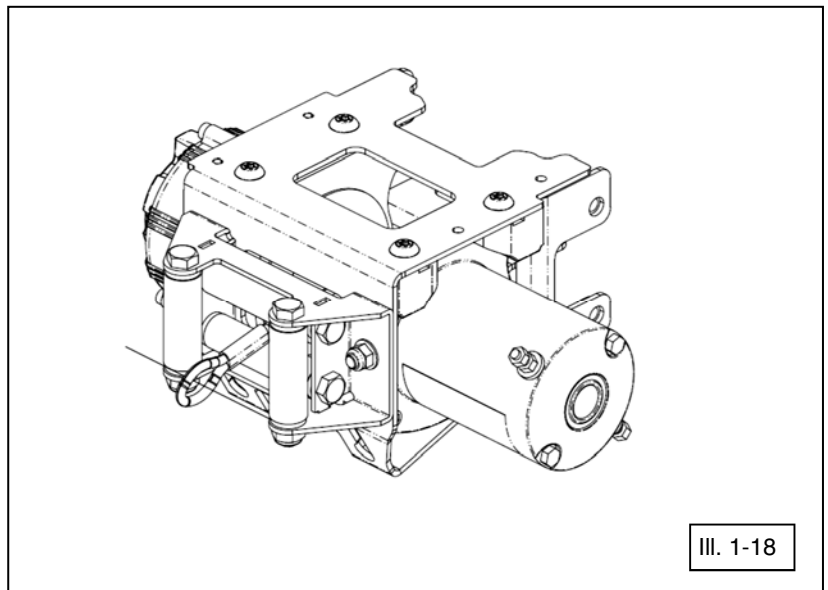
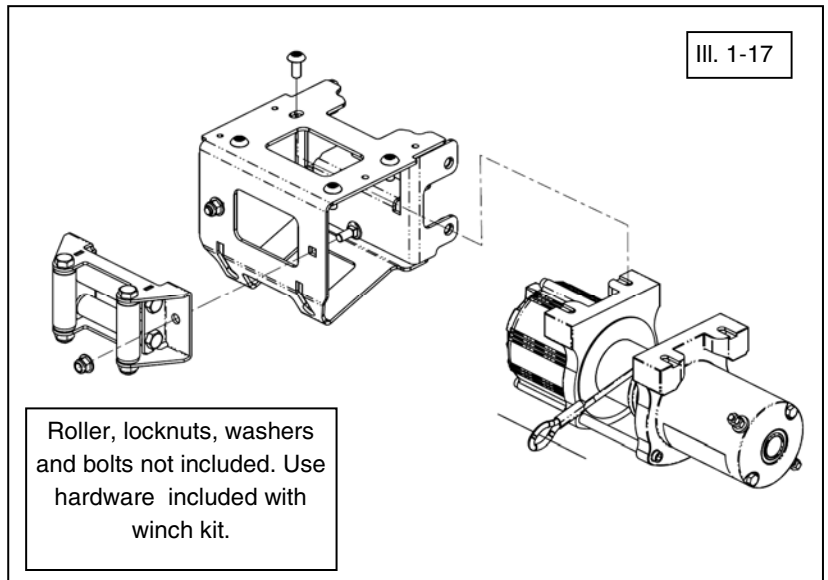



### 2014 SPMN 570 Install Winch to Mount:

20. For 2014 Sportsman 570 models: To gain clearance access for installation of wiring, the winch motor should be located on the left side of the vehicle as shown. The winch motor electric terminal studs will clear the bumper frame. Position the winch inside the winch mount as previously shown in illustrations 1-17 and 1-18. Use hardware supplied with winch kit to secure to bracket. Tighten to specification. (See illustration 1-19).

 = T
<b>8MM FASTENER TORQUE:</b> 17 ft. lbs. (23 Nm)

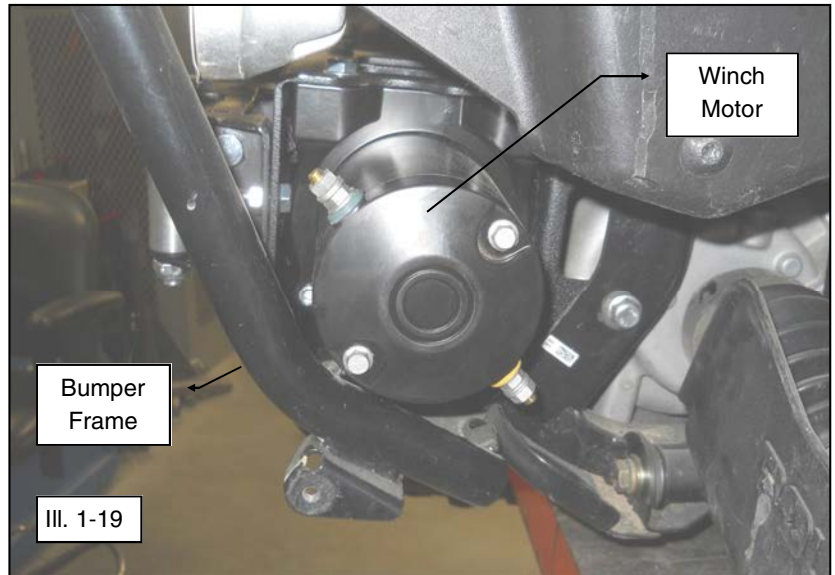

### 2015-2020 SPMN 450/570 Install Winch to Mount:

21. For 2015 - 2020 Sportsman 450/570 models: To gain clearance access for installation of wiring, the winch motor should be located on the left side of the vehicle as shown. The winch motor electric terminal studs will clear the bumper frame. Position the winch inside the winch mount as previously shown in illustrations 1-17 and 1-18. Use hardware supplied with winch to fasten to bracket. Tighten to specification. (See illustrations 1-20 and 1-21).

 = T
<b>8MM FASTENER TORQUE:</b> 17 ft. lbs. (23 Nm)

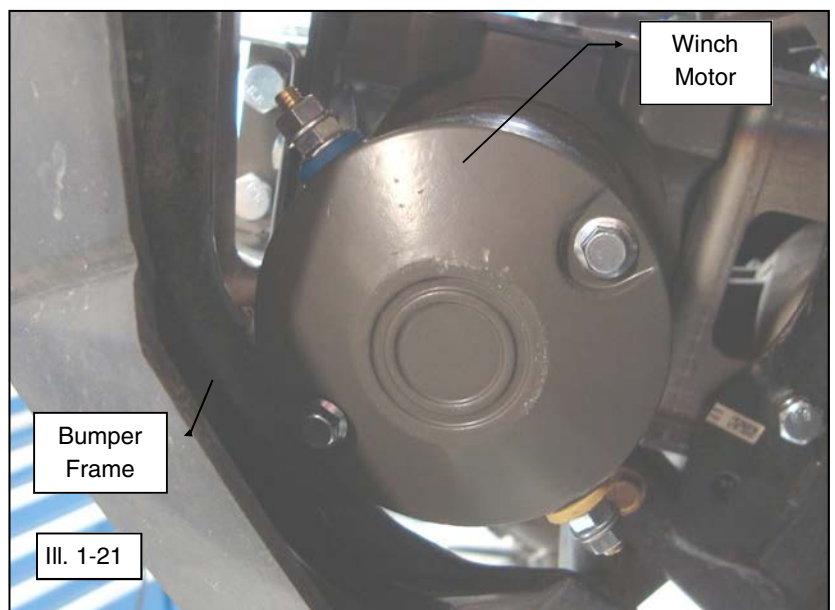
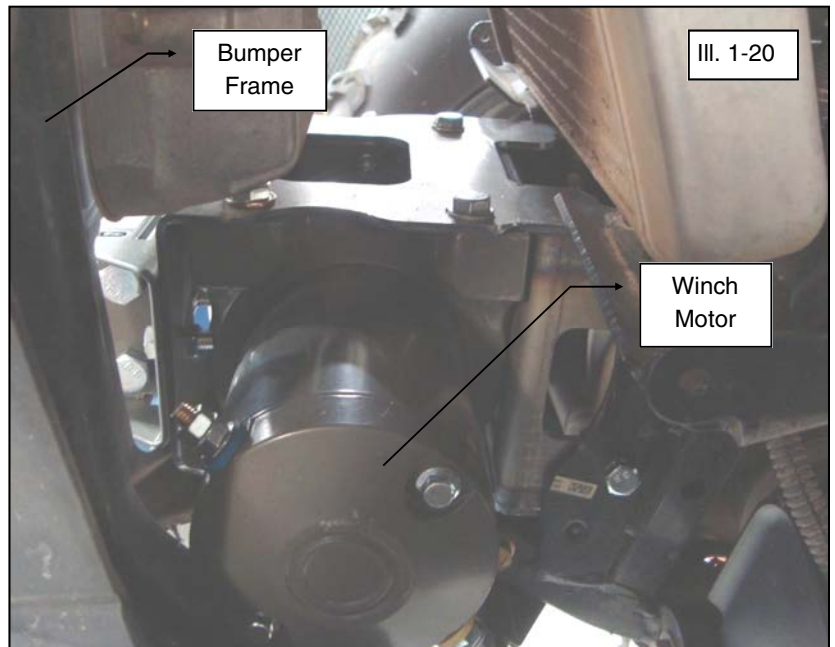

### Winch Cable Wrap on Spool Drum:

22. The winch cable or rope should be wrapped around spool drum as shown. Spooling the cable as shown will prolong cable life and enhance winch performance. (See illustration 1-22).

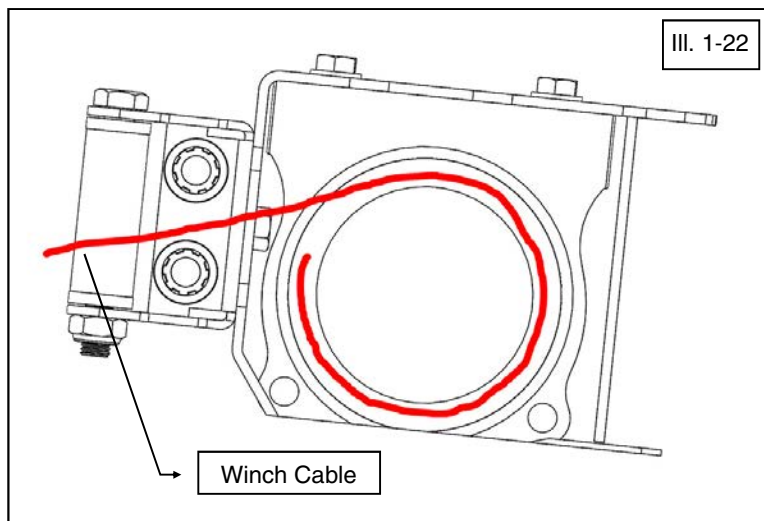

### WINCH ACCESSORY INSTALLATION:

23. Install the winch mount assembly into the vehicle as shown. Use the screws (item #2) included in the mount kit for this step. Tighten to specification. (See illustration 1-23).

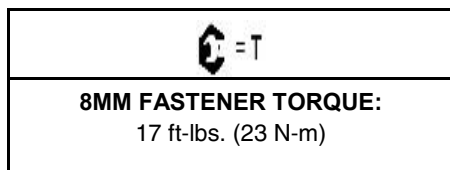

24. On models with strut front suspension, use front set of holes for mounting winch.
25. Connect the hook to cable or rope by using hardware included in winch kit.

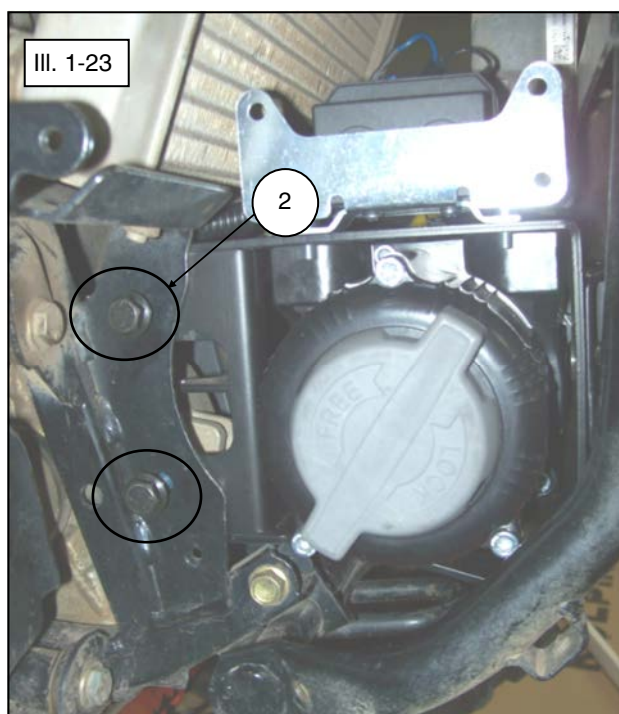

## SPORTSMAN REASSEMBLY (General):

- Using the winch kit instructions, route and connect the electrical cables and components for the winch system.
- Make sure there are no exposed wires or terminals. Tightly bind all loose wires and attach away from moving parts and heat sources.

### **WARNING**

When **BOTH** battery cables are disconnected **ALWAYS** connect **AND** tighten red positive (+) battery cable **FIRST**. Failure to comply will result in high current electrical arc that may result in battery explosion, if tool touches grounded frame. Death or serious injury may occur.

## 2021 SPORTSMAN 450/570 MODELS:

- Connect all red (positive) wires to the positive battery terminal. Connect all black (negative) wires to the negative battery terminal. Tighten to specification. (See illustration 1-24). **Note, put the winch wire through the opening in the electrical boot that covers the main vehicle power wire.**



**BATTERY BOLT TORQUE:**  
60 in.-lbs. (6 N-m)

- Put front bumper cover onto vehicle and identify area to be trimmed on both sides of bumper cover. (See illustration 1-25).
- Cut along marked lines.
- Install front bumper cover with four fasteners. Tighten until fully seated. (See illustration 1-26).
- Close front rack and attach two rubber latches.
- Install accessory front brush guard, if equipped.
- With key in ON position, test winch for proper operation.

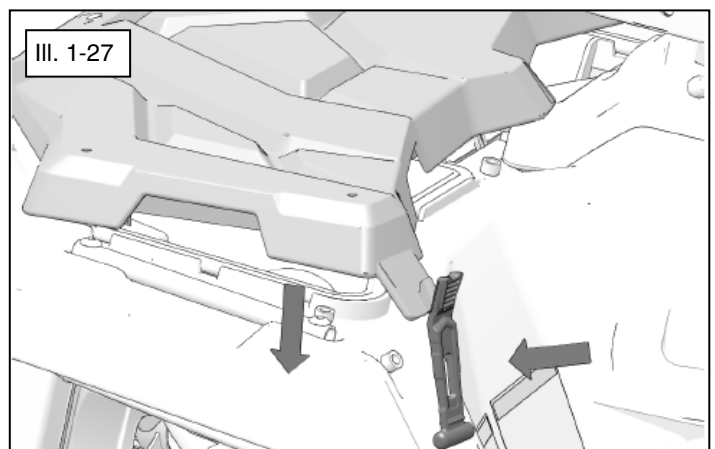
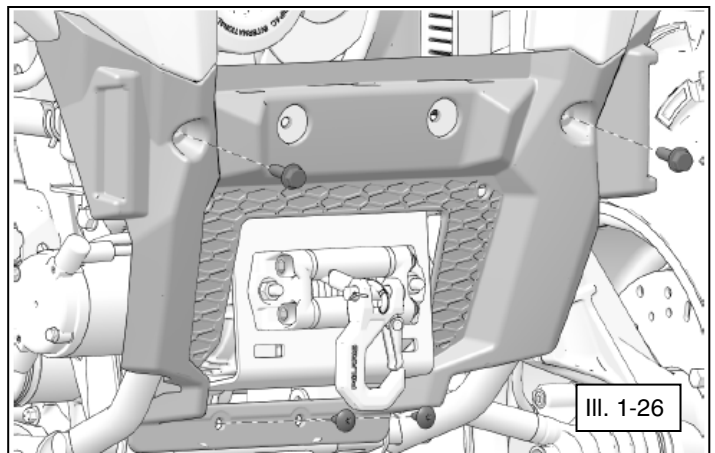
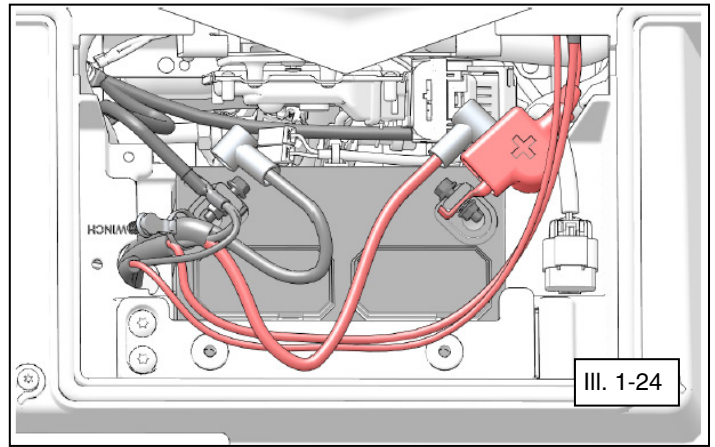

## 2014-2020 SPORTSMAN 450/570 MODELS:

35. If you do not plan to use a plow, reinstall winch cover.
36. Install front bumper cover with four fasteners. Tighten until fully seated. (See illustration 1-28).
37. Connect all red positive wires to the positive battery terminal. Connect all black negative wires to the negative battery terminal. Torque to specification.

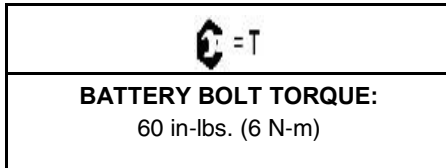

38. Lower front cover down slowly to engage tabs on cover into slots. (See illustration 1-29).
39. Install four screws to front cover. Tighten until fully seated. (See illustration 1-30).
40. Install rubber seal. (See illustration 1-31).
41. Close front rack and attach two rubber latches. (See illustration 1-32).
42. Install accessory front brush guard, if equipped.
43. With vehicle key in ON position, test winch for proper operation.

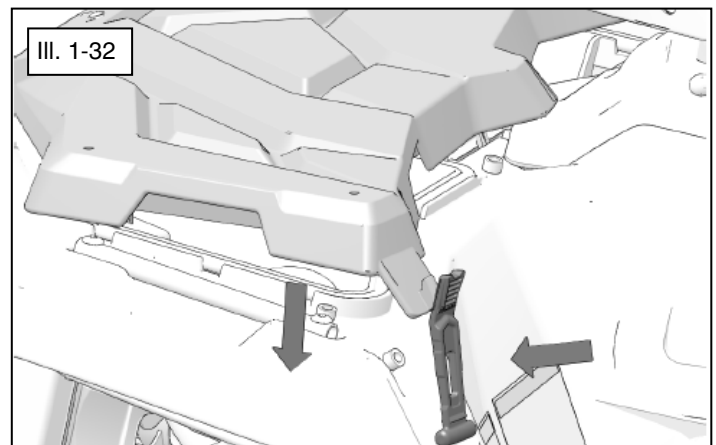
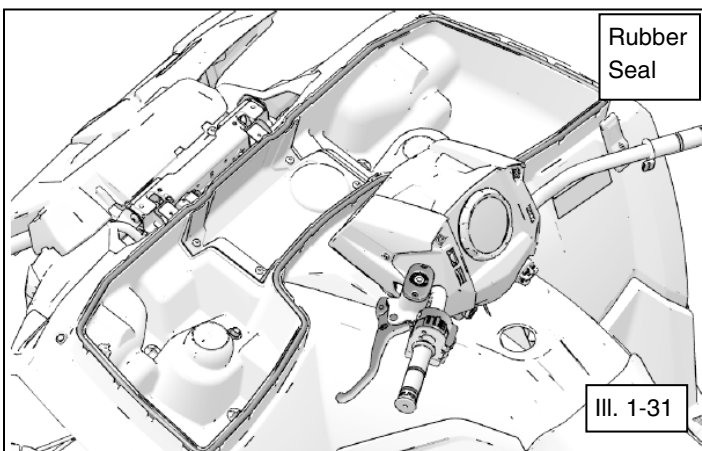
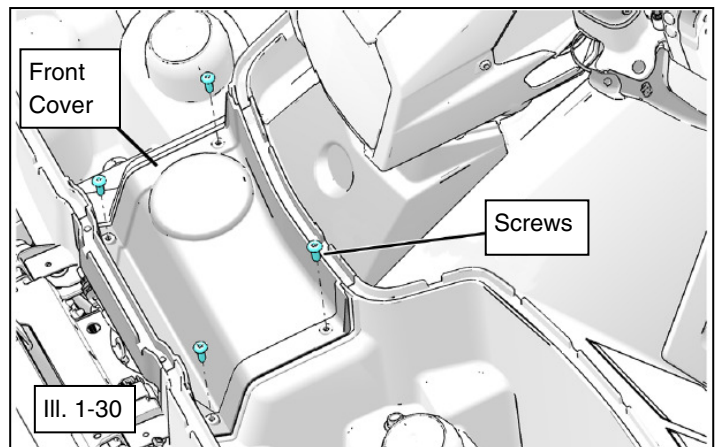
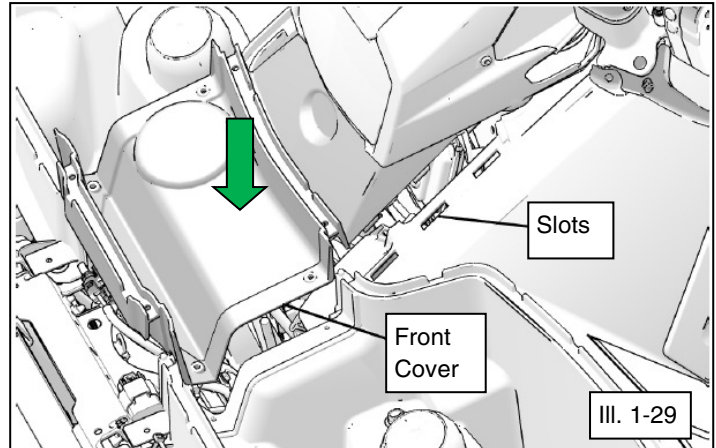
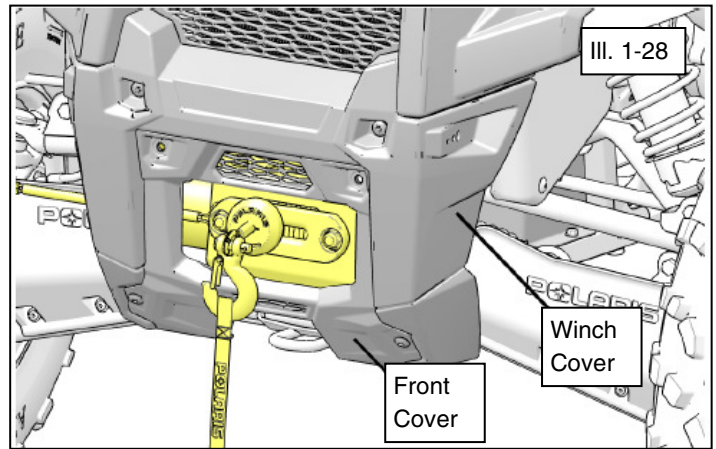

## 2013-2021 SPORTSMAN 850/1000 MODELS:

44. Connect all red positive wires to the positive battery terminal. Connect all black negative wires to the negative battery terminal. Torque to specification. (See illustration 1-33).

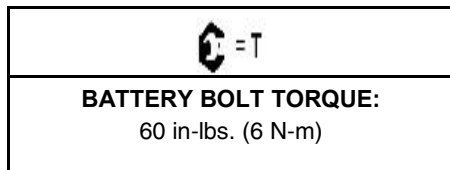

45. Install front storage bin and attach two fasteners. (See illustration 1-34).
46. Install front bumper cover with four fasteners. Tighten until fully seated. (See illustration 1-35).
47. Close front rack and attach two rubber latches. (See illustration 1-32).
48. Install accessory front brush guard, if equipped.
49. With vehicle key in ON position, test winch for proper operation.

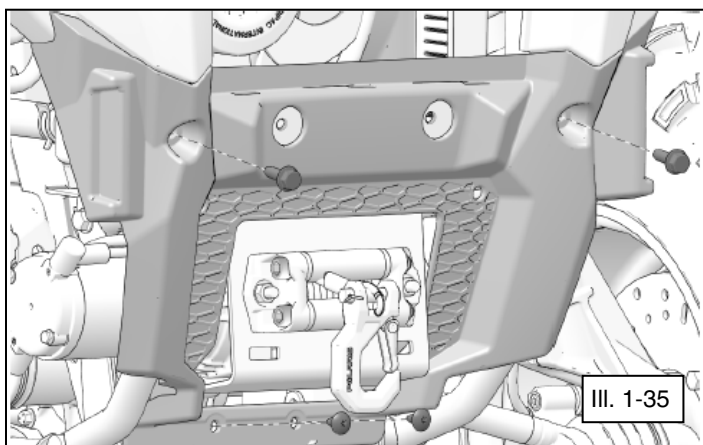
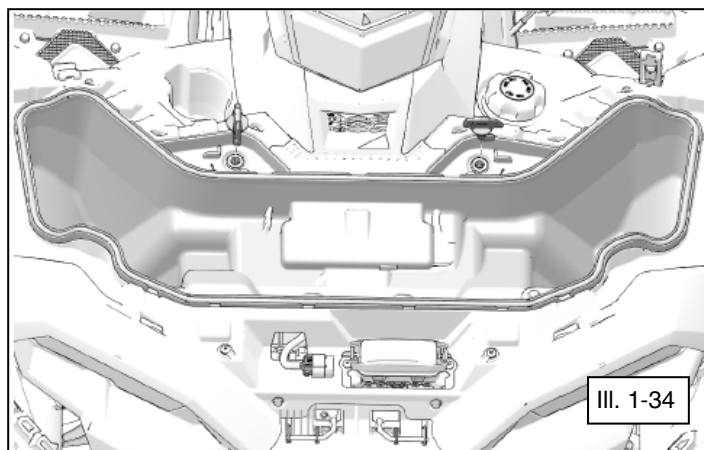
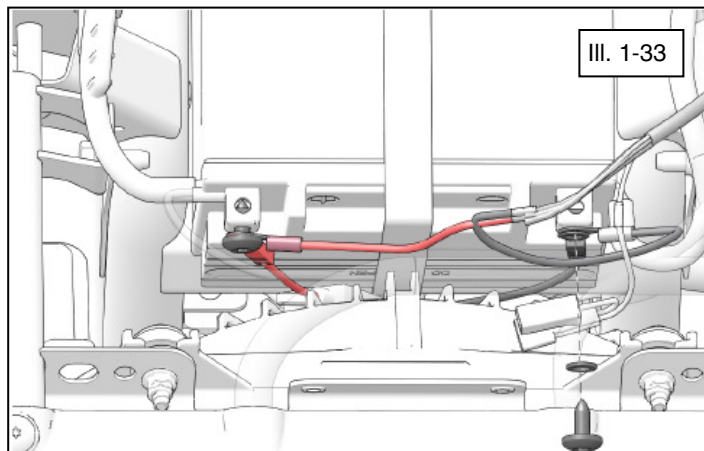

## ACE Models Reassembly:

50. Reinstall lower OEM hardware in the locations (C) shown on each side of vehicle. (See illustration 1-36).  
**Note, front grille lower guard will not be reinstalled.**

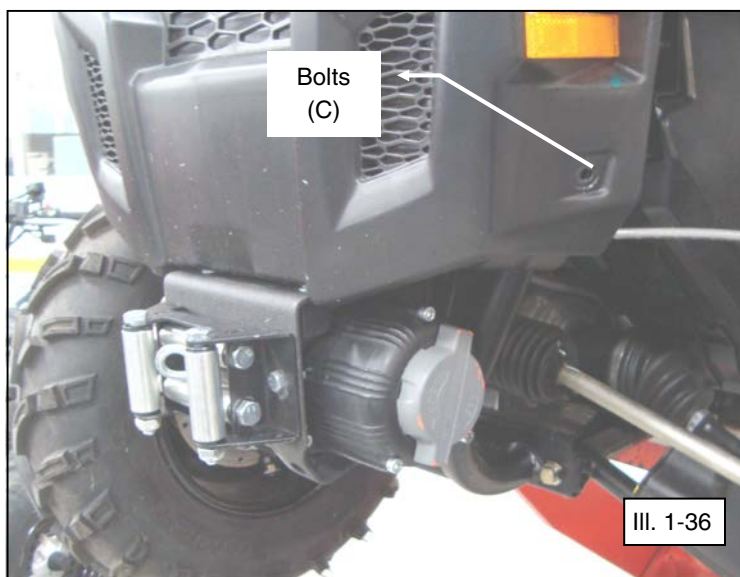



## One Year Limited Warranty

For the period of one (1) year from the purchase date, Kolpin will replace for the original purchaser, free of charge, any part or parts found upon examination by Kolpin to be defective in material, workmanship, or both.

All transportation costs incurred submitting product to Kolpin for warranty consideration must be borne by the purchaser. If Kolpin determines that the product must be returned to the factory for credit, please call 1-877-956-5746 for a Return Merchandise Authorization (RMA) number and shipping instructions.

This warranty does not apply to parts that have been damaged by accident, alteration, abuse, improper maintenance, normal wear, or other causes beyond the manufacturer's control. In order to protect you and your ATV, certain parts of the plow system and/or hardware are designed to fail when the equipment is over-stressed. Parts that are lost due to loosening and improper maintenance are not covered under warranty. This warranty does not cover removal or reinstallation labor fees of the plow system and related components.

Peripheral products such as engines, electric motors, and actuators may carry an original manufacturer's warranty. Most hardware is general in nature and is easily obtained locally. Be sure to replace with minimum metric class 8.8 specification.

**Kolpin Outdoors, Inc.**

**Telephone: (763)-478-5800**

**Toll Free: (877)-956-5746**

**Fax Number: (800)-245-7569**

**[www.kolpin.com](http://www.kolpin.com)**

**Email: [customerservice@kolpin.com](mailto:customerservice@kolpin.com)**