

Polaris RZR XP 1000 - Full Vented Windshield



Product Instructions | Part No: 2791

Application: Verify accessory fitment at Kolpin.com.

Before You Begin: Read these instructions and check to be sure all parts are accounted for. If any items are missing, do not return to the store. Call us at 1-877-956-5746 for assistance. Please retain these instructions for future reference and parts ordering information.

Dealers: Provide Instruction Manual to customer at time of purchase.

Tools Required: 4mm Hex Wrench (or Socket) and Torque Wrench

Product Contents:

Item	Description	Qty	Part Number
1	Windshield Panel	1	
2	Shield	2	K100442 (Qty 2)
3	Vent Sub-Assembly	2	
4	Tapping Screw	18	
5	A-Pillar P-Clamp	4	K100448 (Qty 2)
6	Button Head Screw - M6 x 26mm	4	
7	Lock Washer - M6	4	
8	Domed Shoulder Washer - M6	4	
9	Flanged Nyloc Locknut - M6	4	
10	1/4" Edge Seal - 87.3"	1	K100460 (Qty 1)
11	1/4" Edge Seal - 20.5"	1	
12	1/4" Edge Seal - 4"	2	

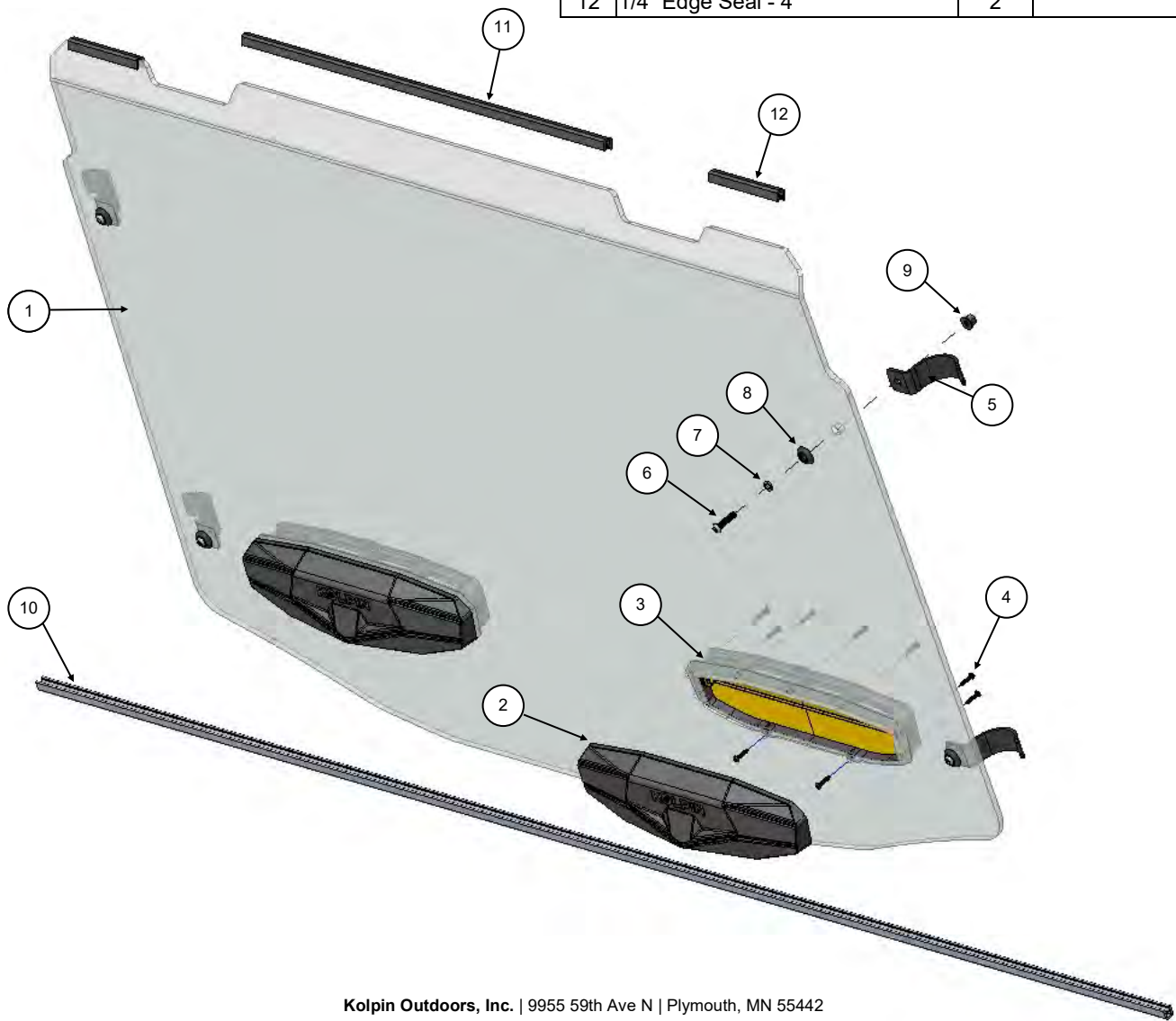

Kolpin Outdoors, Inc. | 9955 59th Ave N | Plymouth, MN 55442

(877) 956-5746 or (763) 478-5800 | www.kolpin.com | customerservice@kolpin.com

Assembly Time: Approximately 30 minutes

Important: This product is exclusively designed for your vehicle. Please read the installation instructions thoroughly before beginning. Installation is easier if the vehicle is clean and free of debris. For your safety, and to ensure a satisfactory installation, perform all installation steps correctly in the sequence shown. Keep hands clean and free of grease and dirt when handling glass and plastic products.

Installation Instructions:

1. Shift vehicle transmission into PARK. Turn key to OFF position and remove from vehicle.
2. Carefully remove the Windshield panel from the box and place on a clean flat surface that won't scratch the Windshield. We recommend leaving the protective film on both sides of the Windshield panel during assembly and only partially peeling it back in locations where mounting components are attached.
3. Peel away the film around the vent mounting areas and install the Vents. Refer to the Poly Windshield Vent Kit manual to install the Vents. See Illustration 1-1.
4. Peel away the film around the entire edge or perimeter of the Windshield and install the Edge seals (items 10, 11, and 12). See Illustration 1-2.
5. Remove the protective film completely and place Windshield onto front cab frame and adjust the Windshield to the most centered position. Install all four P-clamps (item 5) by using fastener items 6, 7, 8 and 9. Leave snug. See Illustration 1-3 and page 1 for hardware orientation.
6. Ensure that the Windshield remains in most centered position then torque all P-clamps fasteners to 7 ft lbs.

 = T
SPECIFIED FASTENER TORQUE: 7 ft. lbs. (84 in-lb) (9.5 Nm)

7. Re-inspect hardware before and after riding or trailering.

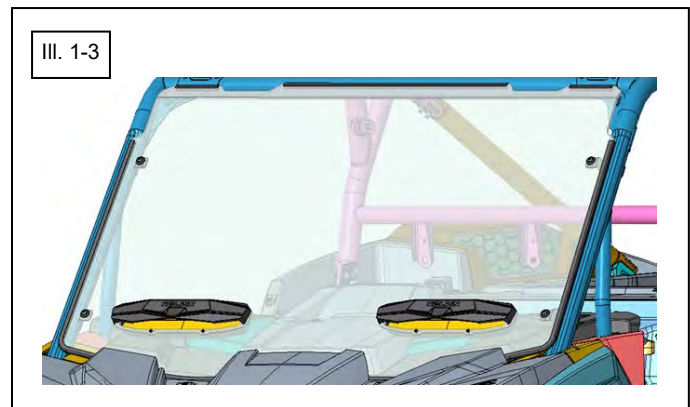
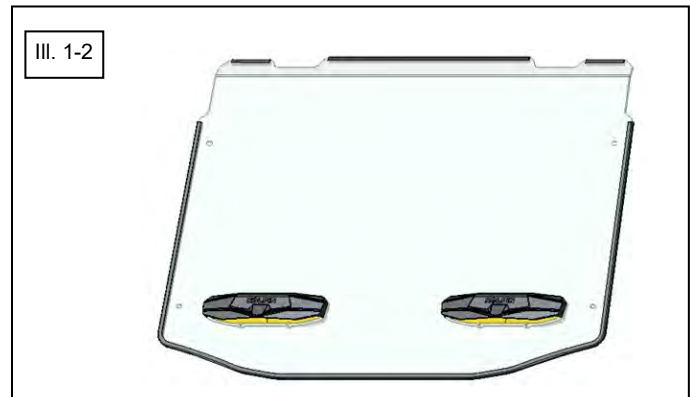
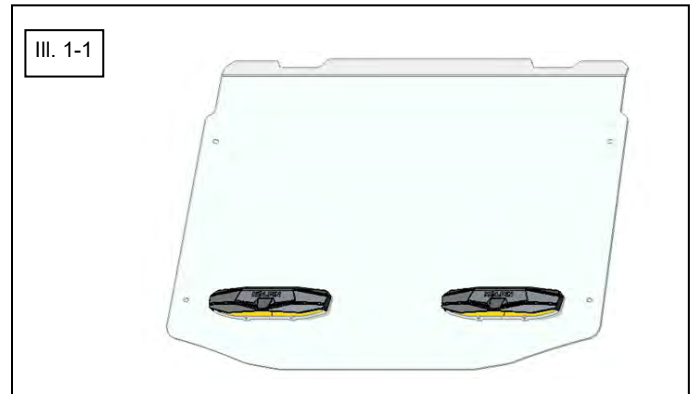



DANGER



TO AVOID SERIOUS INJURY OR DEATH:

1. DO NOT TRAILER VEHICLE FACING REARWARD WITH WINDSHIELD INSTALLED. AIRFLOW MAY CAUSE WINDSHIELD TO SEPARATE FROM VEHICLE, RESULTING IN AN ACCIDENT AND SEVERE INJURY OR DEATH. REMOVE WINDSHIELD OR TRANSPORT VEHICLE IN ENCLOSED TRAILER.
2. UTVs ARE TO ONLY BE DRIVEN WITH CLEAN WINDSHIELDS FOR DRIVING VISIBILITY. IF DIRT OR DEBRIS ACCUMULATES ON THE WINDSHIELD WHEN RIDING, STOP THE UTV AT THE NEXT SAFE LOCATION ON THE TRAIL TO CLEAR OFF THE WINDSHIELD BEFORE YOU RESUME RIDING.
3. ONLY INSTALL WINDSHIELDS THAT ARE DESIGNED FOR THE MAKE AND MODEL OF THE UTV. INSTALLATION OF A WINDSHIELD THAT WAS NOT DESIGNED FOR THE UTV MAKE AND MODEL CAN IMPACT WINDSHIELD DURABILITY AND PERFORMANCE.
4. READ AND UNDERSTAND WINDSHIELD INSTRUCTION SHEETS AND UTV OWNER MANUAL BEFORE WINDSHIELD INSTALLATION OR OPERATING THE VEHICLE.
5. PERIODICALLY CHECK FOR WEAR AND TIGHTNESS OF ALL FASTENERS. ALWAYS INSPECT BEFORE AND AFTER RIDING OR TRAILERING. REPLACE OR RE-TORQUE FASTENERS AS NECESSARY.

Windshield Cleaning Information:

- Remove all dirt, mud, dust and debris from Windshield with water before cleaning.
- Use a mild soap or dishwashing detergent along with a soft sponge or soft cotton cloth to clean Windshield surface. Do not apply in direct sunlight. Rinse with water immediately and dry with a soft cotton cloth or chamois.
- Always test cleaning agents in a small inconspicuous area prior to cleaning entire panel.
- Never use Windshield cleaning fluids (409, Windex, etc.), gasoline, high alkaline cleaners, or solvents.
- Never use abrasives, brushes, razor blades, scrapers, squeegees, gloves or dirty cloths.

For additional assistance, please contact Kolpin customer service department at (877) 956-5746 or (763) 478-5800 or email customerservice@kolpin.com.

One Year Limited Warranty

For the period of one (1) year from the purchase date, Kolpin will replace for the original purchaser, free of charge, any part or parts found upon examination by Kolpin to be defective in material, workmanship, or both.

All transportation costs incurred submitting product to Kolpin for warranty consideration must be borne by the purchaser. If Kolpin determines that the product must be returned to the factory for credit, please call 1-877-956-5746 for a Return Merchandise Authorization (RMA) number and shipping instructions.

This warranty does not apply to parts that have been damaged by accident, alteration, abuse, improper maintenance, normal wear, or other causes beyond the manufacturer's control. In order to protect you and your ATV, certain parts of the accessory system and/or hardware are designed to fail when the equipment is over-stressed. Parts that are lost due to loosening and improper maintenance are not covered under warranty. This warranty does not cover removal or reinstallation labor fees of the plow system and related components.

Peripheral products such as engines, electric motors, and actuators may carry an original manufacturer's warranty. Most hardware is general in nature and is easily obtained locally. Be sure to replace with minimum metric class 8.8 specification.