

Polaris Ranger Crew XP 1000 Rear Upper Soft Doors



Product Instructions | Part No: 32510

Application: Polaris Ranger Crew XP 1000 / Ranger Crew 1000, verify accessory fitment at Kolpin.com.

Before You Begin: Read these instructions and check to be sure all parts and tools are accounted for. Please retain these installation instructions for future reference and parts ordering information.

Note: *If any hardware is missing, do not return to the store. Call us to help, Toll Free 1-877-956-5746.*

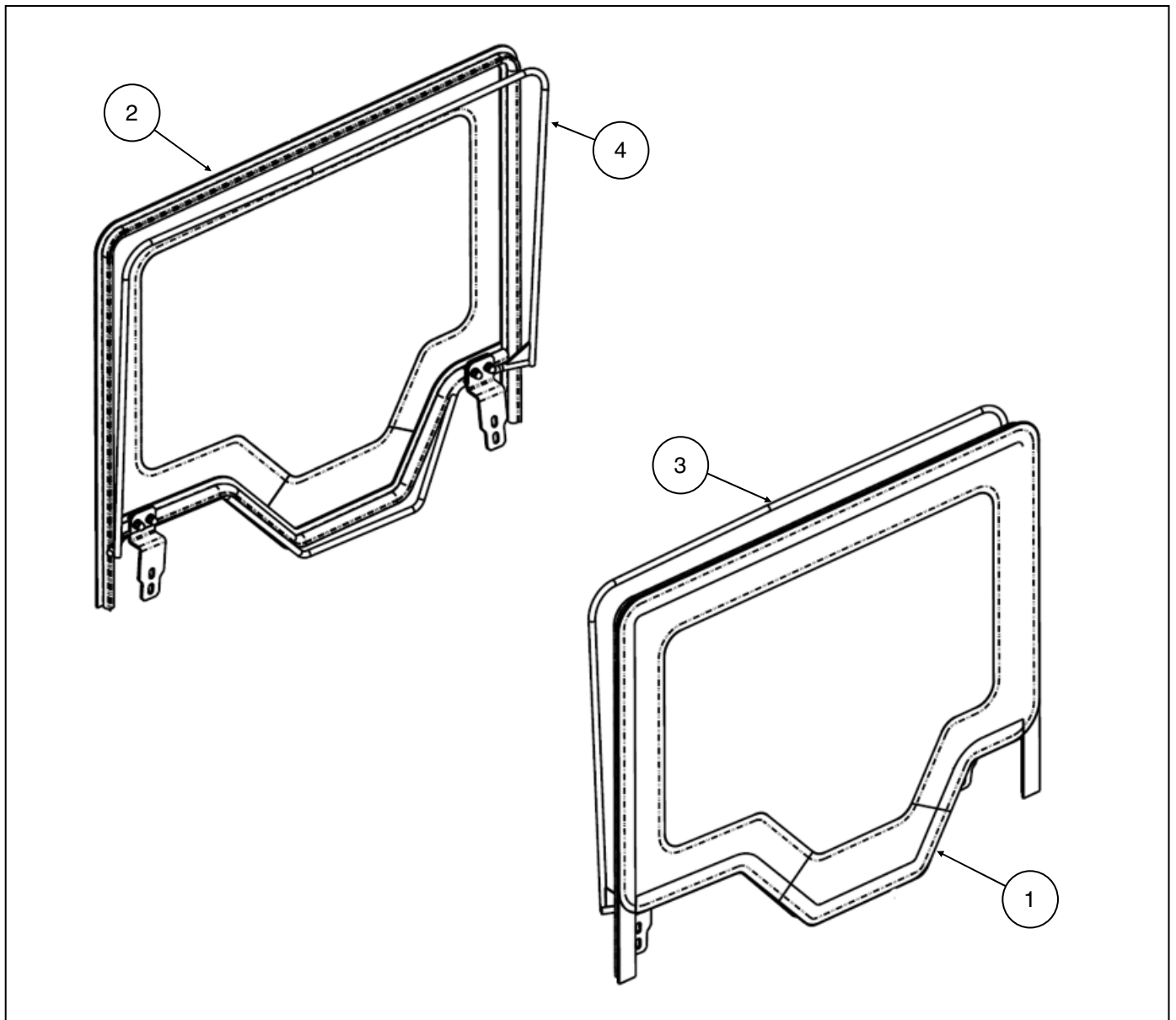

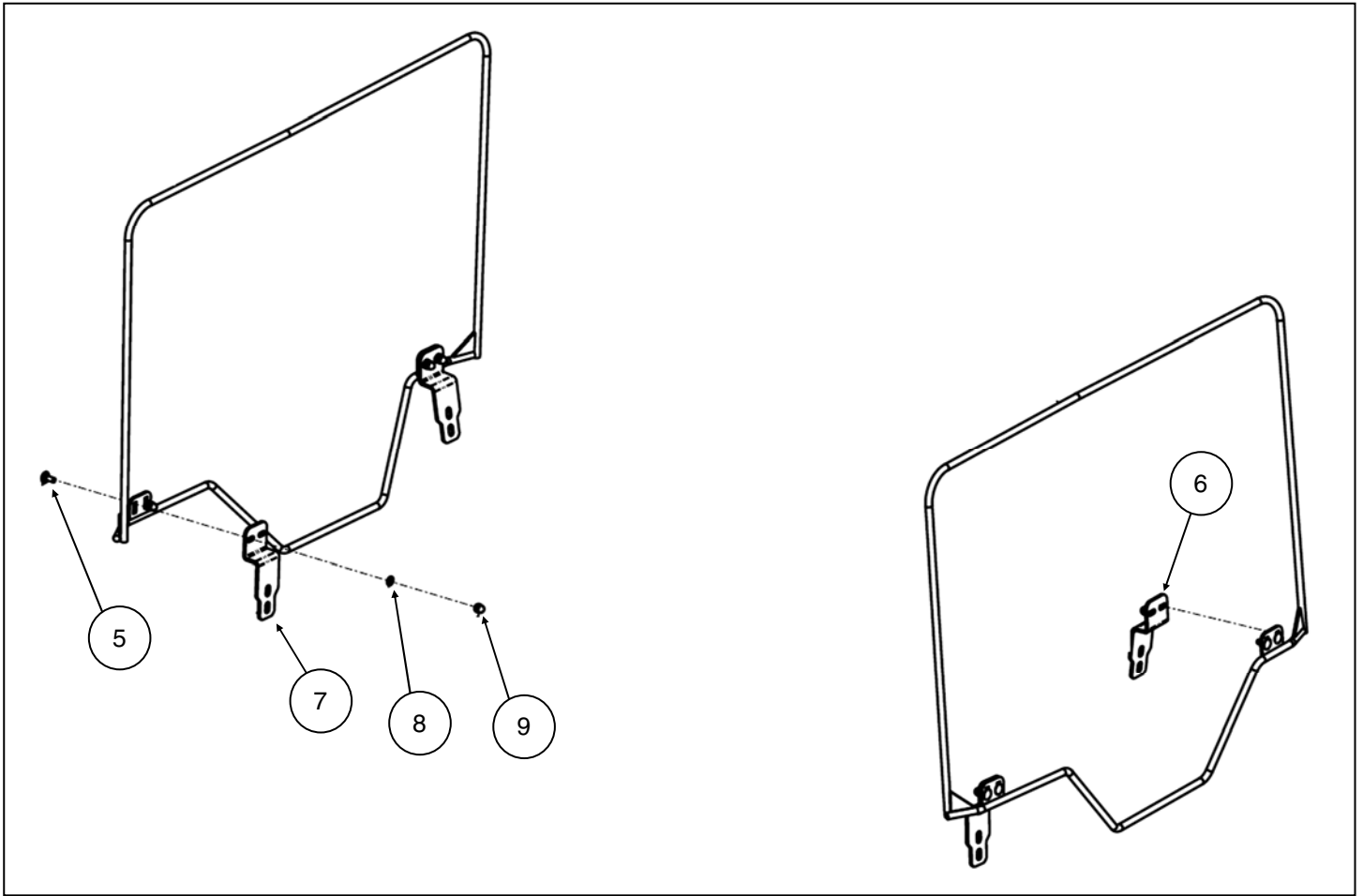

This Kit includes:

Item	Qty	Part Description	Part Number
1	1	LH Ranger Crew Upper Door Skin	32510-CP03
2	1	RH Ranger Crew Upper Door Skin	32510-CP04
3	1	LH Ranger Crew Upper Door Frame	-
4	1	RH Ranger Crew Upper Door Frame	-
5	8	Carriage Screw, Zinc Plated, M6 x 1.0 - 16mm LG	7520194
6	2	Rear Mounting Bracket	32511
7	2	Front Mounting Bracket	32511
8	8	Split Lock Washer, Zinc Plated, 1/4"	7552801
9	8	Acorn Nut, Zinc Plated, M6 x 1.0	7547115

Tools Required:

- Safety Glasses
- Socket Set, Torx Bit
- Socket Set, Metric
- Torque Wrench
- Wrench Set, Metric

Assembly Time: Approximately 24 minutes

Note: The 32510 kit comes mostly assembled from the factory. Some assembly is required.

Important: Your Kolpin Ranger Crew XP 1000 Rear Upper Soft Door Kit is exclusively designed for your vehicle. Please read the installation instructions thoroughly before beginning. Installation is easier if the vehicle is clean and free of debris. For your safety, and to ensure a satisfactory installation, perform all installation steps correctly in the sequence shown. Additional time may be required to accommodate other installed accessories. For better cab assembly procedure, install kits in the following order: rear panel, rear windshield, roof, rear lower half door, and rear upper soft door.

NOTICE

Kolpin recommends two people install this kit.

RANGER PREPARATION:

1. Shift vehicle transmission into "PARK". Turn ignition key to "OFF" position and remove from vehicle ignition.
2. Remove the four upper T40 Torx drive head screws from the LH rear lower door frame as shown. (See illustration 1-1). **Note, the screws removed from lower door will be used to install the upper soft door.**
3. Remove the LH UPPER RANGER door assembly from the packaging.

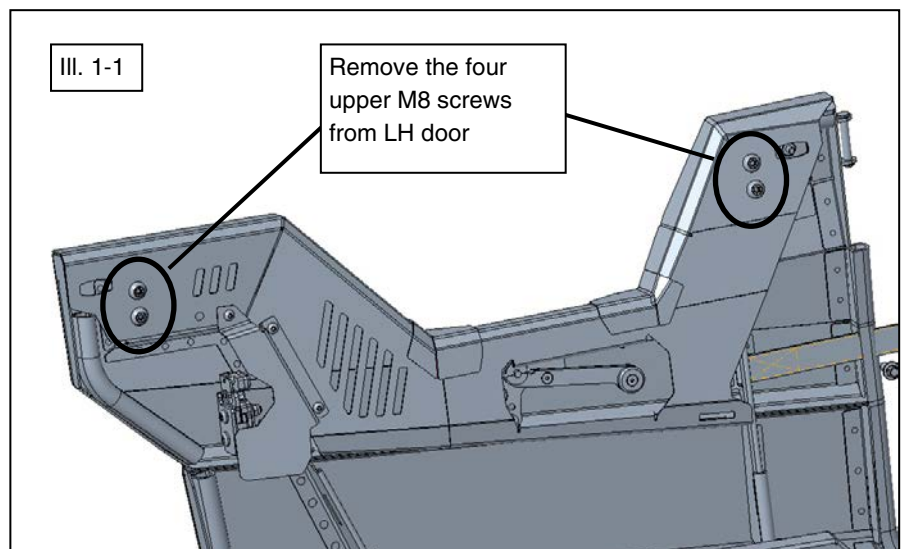

RANGER DOOR INSTALLATION:

4. Install the LH door assembly onto LH lower half door as shown. Loosely fasten using the previously removed M8 torx head screws. (See illustrations 1-2, 1-3 and 1-4). **Note, do not fully tighten at this step.**

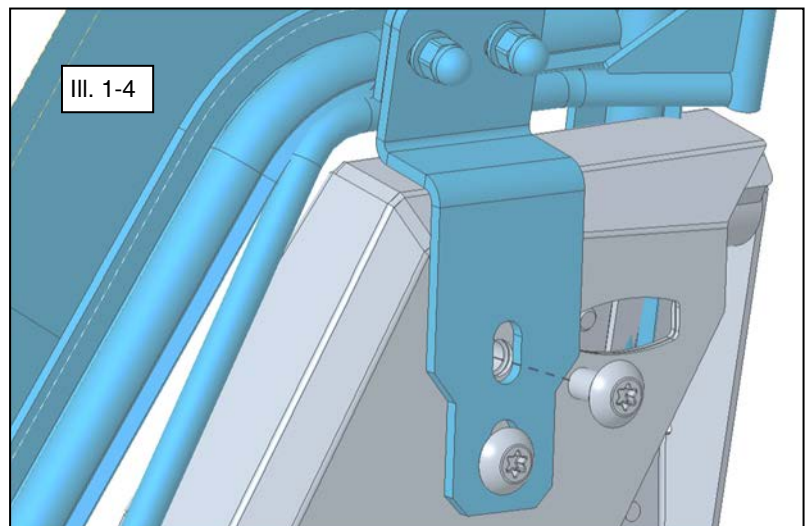
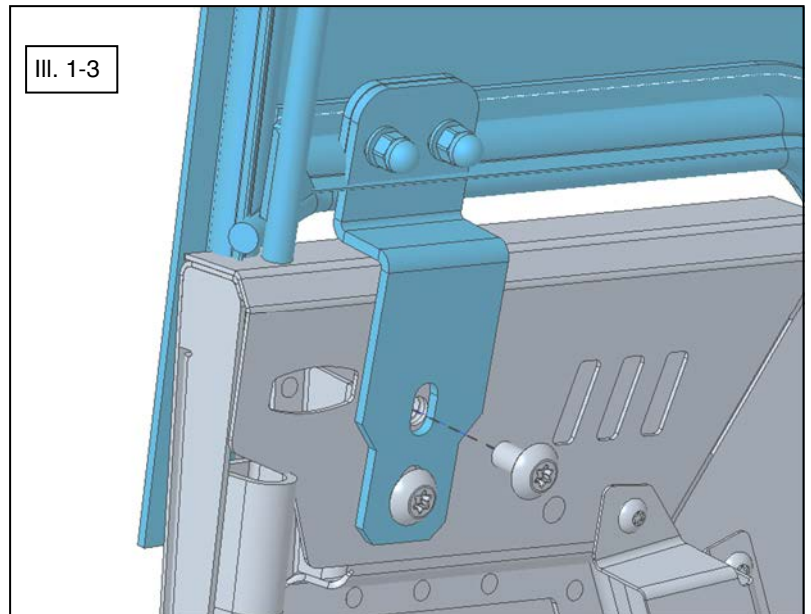
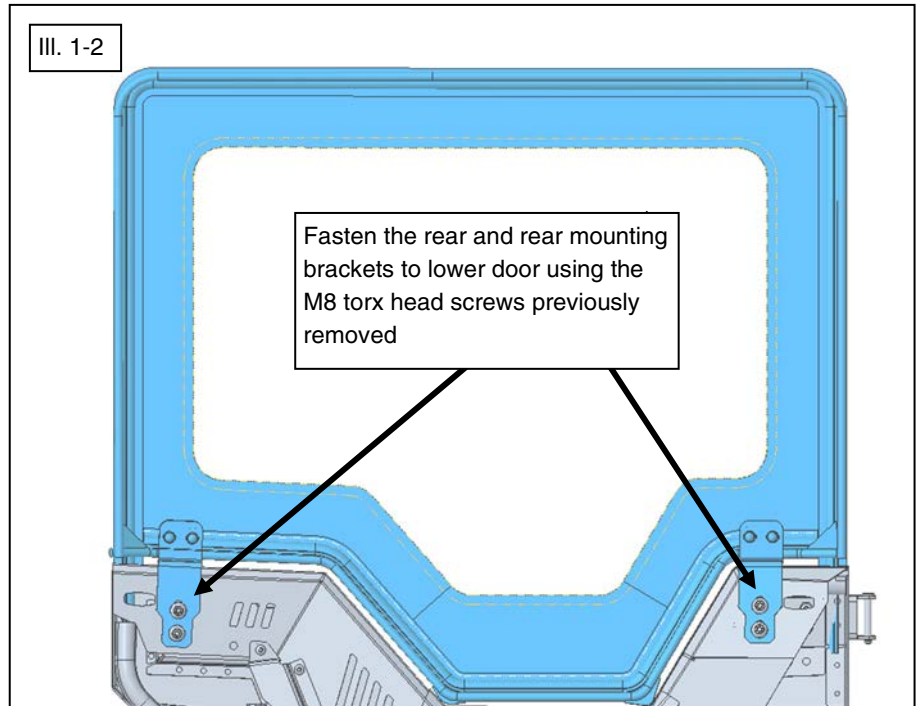

**RANGER DOOR INSTALLATION
(continued):**

- Slightly close door, pushing into ROPS, and observe gap between door frame and ROPS/chassis structure (around entire perimeter of door).

If Perimeter Gap Is Even:
Make sure upper door mating seal flange makes contact with lower door. If necessary, adjust height up or down with the adjustment available at M8 torx head screws. (See illustrations 1-5 and 1-6).

When complete, tighten all four M8 torx head screws to specification.

TIP

Have one person push and center the door, and a second person tighten the screws.

If Perimeter Gap Is Uneven:
Loosen the four acorn M6 nuts and center door in ROPS, then re-tighten to specification. When complete, go to previous section, If perimeter gap is even.

- Tighten to specifications noted.

 = T

**M8 TORX HEAD SCREW
FASTENER TORQUE:**
17 ft. lbs. (16.3 Nm)

 = T

**ITEM #9 M6 ACORN NUTS
FASTENER TORQUE:**
7 ft. lbs. (9.5 Nm)

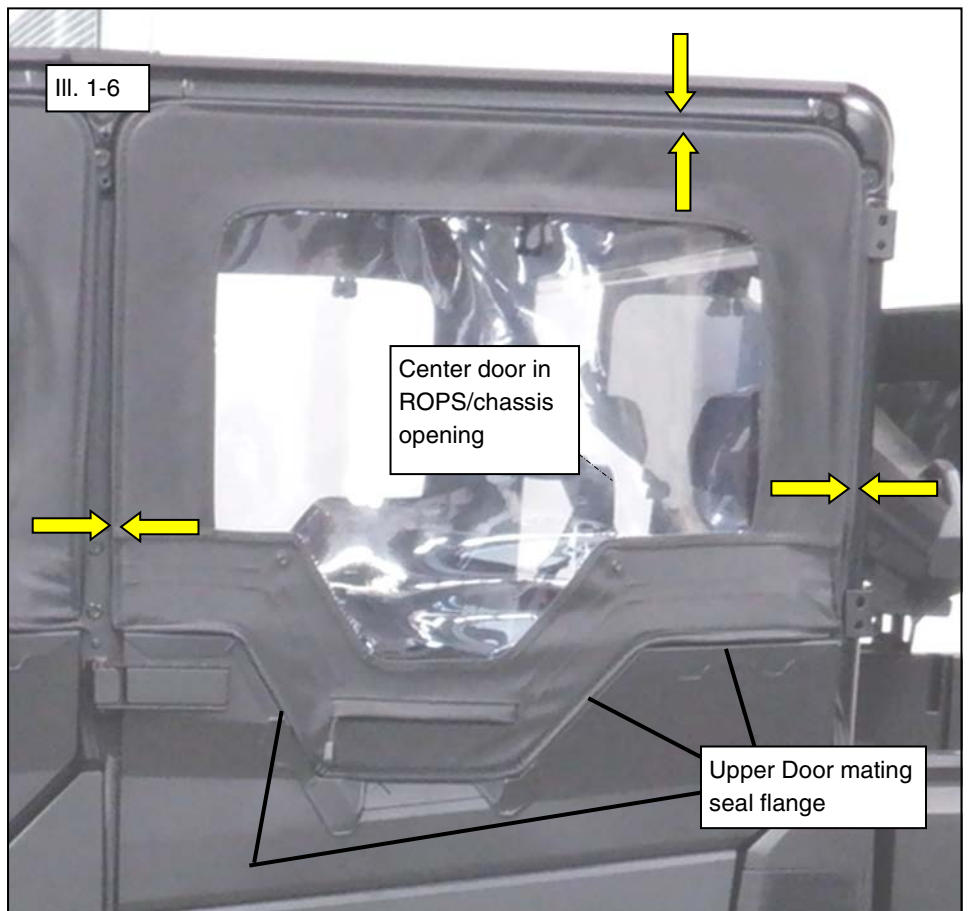
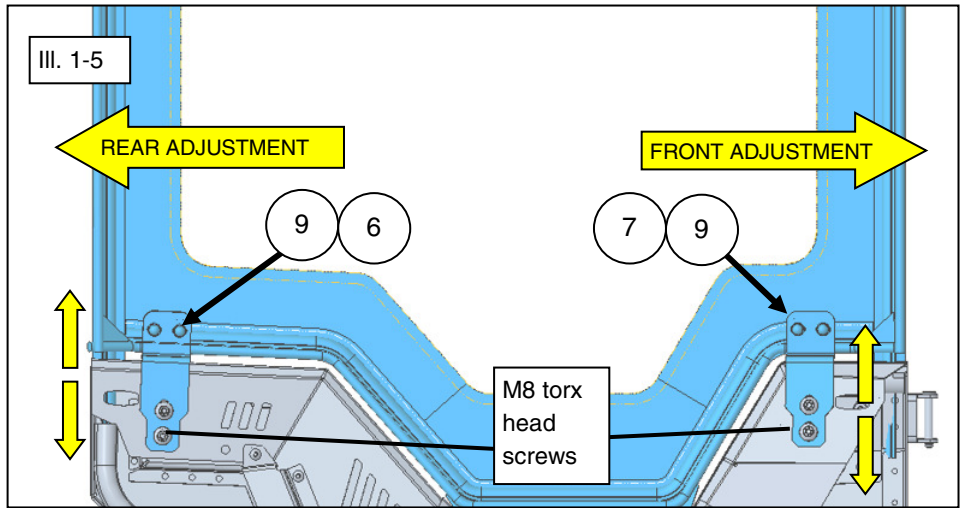

NOTE

Rear mounting bracket (item #6) and front mounting bracket (item #7) is pre-assembled to LH Door assembly.

RANGER DOOR INSTALLATION (continued):

7. The upper soft door assembly has double zippered handle access opening. Unzip to gain access to open door as shown. Open door latch handle (lifting up on orange handle), then slowly close door and observe engagement of striker pin into door latch. If lower door requires adjustment, follow procedure listed in 32010 instructions. (See illustrations 1-7 and 1-8).
8. Repeat steps 2-7 for the RH Upper Soft Door installation onto the RH lower half door.

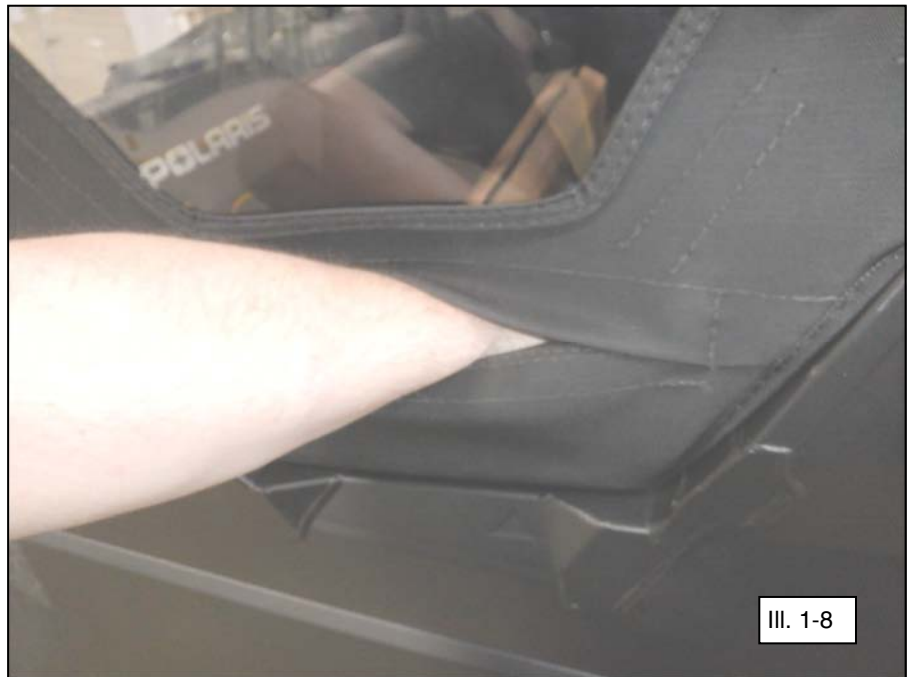
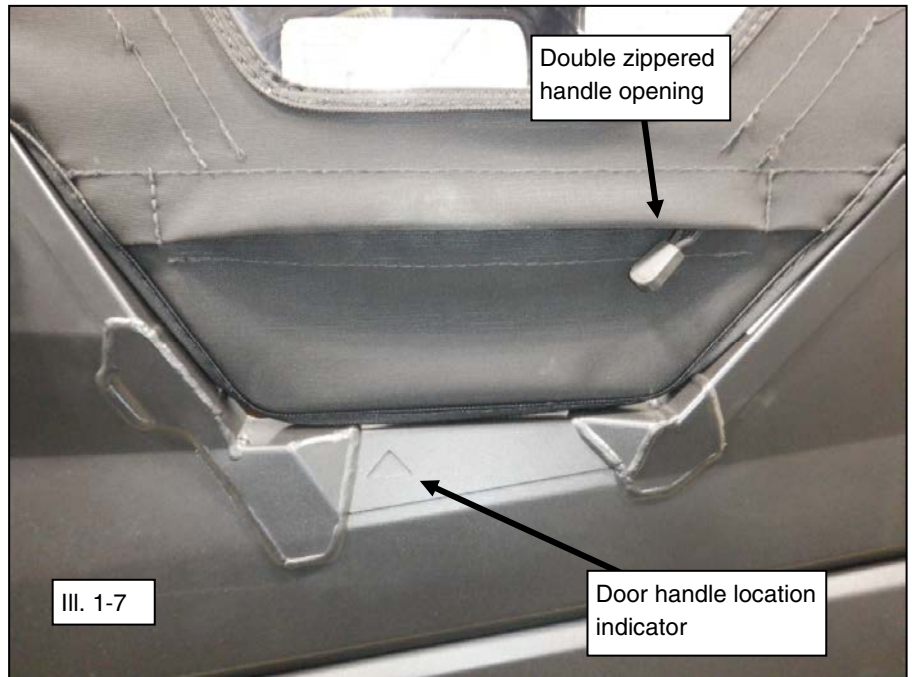

RANGER DOOR OPERATION:

9. This canvas upper door is recommended for use under the following conditions:

If Windshield is Fully Closed, then canvas windows can be open or closed, as desired.

If Windshield is Partially Open, then canvas windows should be partially open.

If Windshield is Fully Open, or no windshield is installed, then canvas windows should be fully open. (See illustration 1-9).

If Trailered on an Open Trailer, windshield must be installed and fully closed.

10. The upper soft door has a clear PVC film window that can be rolled down from inside or outside of the vehicle. The window has a button strap to store outside of vehicle when fully opened. (See illustration 1-9).



SERVICE KITS

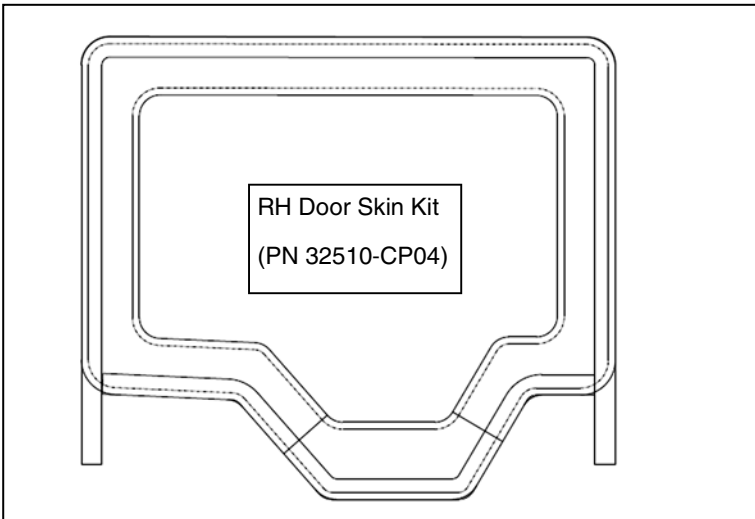
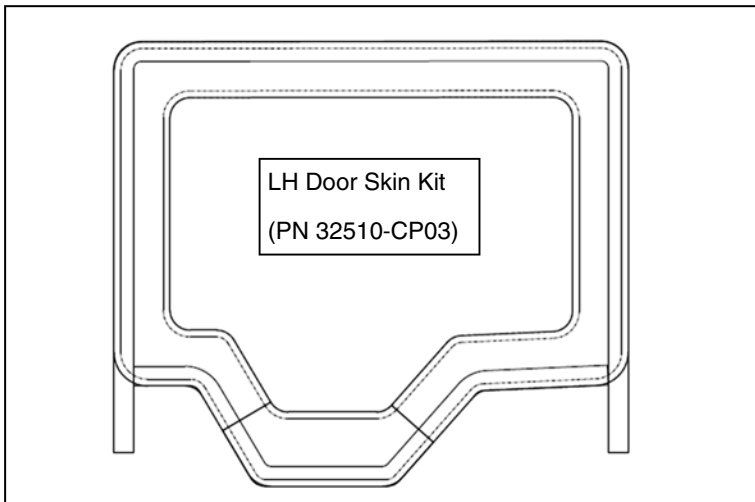

IMPORTANT
Upper doors not designed to withstand unrestricted air flow through cab.

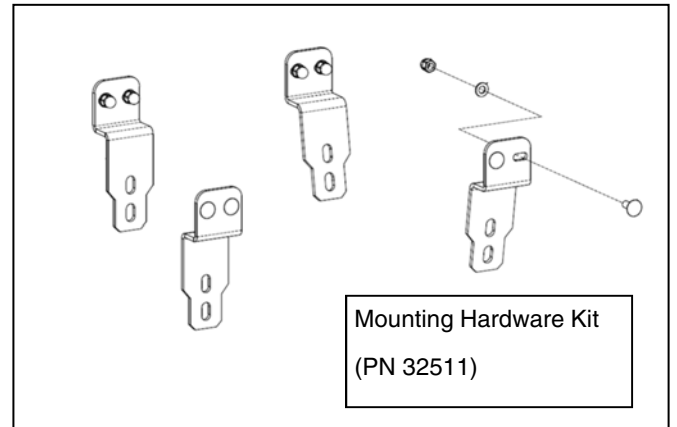

Use and Care Information:

- Check the accessory mounts frequently and retighten hardware if necessary.
- Replace this accessory with a new one if it is damaged.
- Never use petroleum solvents such as gasoline, thinner, benzene, acid or alkaline cleaners.

For additional assistance, please contact Kolpin customer service department at (877) 956-5746 or (763) 478-5800 or email customerservice@kolpin.com

One Year Limited Warranty

For the period of one (1) year from the purchase date, Kolpin will replace for the original purchaser, free of charge, any part or parts found upon examination by Kolpin to be defective in material, workmanship, or both.

All transportation costs incurred submitting product to Kolpin for warranty consideration must be borne by the purchaser. If Kolpin determines that the product must be returned to the factory for credit, please call 1-877-956-5746 for a Return Merchandise Authorization (RMA) number and shipping instructions.

This warranty does not apply to parts that have been damaged by accident, alteration, abuse, improper maintenance, normal wear, or other causes beyond the manufacturer's control. In order to protect you and your ATV, certain parts of the accessory system and/or hardware are designed to fail when the equipment is over-stressed. Parts that are lost due to loosening and improper maintenance are not covered under warranty. This warranty does not cover removal or reinstallation labor fees of the door system and related components.

Peripheral products such as engines, electric motors, and actuators may carry an original manufacturer's warranty. Most hardware is general in nature and is easily obtained locally. Be sure to replace with minimum metric class 8.8 specification.