

KOLPIN[®] OUTDOORS

PLOW MOUNT KIT

FOR HONDA PIONEER 500 / 700

P/N 34-1050

ASSEMBLY / OWNERS MANUAL

Application

PLOW PUSH FRAME NO. 34-0000 or 34-0070

Before you begin, please read these instructions and check to be sure all parts and tools are accounted for. The following instructions contain details required to install and service the contents of this kit.

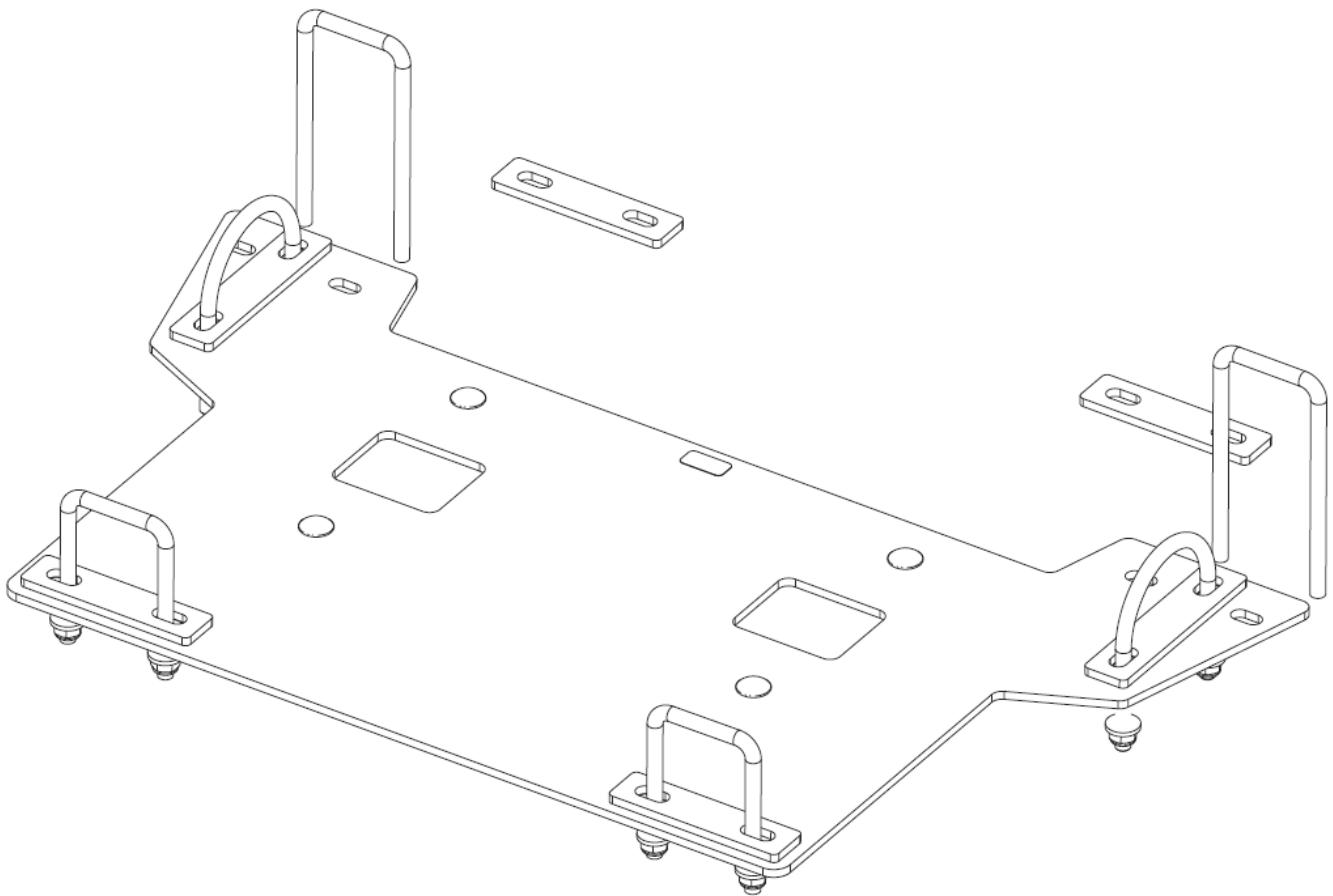

OPERATING INSTRUCTIONS

Congratulations! You've just purchased the most durable plow component in the industry. Kolpin plow components work great for summer or winter plowing. With proper care and maintenance, your Kolpin plow system will last for years to come!

NOTICE
Plow operation requires additional components for operation: <i>Kolpin Plow Blade, Kolpin Plow Push Frame, High Rise Plow Push Frame, Winch Kit</i> *
<i>*These components may be specific to your vehicle.</i>



Please read and understand all assembly instructions, notices and warnings before assembling and operating your Kolpin plow system.

Follow these guidelines to ensure satisfactory operation:

- Read this manual and your ATV/ UTV operators manual before use.
- Periodically check for wear and tightness of all fasteners. Replace or re-torque fasteners as necessary.
- Before first use, set plow in the furthest right or left angled position to check for interference with the vehicle.
- Operate with extreme caution on slopes and rough terrain. Be familiar with the area before you plow.
- Be aware of immovable objects that could be hidden in the area you are plowing.
- To avoid damage when pushing snow into a pile, reverse direction before raising the plow blade.
- Do not ram the plow blade into piles of snow.
- For best results, set the suspension preload of your ATV/ UTV to the stiffest setting.
- To reduce steering effort and increase mobility, set the air pressure of your tires to the maximum pressure specification.
- The plow skids are adjustable. General skid setting is even with the plow wear bar bottom edge, higher settings reduce the chance of rocks and gravel from being collected.
- To increase traction during plow operation, operators can try: Securing weight to the ATV/ UTV for additional tire downforce, reducing tire air pressure, or installing tire chains.

SAFETY INFORMATION

Our plow systems were designed with your safety in mind. Please read and understand all Cautions, Notices and Warnings in this manual before you begin. In order to protect you and your ATV/UTV, certain parts of the plow system and/or hardware are designed to fail when the equipment is over-stressed.

 WARNING 
TO AVOID SERIOUS INJURY OR DEATH:
1. DO NOT EXCEED 5 MPH (8 KMH) WITH BLADE INSTALLED
2. OPERATE WITH EXTREME CAUTION ON SLOPES, STEEP GRADES, AND ROUGH TERRAIN
3. ALLOW NO RIDERS ON BLADE OR ATV WHILE MOVING OR STATIONARY
4. KEEP BYSTANDERS AWAY FROM THE BLADE OR ATV WHILE MOVING OR STATIONARY
5. WHEN PUSHING HEAVY MATERIAL, DIRECTION CONTROL MAY BECOME DIFFICULT
6. BEFORE ADJUSTING BLADE: STOP ATV ENGINE; SET AND LOCK BRAKES; RAISE AND LOCK BLADE
7. LOWER BLADE TO DOWN POSITION WHEN BLADE AND ATV ARE NOT IN USE
8. READ BLADE INSTRUCTION SHEETS AND ATV OWNER'S MANUAL

Kit Contents:

Item	Qty	Part Description	Part Number
1	1	Pioneer Mount Plate	-
2	4	Spacer Bracket for Square U-bolt	-
3	2	Round U-Bolt, Zinc Plated, M8-1.25 x 2.75" Wide	-
4	2	Square U-Bolts, 131mm	-
5	2	Square U-Bolts, 93mm	-
6	4	Carriage Bolt, Zinc Plated, M8-1.25 x 25mm LG	-
7	2	Spacer Bracket for Round U-bolt	-
8	12	Flange Locknut, Zinc Plated, M8-1.25	-
9	1	Instruction Guide (not shown)	-

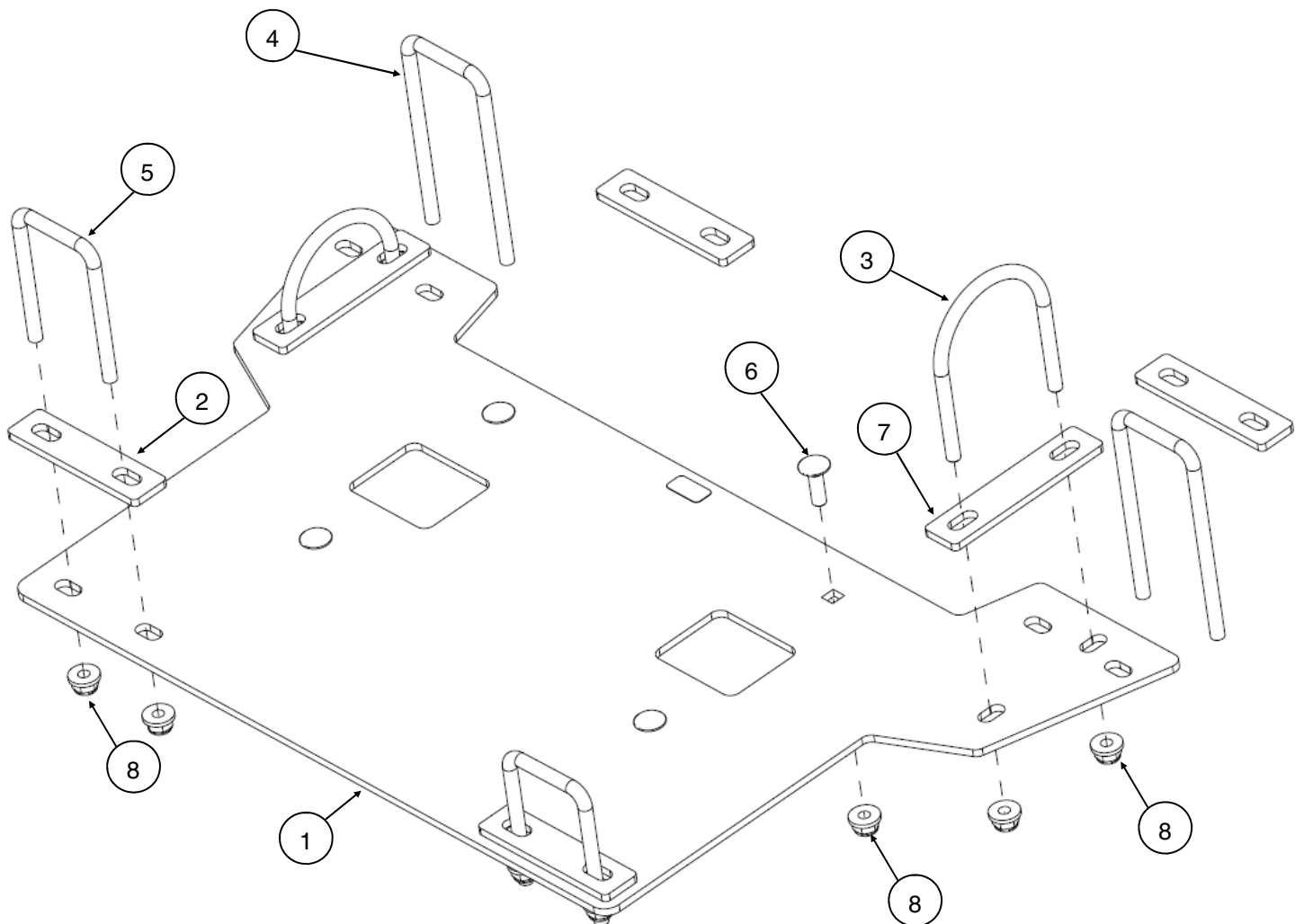

BEFORE YOU BEGIN:

- Your Kolpin accessory is exclusively designed for your vehicle
- Please read and understand all instructions
- Verify all parts and tools are accounted for
- To ensure a satisfactory installation, follow all steps correctly and in the sequence described
- Keep these instructions for future reference or for informational requests
- To facilitate installation, make sure that your vehicle is clean and free of debris
- All directions referring to right and left are when the rider is sitting on the machine
- The plastic skid plate will need to be modified to be reinstalled on the vehicle.

TOOLS REQUIRED:

- Basic Metric Wrench and Socket Set
- Drill or cutting tools for plastic

APPROXIMATE ASSEMBLY TIME: 30 minutes

Note: Removal and modification of the plastic skid plate is recommended.

Note: If any hardware is missing, do not return to the store. Call us to help, Toll Free 1-877-956-5746.

SPARE KITS		Hardware kit P/N 34-0012
Item	Description	
4	Square U-Bolts, 131mm	4x
6	Carriage Bolt, Zinc Plated, M8-1.25 x 25mm LG	4x
8	Flange Locknut, Zinc Plated, M8-1.25	12x
-	Hex Bolt, Zinc Plated, M8-1.25 35mm LG	3x
-	Flat Washer, Zinc Plated, M8	3x
-	Serrated Nut, Zinc Plated, M8-1.25	2x

Spare Kit Notes:

- Spare kits may contain extra hardware that is used for other mount kits. Extra hardware can be discarded.
- U-bolts supplied in spare kits may be longer than original and may need to be cut to size.

Installation Preparation Pioneer 500:

1. From under the vehicle, locate the front plastic skid plate as shown. (See illustration 1-1).
2. Use the Pioneer Mount Plate (item #1) as a pattern to mark the mounting holes into the plastic skid plate. Align the mount plate just behind the lower control arm rear pivot tab as shown. (See illustration 1-2).
3. Scribe or mark holes in the locations as shown (See illustration 1-3). **Note, the horizontal slots are for the Pioneer 500 u-bolt pattern. The mix of horizontal and vertical slots are for the Pioneer 700 u-bolt pattern.**
4. Detach the plastic skid plate from the vehicle by removing the OEM hardware and save for re-installation later.
5. Drill holes through the skid plate at locations marked. Use a 3/8" to 1/2" bit to create an oversized hole that will allow some relief when installing hardware. **Note, a high speed cutting tool (like a Dremel) with a cutting bit will also work. (See Illustration 1-4).**

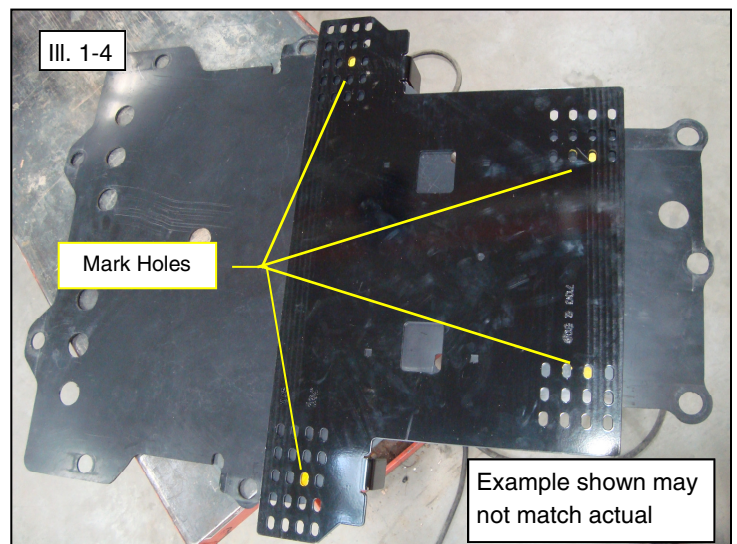
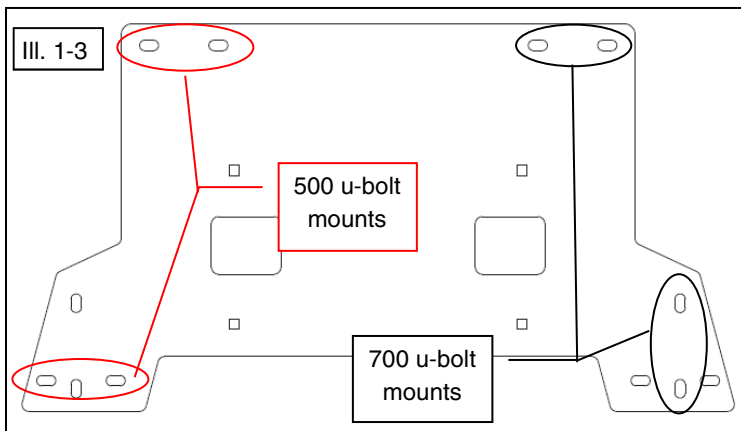
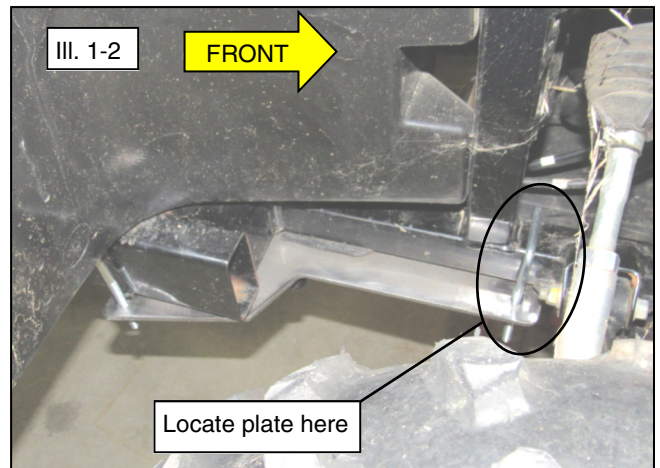
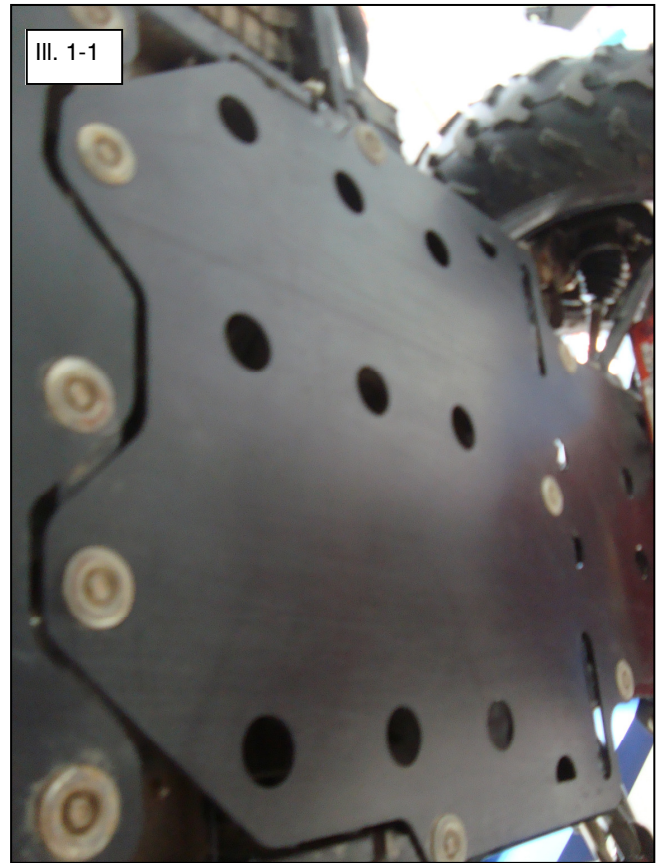

Installation Preparation Pioneer 700:

1. Use the Pioneer Mount Plate (item #1) as a pattern to mark the mounting holes into the plastic skid plate. From under the vehicle, align the mount plate just ahead the lower control arm rear pivot tab as shown. (See illustration 1-5).
2. Scribe or mark holes in the locations as shown (See illustrations 1-5, 1-6 and 1-7). **Note, the horizontal slots are for the Pioneer 500 u-bolt pattern. The mix of horizontal and vertical slots are for the Pioneer 700 u-bolt pattern.**
3. Detach the plastic skid plate from the vehicle by removing the OEM hardware and save for re-install later. (See illustrations 1-6 and 1-8).
4. Drill holes through the skid plate at locations marked. Use a 3/8" to 1/2" bit to create an oversized hole that will allow some relief when installing hardware. **Note, a high speed cutting tool (like a Dremel) with a cutting bit will also work. (See illustration 1-8).**

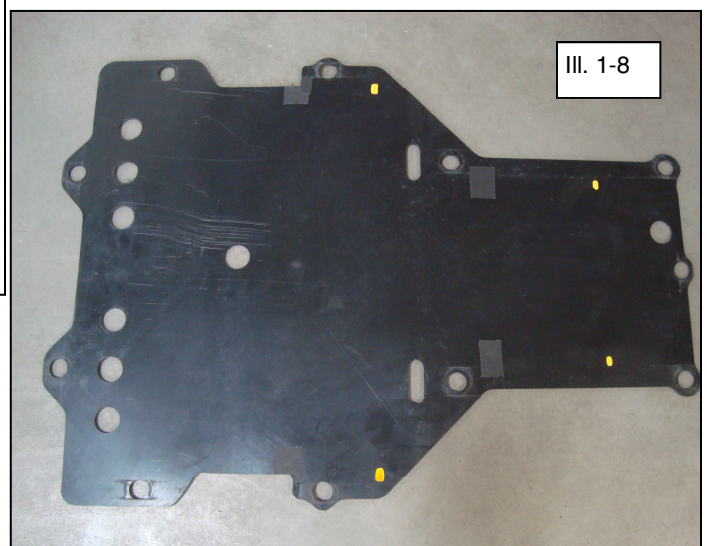
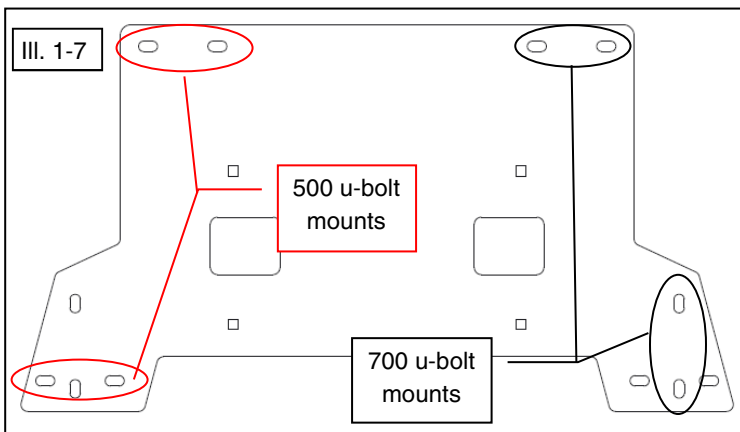
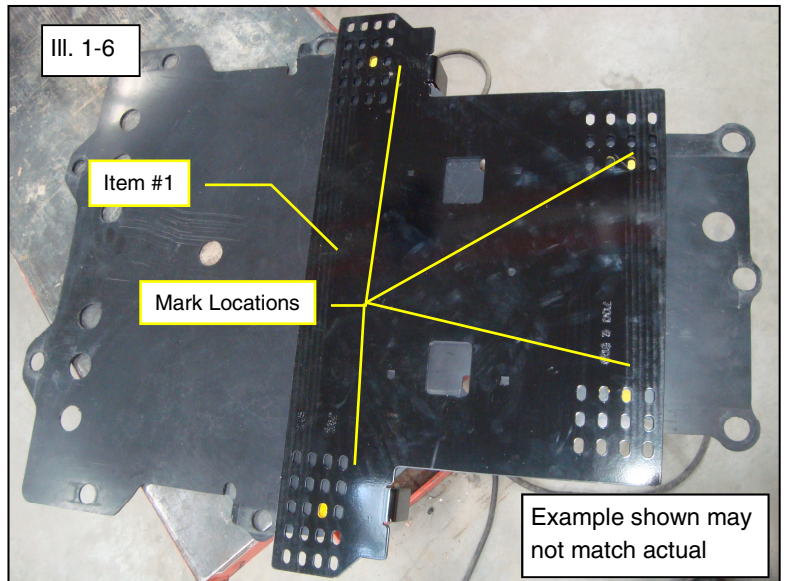
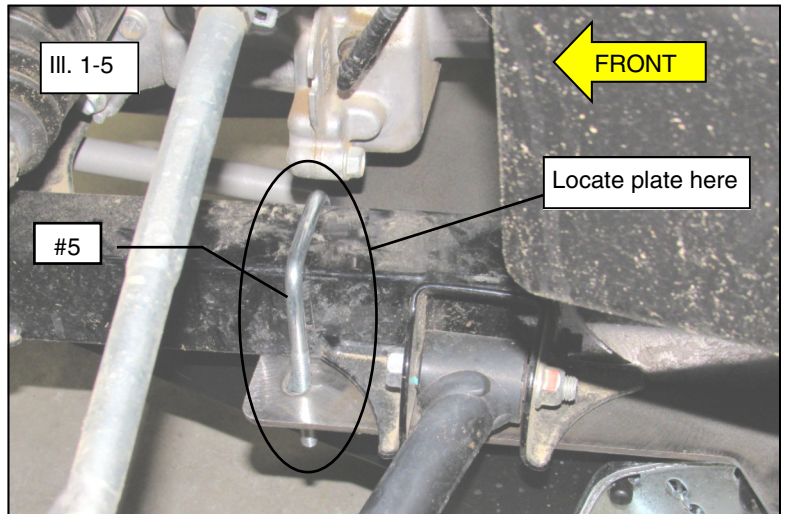

Mount Plate Installation:

1. **For Pioneer 500 only:** Remove the OEM screws and plastic push dart rivets to allow for clearance to fit u-bolt between the passenger floorboard and the frame tube as shown (See illustration 2-1).
2. **For Pioneer 500 only:** Insert the square 131 mm U-bolts (item #4) and the square 93 mm U-bolts (item #5) around the frame tubes as shown. Re-install the skid plate onto the vehicle with the OEM hardware. The u-bolts will fit thru the holes in the skid plate as shown (See illustrations 2-2 and 2-3).
3. **For Pioneer 700 only:** Insert the square 93mm u-bolts (item #5) around the front frame as shown and insert the round u-bolts (item #3) around the round tube frame cross member. Re-install the skid plate onto the vehicle with the OEM hardware. The u-bolts will fit thru the holes in the skid plate. (See illustrations 1-5, 2-4 and 2-5).

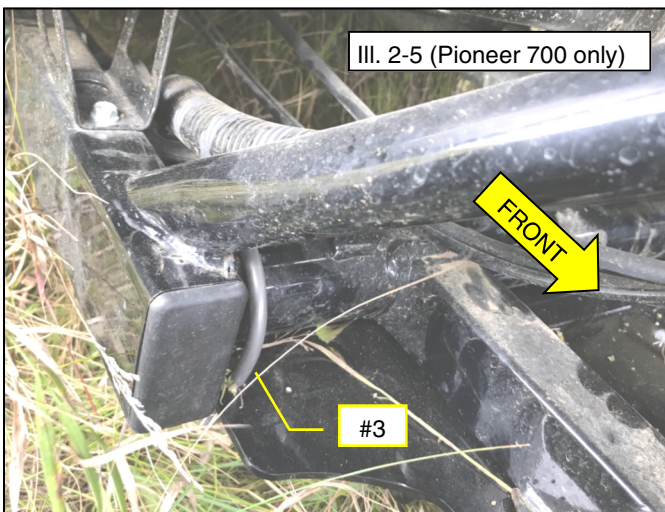
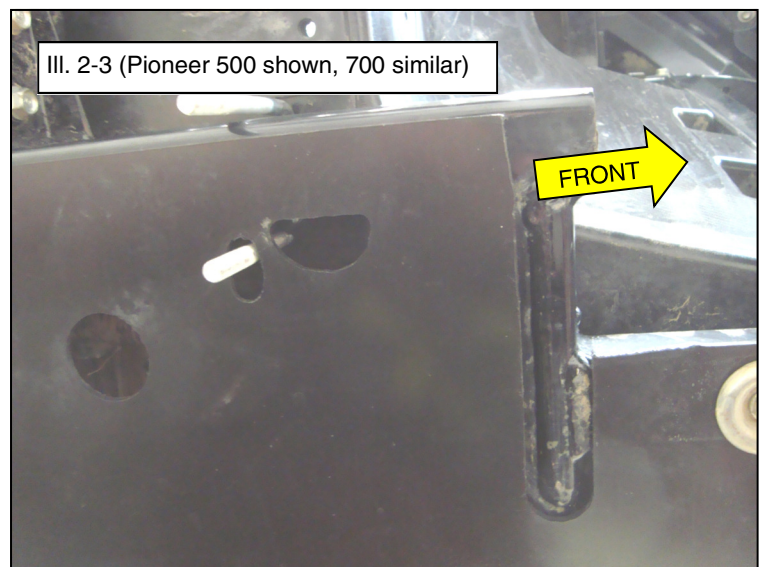
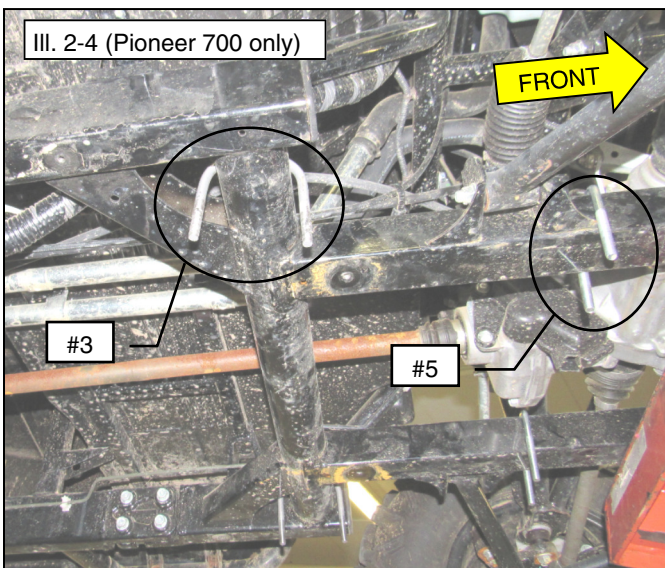
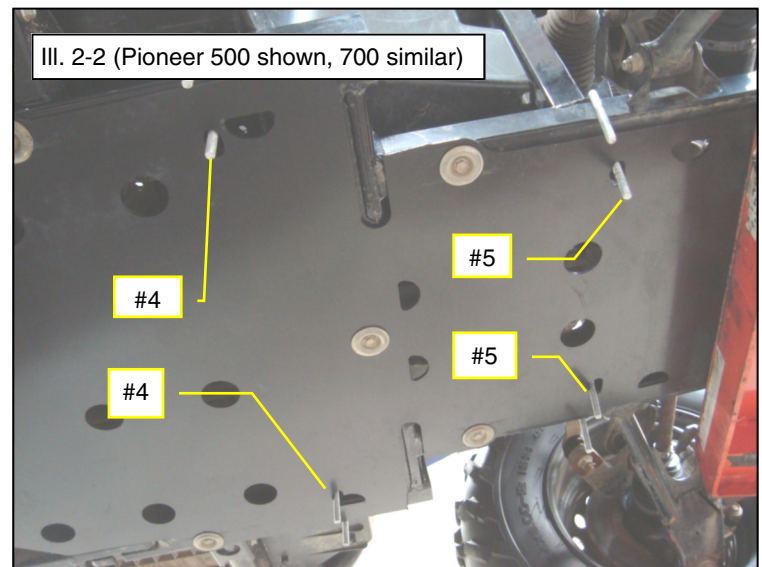
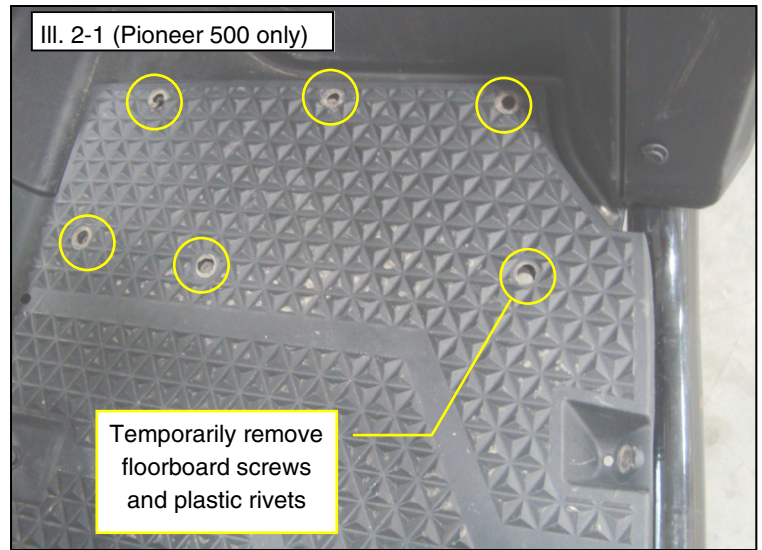

Mount Plate Installation (cont'd):

4. **For Pioneer 500 only:** Place the spacer brackets (item #2) onto the four square u-bolts as shown. The spacers will fit in between the plastic skid plate and the mount plate (item #1). (See illustration 2-6).
5. **For Pioneer 700 only:** Place the spacer brackets (item #7) onto the two round square u-bolts and place the spacer brackets (item #2) onto the two square u-bolts. The spacers will fit in between the plastic skid plate and the mount plate (item #1).
6. Install the Pioneer Mount Plate (item #1) onto the vehicle. The u-bolts will fit thru holes in the plate as shown. Fasten the u-bolts threads with the M8 locknuts (item #8). Insert the M8 carriage bolts (item #6) thru the plate as shown. (See illustrations 2-7).

Note, do not tighten at this step.

7. Tighten the M8 locknuts (item #8) for securing the U-bolts, (items #3, #4 and #5). Use caution to not overtighten u-bolts. The excess threads can be trimmed, but leave 3-4 threads exposed past the locknut. (See illustrations 2-7 and 2-8).
8. The universal mount plate, not included in this kit, will be attached to the Pioneer mount plate as shown. The M8 carriage bolts will fasten the universal plate with the M8 locknuts (item #4). Tighten to M8 specification. (See illustrations 2-7 and 2-8).

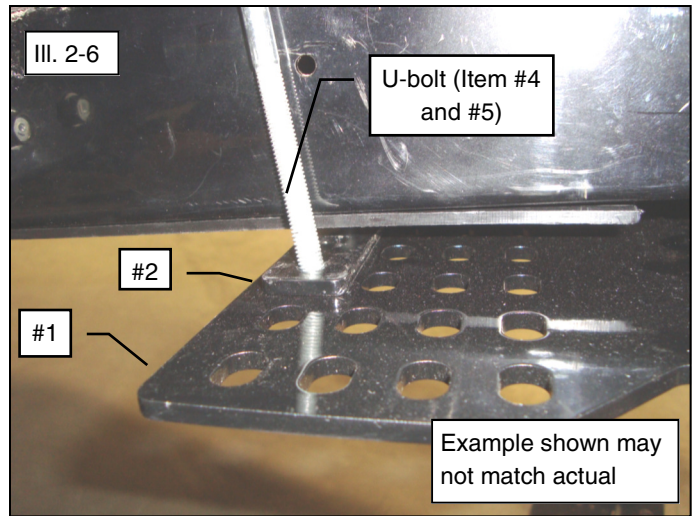

 = T
8MM FASTENER TORQUE:
 17 ft. lbs. (23 Nm)

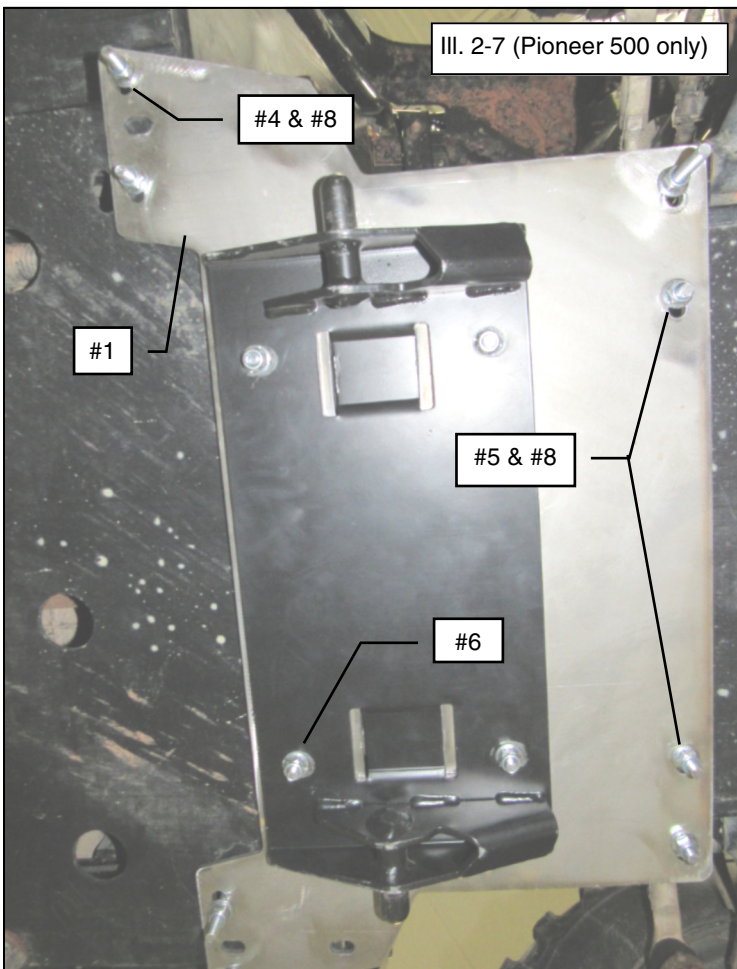



One Year Limited Warranty

For the period of one (1) year from the purchase date, Kolpin will replace for the original purchaser, free of charge, any part or parts found upon examination by Kolpin to be defective in material, workmanship, or both.

All transportation costs incurred submitting product to Kolpin for warranty consideration must be borne by the purchaser. If Kolpin determines that the product must be returned to the factory for credit, please call 1-877-956-5746 for a Return Merchandise Authorization (RMA) number and shipping instructions.

This warranty does not apply to parts that have been damaged by accident, alteration, abuse, improper maintenance, normal wear, or other causes beyond the manufacturer's control. In order to protect you and your ATV, certain parts of the plow system and/or hardware are designed to fail when the equipment is over-stressed. Parts that are lost due to loosening and improper maintenance are not covered under warranty. This warranty does not cover removal or reinstallation labor fees of the plow system and related components.

Peripheral products such as engines, electric motors, and actuators may carry an original manufacturer's warranty. Most hardware is general in nature and is easily obtained locally. Be sure to replace with minimum metric class 8.8 specification.

Kolpin Outdoors, Inc.

Telephone: (763)-478-5800

Toll Free: (877)-956-5746

Fax Number: (800)-245-7569

www.kolpin.com

Email: customerservice@kolpin.com