



PLOW MOUNT KIT

FOR KAWASAKI TERYX, YAMAHA RHINO

P/N 34-2025

ASSEMBLY / OWNERS MANUAL

Application

PLOW PUSH FRAME NO. 34-0000 or 34-0070

Before you begin, please read these instructions and check to be sure all parts and tools are accounted for. The following instructions contain details required to install and service the contents of this kit.

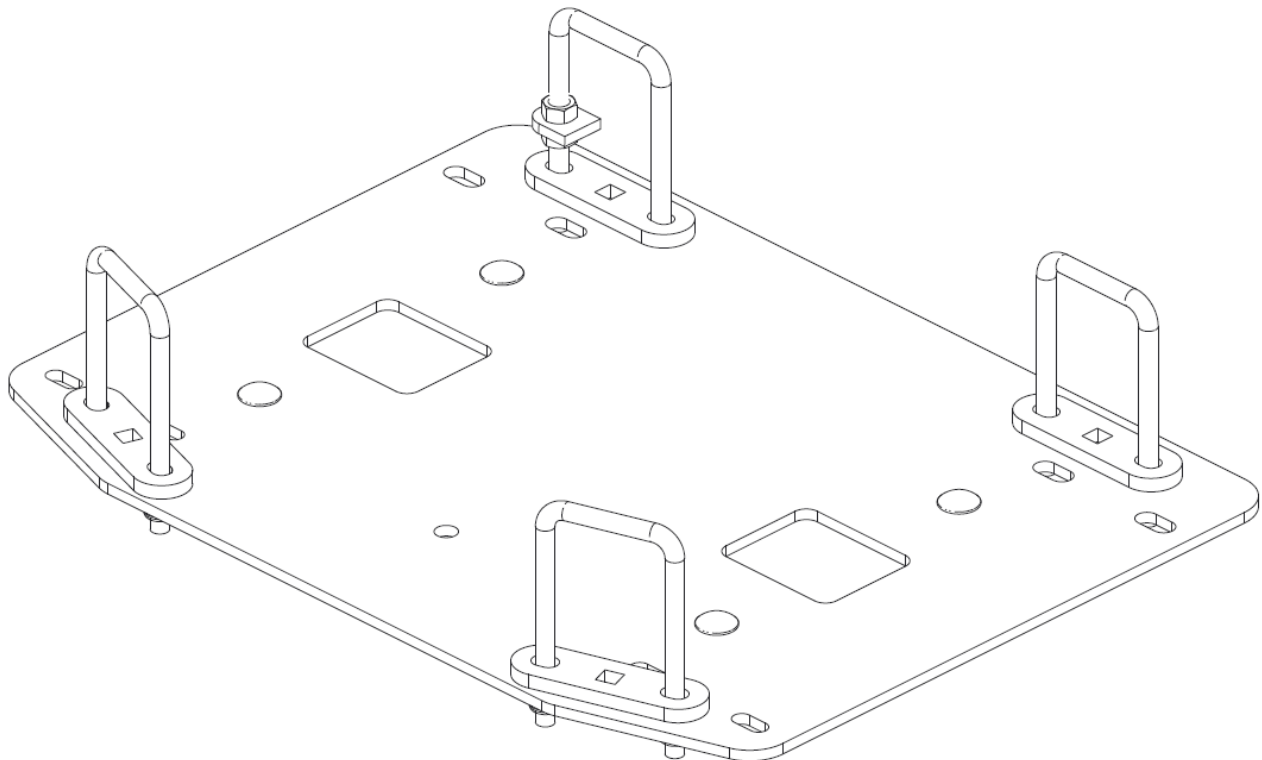

OPERATING INSTRUCTIONS

Congratulations! You've just purchased the most durable plow component in the industry. Kolpin plow components work great for summer or winter plowing. With proper care and maintenance, your Kolpin plow system will last for years to come!

NOTICE

Plow operation requires additional components for operation: *Kolpin Plow Blade, Kolpin Plow Push Frame, High Rise Plow Push Frame, Winch Kit* *

**These components may be specific to your vehicle.*

Please read and understand all assembly instructions, notices and warnings before assembling and operating your Kolpin plow system.

Follow these guidelines to ensure satisfactory operation:

- Read this manual and your ATV/ UTV operators manual before use.
- Periodically check for wear and tightness of all fasteners. Replace or re-torque fasteners as necessary.
- Before first use, set plow in the furthest right or left angled position to check for interference with the vehicle.
- Operate with extreme caution on slopes and rough terrain. Be familiar with the area before you plow.
- Be aware of immovable objects that could be hidden in the area you are plowing.
- To avoid damage when pushing snow into a pile, reverse direction before raising the plow blade.
- Do not ram the plow blade into piles of snow.
- For best results, set the suspension preload of your ATV/ UTV to the stiffest setting.
- To reduce steering effort and increase mobility, set the air pressure of your tires to the maximum pressure specification.
- The plow skids are adjustable. General skid setting is even with the plow wear bar bottom edge, higher settings reduce the chance of rocks and gravel from being collected.
- To increase traction during plow operation, operators can try: Securing weight to the ATV/ UTV for additional tire downforce, reducing tire air pressure, or installing tire chains.

SAFETY INFORMATION

Our plow systems were designed with your safety in mind. Please read and understand all Cautions, Notices and Warnings in this manual before you begin. In order to protect you and your ATV/UTV, certain parts of the plow system and/or hardware are designed to fail when the equipment is over-stressed.



DANGER



TO AVOID SERIOUS INJURY OR DEATH:

1. **DO NOT EXCEED 5 MPH (8 KMH) WITH BLADE INSTALLED.**
2. **OPERATE WITH EXTREME CAUTION ON SLOPES, STEEP GRADES, AND ROUGH TERRAIN.**
3. **ALLOW NO RIDERS ON BLADE OR ATV/UTV WHILE MOVING OR STATIONARY.**
4. **KEEP BYSTANDERS AWAY FROM THE BLADE OR ATV/UTV WHILE MOVING OR STATIONARY.**
5. **WHEN PUSHING HEAVY MATERIAL, DIRECTION CONTROL MAY BECOME DIFFICULT.**
6. **BEFORE ADJUSTING BLADE: STOP ATV/UTV ENGINE; SET AND LOCK BRAKES; RAISE AND LOCK BLADE IN UP POSITION. DO NOT ATTEMPT TO RAISE BLADE BY HAND; USE THE LIFT MECHANISM ONLY.**
7. **LOWER BLADE TO DOWN POSITION WHEN BLADE AND ATV/UTV ARE NOT IN USE.**
8. **READ BLADE'S INSTRUCTION SHEETS AND ATV/UTV OWNER MANUAL.**

Kit Contents:

Item	Qty	Part Description	Part Number
1	1	Teryx Rhino Mount Plate	-
2	4	Square U-Bolts	-
3	4	Spacer Bracket	-
4	12	Flange Locknut, Zinc Plated, M8-1.25	-
5	4	Carriage Bolt, Zinc Plated, M8-1.25 x 25mm LG	-
6	2	Serrated Nut, Zinc Plated, M8-1.25	-
7	1	Brakeline Protector Spacer	-
8	1	Instruction Guide (not shown)	-

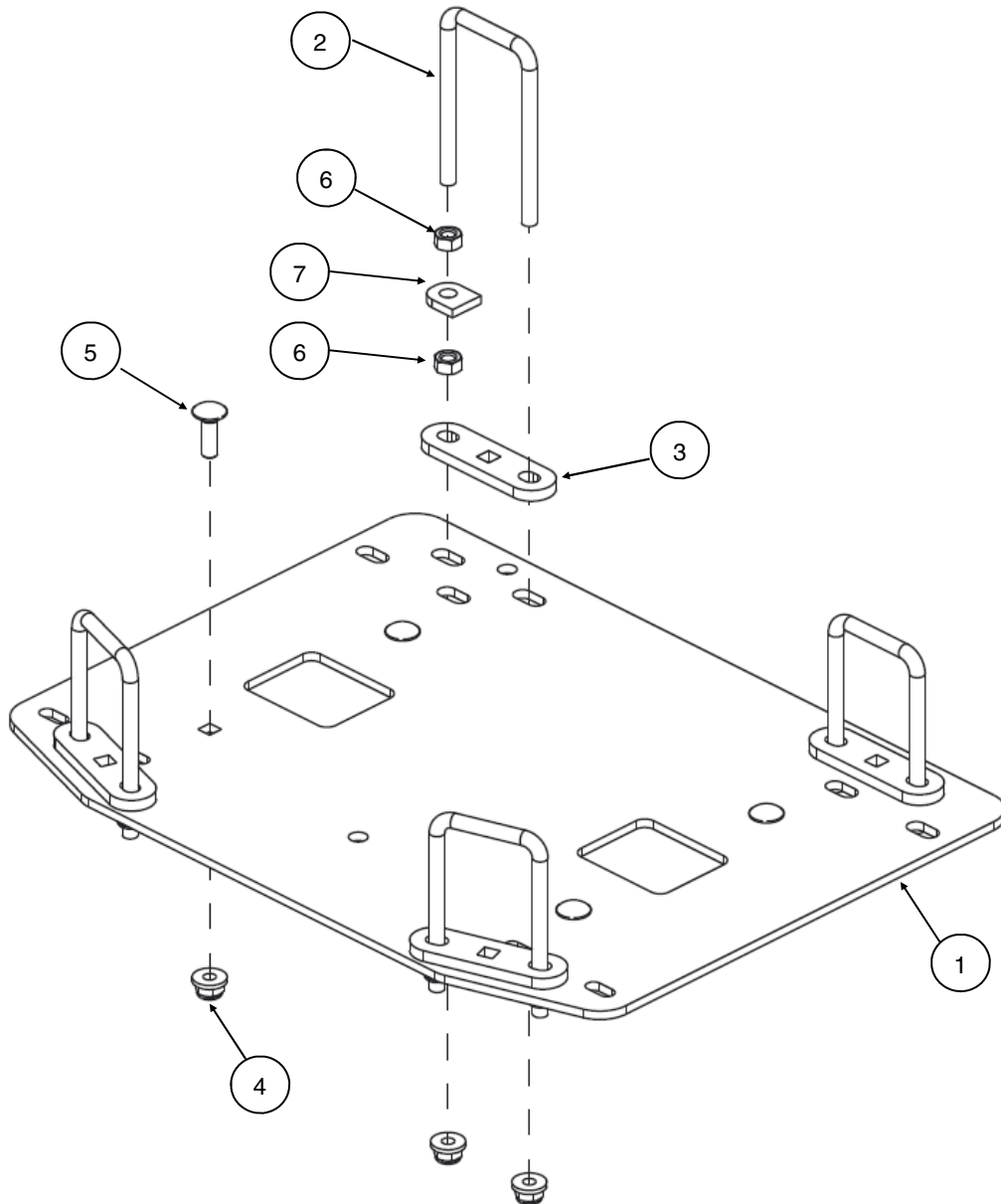

BEFORE YOU BEGIN:

- Your Kolpin accessory is exclusively designed for your vehicle
- Please read and understand all instructions
- Verify all parts and tools are accounted for
- To ensure a satisfactory installation, follow all steps correctly and in the sequence described
- Keep these instructions for future reference or for informational requests
- To facilitate installation, make sure that your vehicle is clean and free of debris
- All directions referring to right and left are when the rider is sitting on the machine
- The plastic skid plate will need to be modified to be reinstalled on the vehicle.

TOOLS REQUIRED:

- 10mm Socket
- 13mm Wrench and 13mm Socket
- #3 Phillips Screwdriver
- Drill or cutting tools for plastic and metal

APPROXIMATE ASSEMBLY TIME: 30 minutes

Note: Removal and modification of the plastic skid plate is recommended.

Note: If any hardware is missing, do not return to the store. Call us to help, Toll Free 1-877-956-5746.

SPARE KITS		Hardware kit P/N 34-0010
Item	Description	
2	Square U-Bolts	4x
4	Flange Locknut, Zinc Plated, M8-1.25	12x
5	Carriage Bolt, Zinc Plated, M8-1.25 x 25mm LG	4x
6	Hex Nut, Zinc Plated, M8-1.25	2x
-	Hex Bolt, Zinc Plated, M8-1.25 45mm LG	2x
-	Hex Bolt, Zinc Plated, M8-1.25 90mm LG	2x
-	Carriage Bolt, Zinc Plated, M10-1.5 x 40mm LG	2x
-	Flange Locknut, Zinc Plated, M10-1.5	2x
-	Spring Lock Washer, Zinc Plated, M8	2x
-	Flat Washer, Zinc Plated, M8	2x

Spare Kit Notes:

- Spare kits may contain extra hardware that is used for other mount kits. Extra hardware can be discarded.
- U-bolts supplied in spare kits may be longer than original and may need to be cut to size.

Teryx Installation Prep:

1. From under the vehicle, remove the three screws that secure the plastic skid plates to the frame as shown. (See illustration 1-1).
2. Use the mount plate (item #1) as a pattern to mark the hardware locations into the plastic skid plates.
3. Align the three holes in the mount plate (item #1) with the removed screw locations for the plastic skid plate as shown. (See illustration 1-2).
4. Scribe or mark the u-bolt hole locations onto the plastic skid plates as shown. **Note, the inner slotted holes are for the Teryx u-bolt mount pattern. The outer slotted holes are for the Rhino u-bolt mount pattern.** (See illustration 1-3).

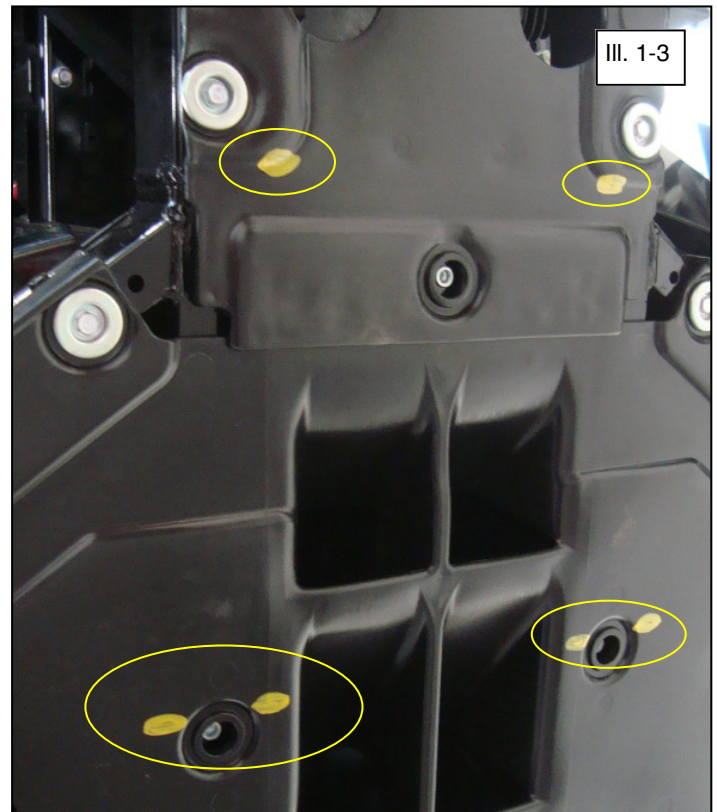
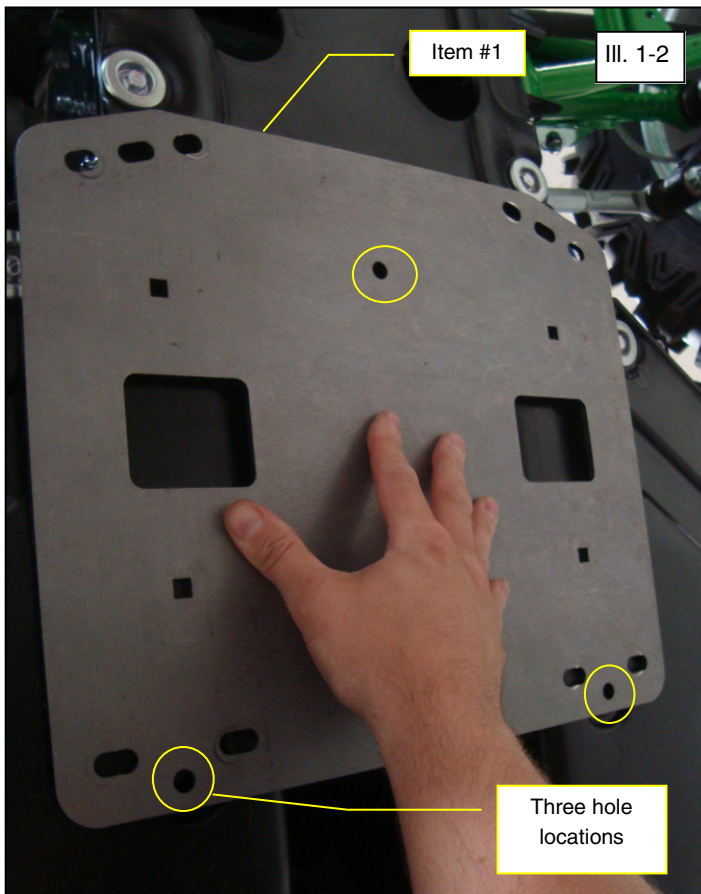
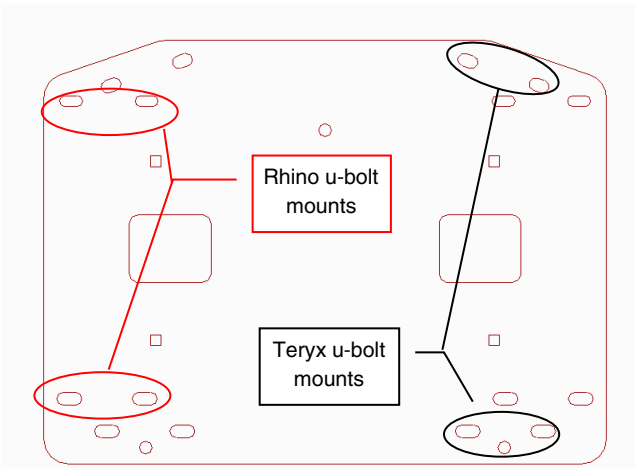
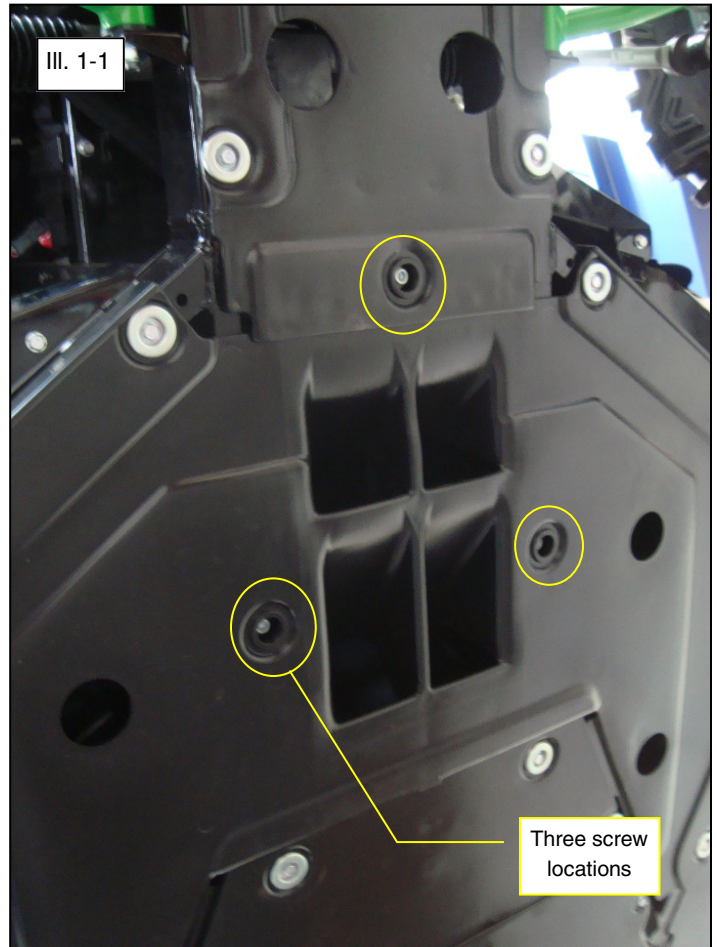

Teryx Installation Prep (continued):

5. Detach the plastic skid plates from the vehicle by removing the OEM hardware and save for re-install later. (See illustration 1-4).
6. Drill holes through the skid plates at locations marked. Use a 3/8" to 1/2" bit to create an oversized hole that will allow some relief when installing hardware. **Note, a high speed cutting tool (like a Dremel) with a cutting bit will also work.**
7. From inside the vehicle cab (driver's side), remove the OEM hardware as shown. Save for re-install later. This will allow for clearance to fit u-bolt between the floorboard and the frame tube. (See illustration 1-5).

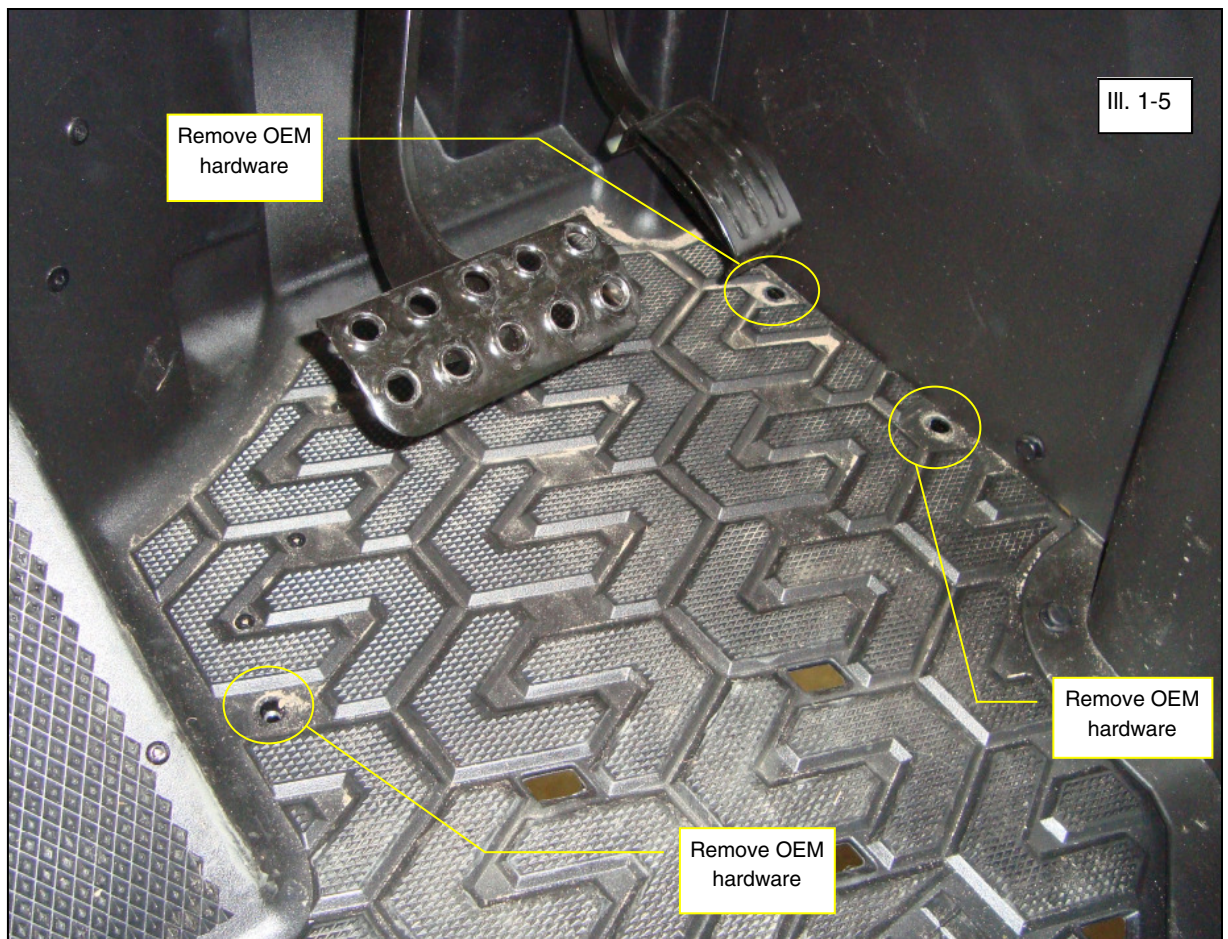
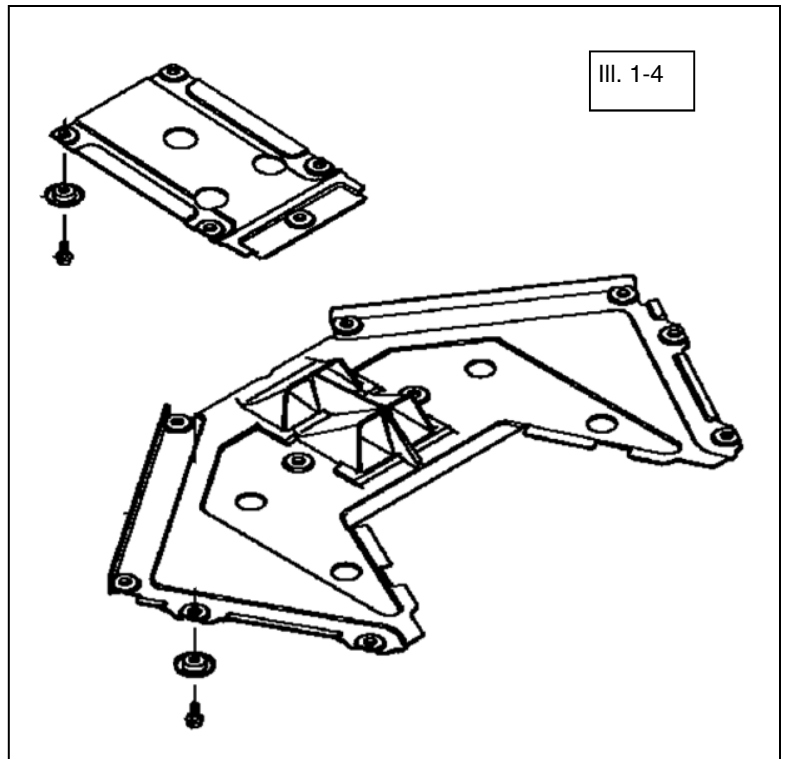

Teryx Mount Plate Installation:

1. Using the mount plate (item #1) as a pattern to locate the u-bolt locations as shown. (See illustration 2-1).
2. From under the vehicle, position the u-bolts (item #2) around the frame in the locations shown. (See illustration 2-2).
3. *For the right rear u-bolt, a brakeline spacer is required. (See Illustration 2-2 and 2-3).*
4. *Position the right rear u-bolt around the frame and brakeline as shown. Thread the first serrated nut, item #6, onto the u-bolt. Then insert the brakeline protector, item #7, onto the u-bolt and fasten with second serrated nut, item #6. (See Illustrations 2-3 and 2-4).*

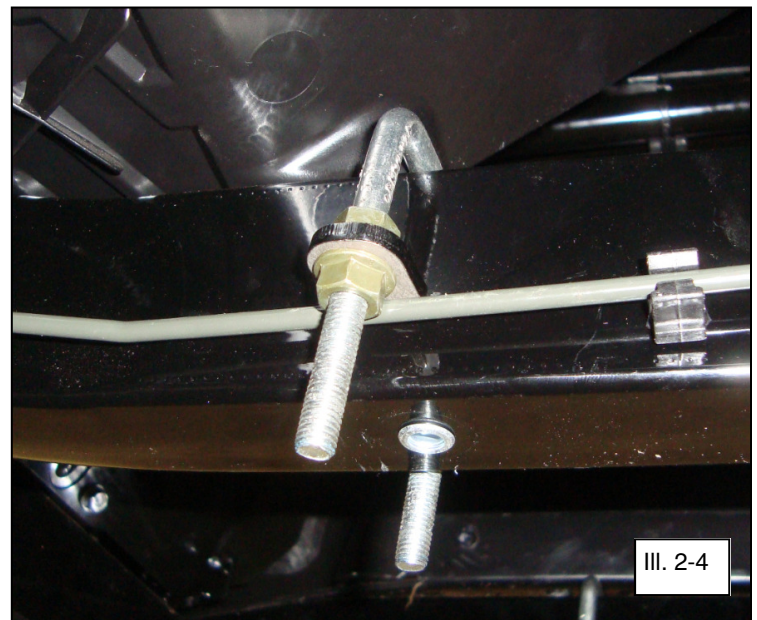
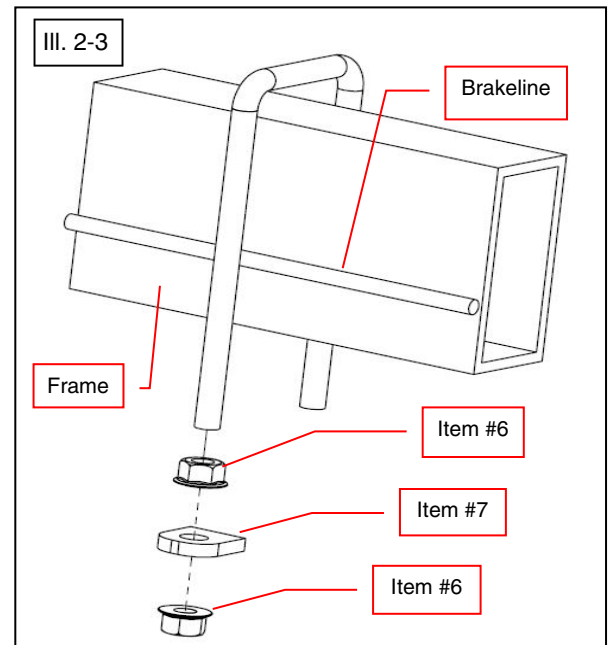
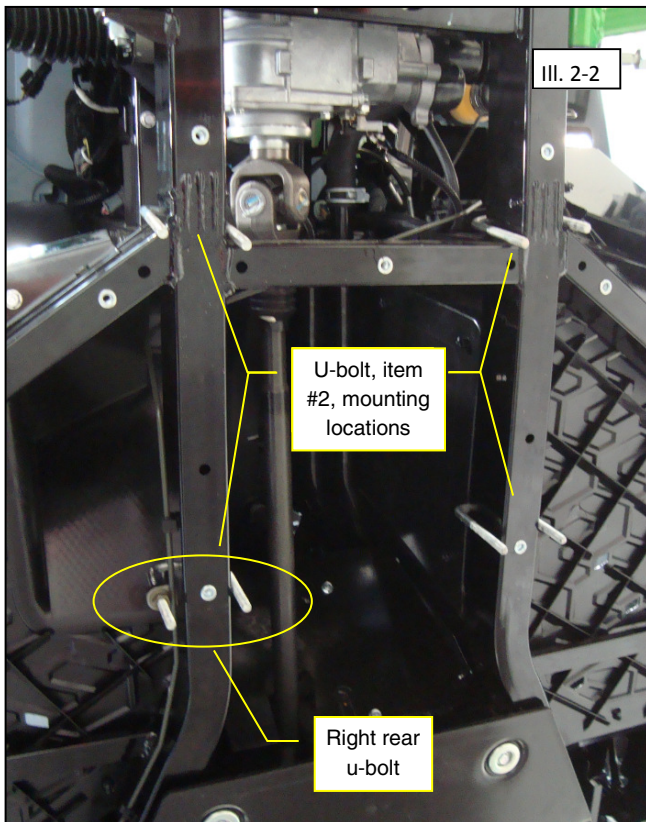
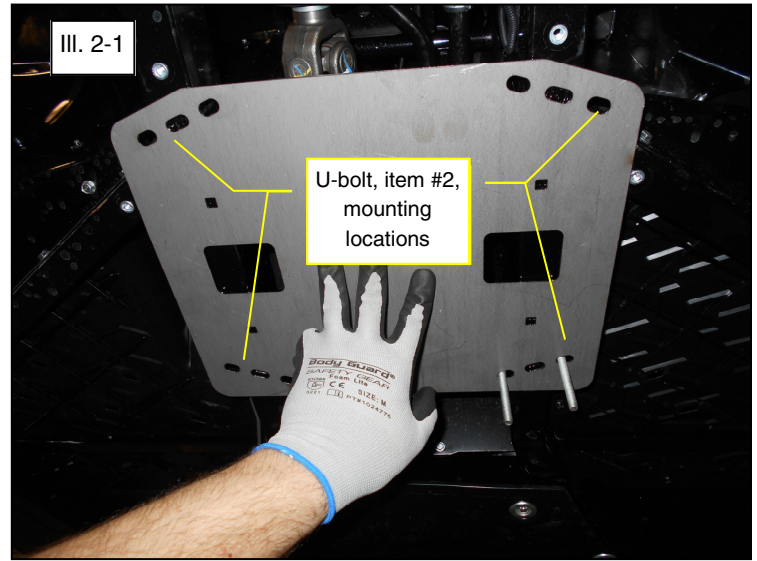

Teryx Mount Plate Installation (continued):

5. Re-install the plastic skid plates allowing the u-bolt hardware to fit thru the drilled holes.
6. Assemble the spacer Brackets (item #3) onto the U-bolts as shown. The spacer will fit in between the vehicle plastic skid plate and the mount plate (item #1). (See illustration 2-5).
7. Install the Teryx Mount Plate (item #1) onto the vehicle. The u-bolts (item #2) will fit thru holes in the plate as shown. Fasten the u-bolts with the M8 locknuts, item #4. Do not tighten at this step. (See illustration 2-6).
8. Insert the M8 carriage bolts (item #5) thru the plate as shown. (See illustration 2-6).
9. Tighten the M8 locknuts (item #4) for securing the u-bolts (item #2). Use caution to not overtighten u-bolts. Excessive bolt length can be trimmed from u-bolt (item #2), 3-4 threads past nut locking patch. (See illustration 2-6 and 2-7).
10. The universal mount plate, not included in kit, will be attached to the Teryx mount plate (item #1) as shown. The M8 carriage bolts will fasten the universal plate with M8 locknuts (item #4). Tighten to specification. (See illustration 2-7).
11. Re-install the OEM hardware for floorboard inside cab.

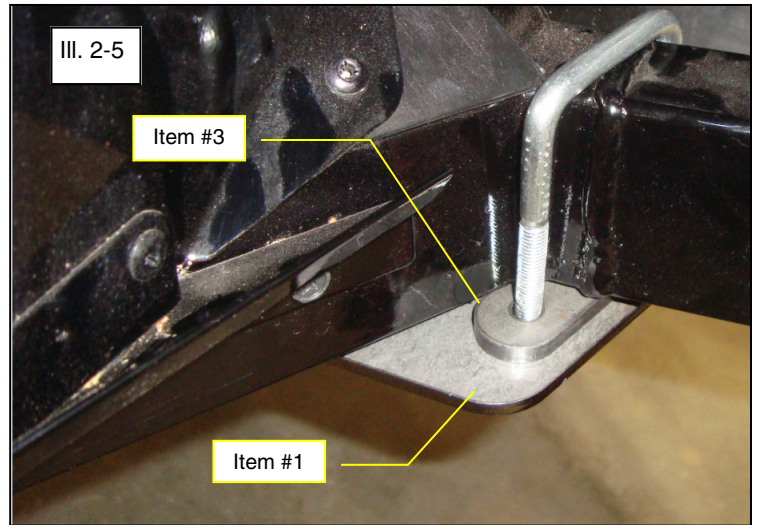

 = T
8MM FASTENER TORQUE: 17 ft. lbs. (23 Nm)

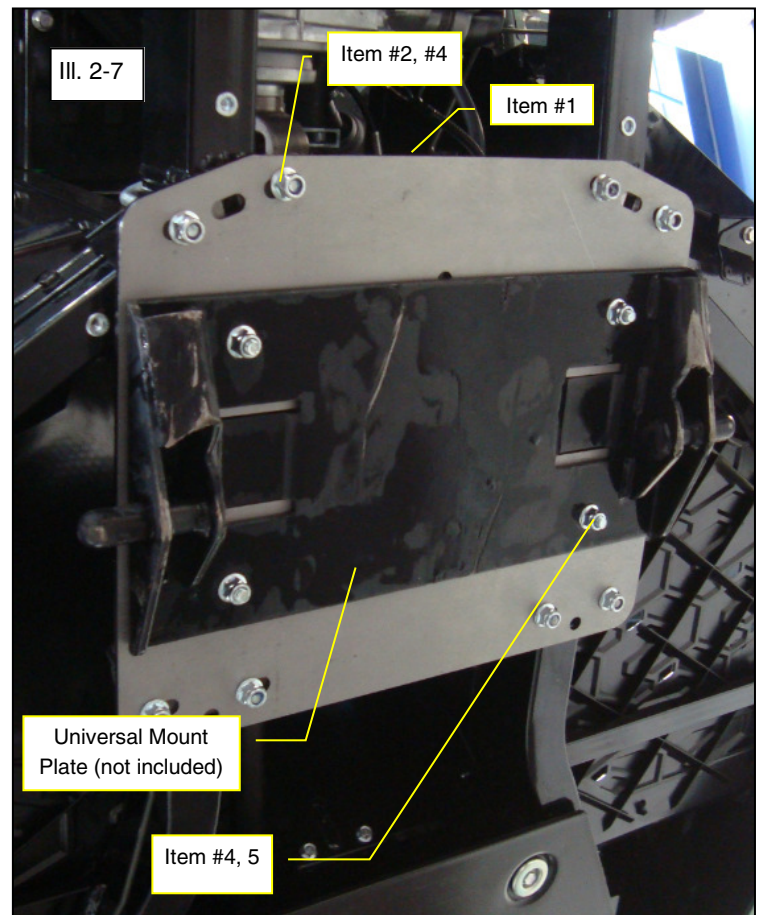
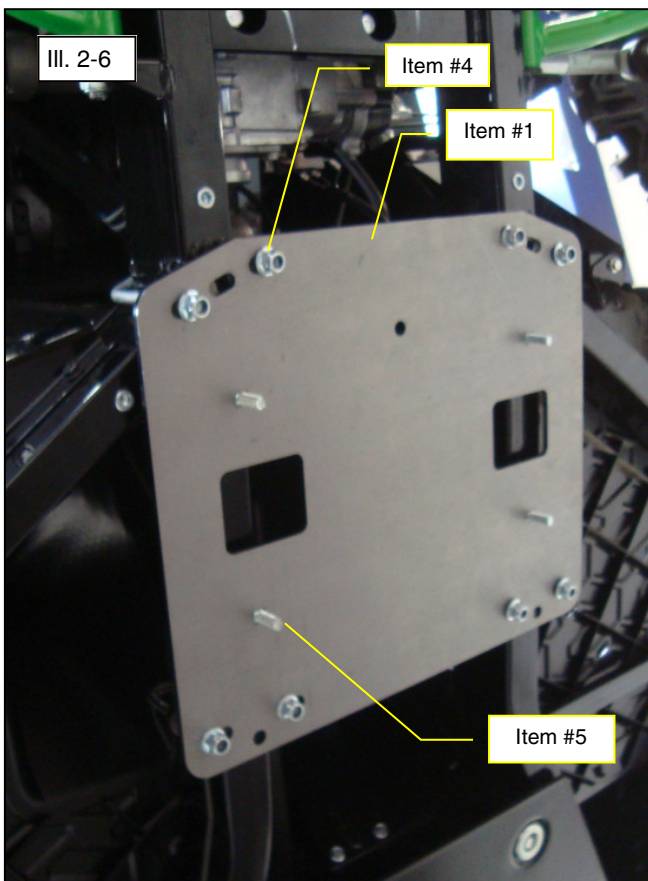

Rhino Installation Prep:

1. From under the vehicle, remove the plastic skid plate if equipped.
2. Use the mount plate (item #1) as a pattern to mark the hardware locations into the skid plate. Scribe or mark the Rhino u-bolt hole locations onto the thin metal skid plate as shown. Note, the following page includes a Rhino Drill Template that can be used to match vehicle skid plate and hole locations. **Note, the inner slotted holes are for the Teryx u-bolt mount pattern. The outer slotted holes are for the Rhino u-bolt mount pattern.** (See illustration 3-1).
3. Drill holes through the skid plates at locations marked. Use a 3/8" to 1/2" bit to create an over-sized hole that will allow some relief when installing hardware. **Note, a high speed cutting tool (like a Dremel) with a cutting bit will also work.**

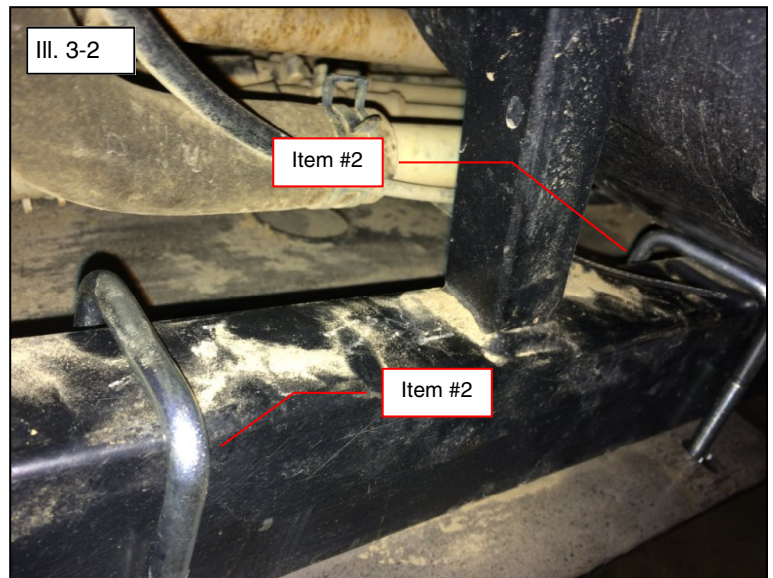
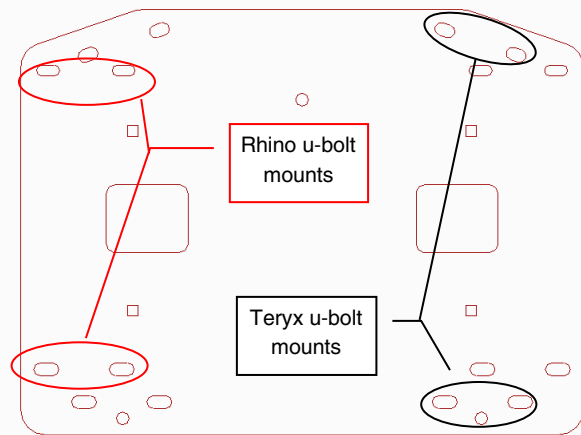
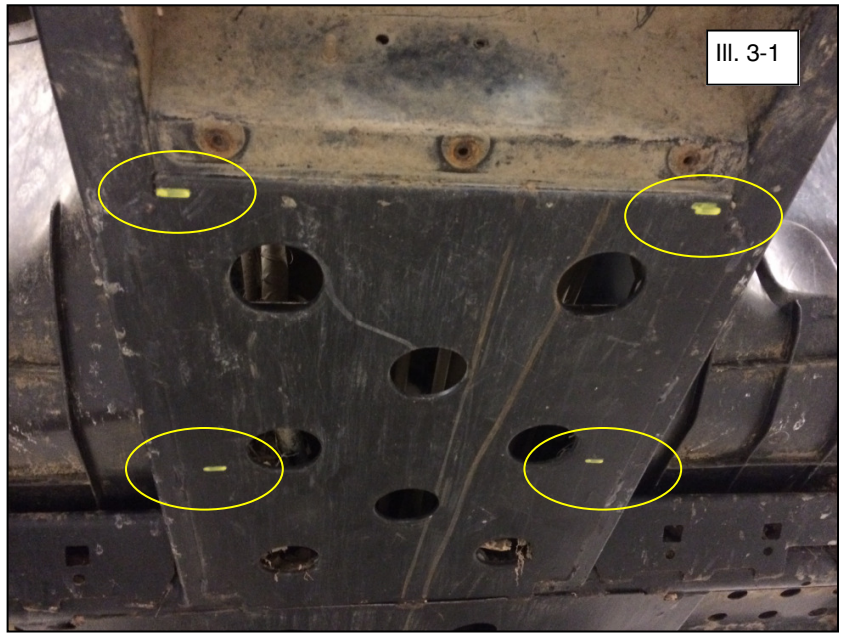

Rhino Mount Plate Installation:

1. Place the square u-bolts (item #2) around the frame locations and thru the drilled skid plate locations as shown. (See illustration 3-2).
2. Insert the M8 carriage bolts, item #5, thru the plate as shown. (See illustration 2-6).
3. Attach the mount plate (item #1) to the vehicle by placing onto u-bolts and fastening with locknuts (item #4) as shown.
4. Tighten to specification.
5. The universal mount plate, not included in kit, will be attached to the Rhino mount plate. (item #1).

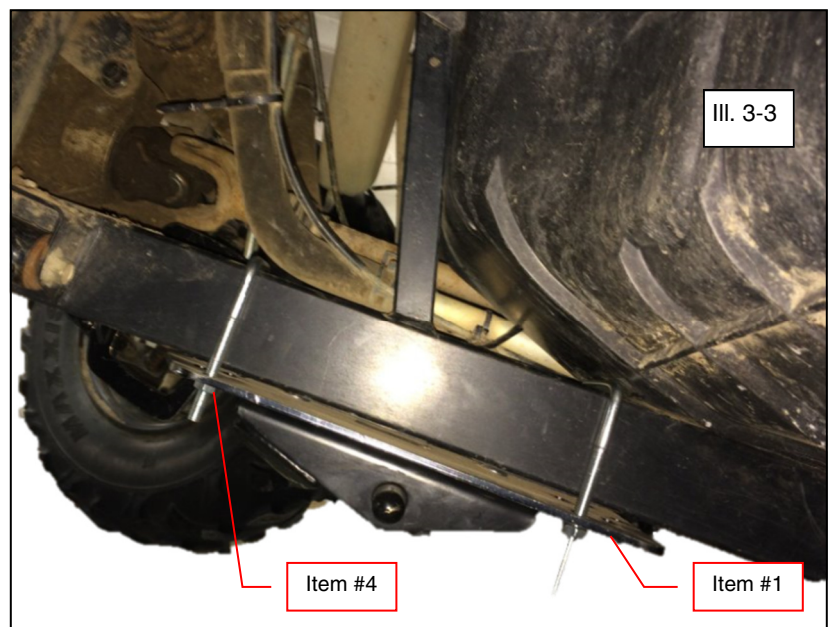

8MM FASTENER TORQUE: 17 ft. lbs. (23 Nm)

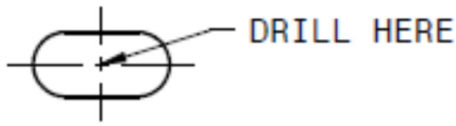

FRONT

THIS SIDE SHOULD ALIGN WITH THE EDGE OF THE FRAME

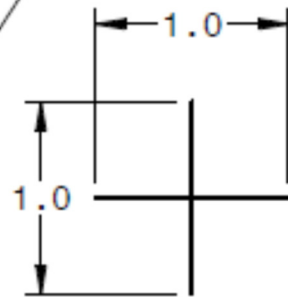
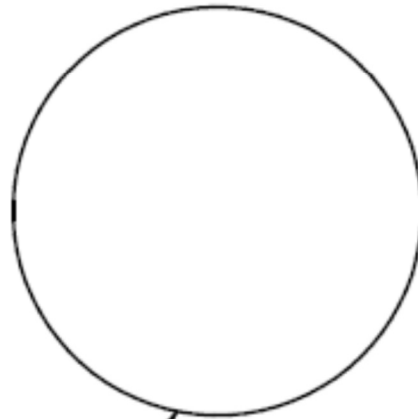

HOLES IN THE SKID PLATE

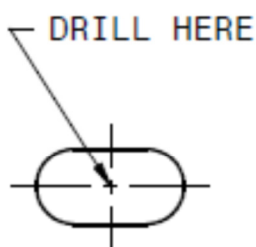
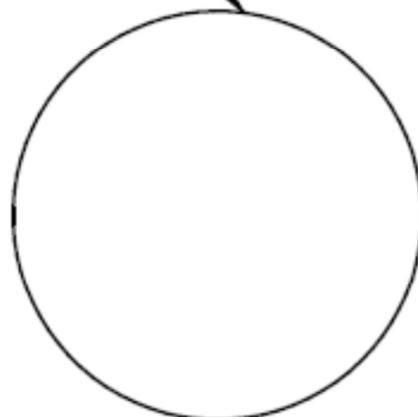

INSTRUCTIONS

1. Print this template on a 8.5"x11" sheet. It is important to print it without scaling or margins.

2. Measure the cross to validate the template is printed without scaling. The lines should measure 1" long.

3. Cut the 4 holes on the template.

4. Align the two big circles with the holes in the skid plate and mark the holes that should be drilled. Make sure the front arrow is pointing towards the front of the vehicle.

5. Drill the 2 holes.

6. Place the template on the other side of the vehicle and mark the 2 other holes. Drill the 2 last holes



One Year Limited Warranty

For the period of one (1) year from the purchase date, Kolpin will replace for the original purchaser, free of charge, any part or parts found upon examination by Kolpin to be defective in material, workmanship, or both.

All transportation costs incurred submitting product to Kolpin for warranty consideration must be borne by the purchaser. If Kolpin determines that the product must be returned to the factory for credit, please call 1-877-956-5746 for a Return Merchandise Authorization (RMA) number and shipping instructions.

This warranty does not apply to parts that have been damaged by accident, alteration, abuse, improper maintenance, normal wear, or other causes beyond the manufacturer's control. In order to protect you and your ATV, certain parts of the plow system and/or hardware are designed to fail when the equipment is over-stressed. Parts that are lost due to loosening and improper maintenance are not covered under warranty. This warranty does not cover removal or reinstallation labor fees of the plow system and related components.

Peripheral products such as engines, electric motors, and actuators may carry an original manufacturer's warranty. Most hardware is general in nature and is easily obtained locally. Be sure to replace with minimum metric class 8.8 specification.

Kolpin Outdoors, Inc.

Telephone: (763)-478-5800

Toll Free: (877)-956-5746

Fax Number: (800)-245-7569

www.kolpin.com

Email: customerservice@kolpin.com