

# CAN AM LINQ ANCHOR KIT

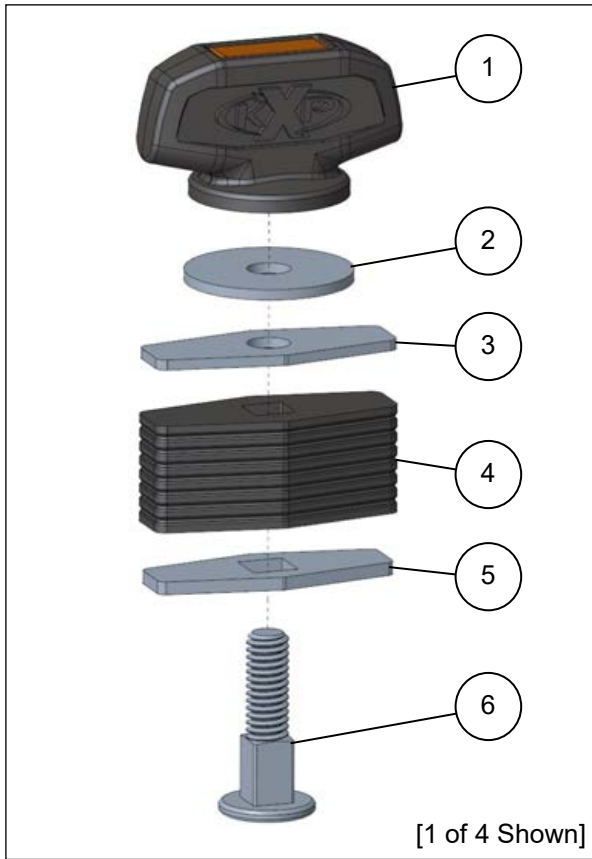

Product Instructions | Part No: 53503

## KIT CONTENTS



REF	QTY	PART DESCRIPTION
1	4	T-Knob
2	4	Washer
3	4	Upper Metal Bushing Plate
4	4	Rubber Bushing
5	4	Lower Metal Bushing Plate
6	4	Threaded Post

## BEFORE YOU BEGIN

- Verify all parts and tools are accounted for. If parts are missing, do not return to the store. Please contact Kolpin customer service department at (877) 956-5746 or (763) 478-5800 or email [customerservice@kolpin.com](mailto:customerservice@kolpin.com).
- Follow all steps correctly and in the sequence described.
- Keep these instructions for future reference or for informational requests.
- To facilitate installation, make sure that your vehicle is clean and free of debris.

## ACCESSORY MOUNTING INSTRUCTIONS

1. Remove T-Knob and Washer and insert Threaded Post into the mounting hole of the accessory being mounted. See Illustration 1-1.

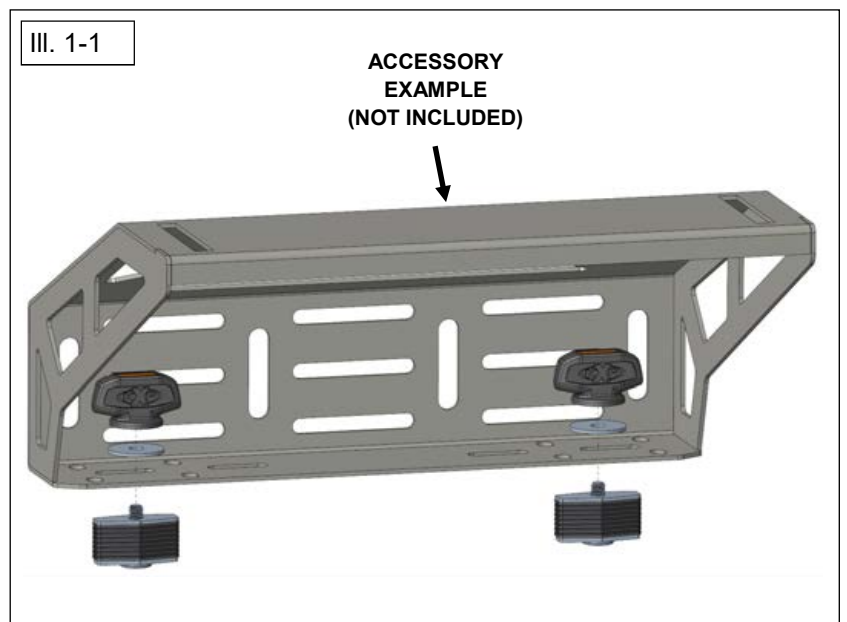

Kolpin Outdoors, Inc. | 9955 59th Ave N | Plymouth, MN 55442  
(877) 956-5746 or (763) 478-5800 | [kolpin.com](http://kolpin.com) | [customerservice@kolpin.com](mailto:customerservice@kolpin.com)

2. Lightly tighten the T-Knobs before inserting into the LinQ holes on your vehicle. Be sure Upper and Lower Metal Bushing Plates are aligned with the Rubber Bushing. See Illustration 1-2.



3. Insert into the LinQ holes on your vehicle. See Illustration 1-3.

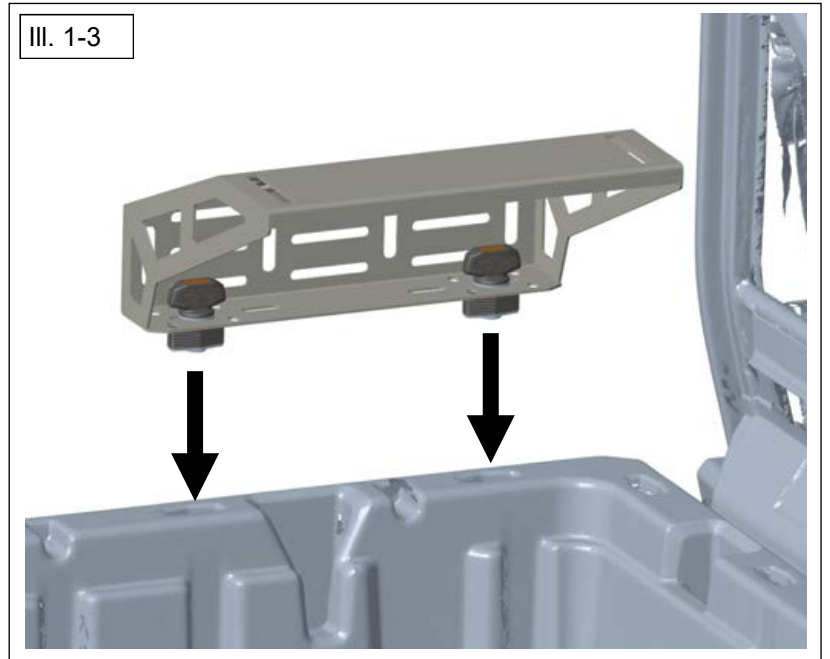

4. With accessory pressed evenly against LinQ holes on your vehicle, tighten the T-Knobs until they're firmly holding the accessory in place. See Illustration 1-4.

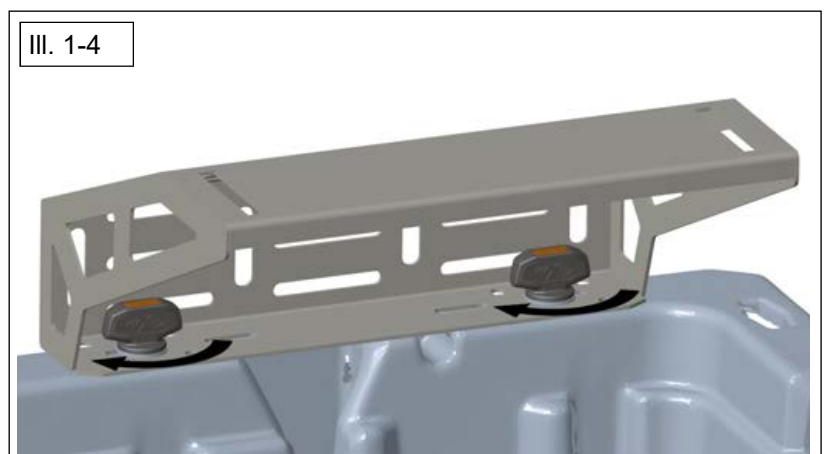

5. Once accessory is fully assembled, re-check and tighten T-Knobs as necessary.



## **USE AND CARE INFORMATION:**

- Check the accessory mounts frequently and retighten if necessary.
- When this accessory becomes dirty, rinse thoroughly with cool water to remove loose dirt, then wipe with a clean cloth or sponge.
- Never use petroleum solvents such as gasoline, thinner, benzene, acid or alkaline cleaners.

## **ONE YEAR LIMITED WARRANTY**

For the period of one (1) year from the purchase date, Kolpin will replace for the original purchaser, free of charge, any part or parts found upon examination by Kolpin to be defective in material, workmanship, or both.

All transportation costs incurred submitting product to Kolpin for warranty consideration must be borne by the purchaser. If Kolpin determines that the product must be returned to the factory for credit, please call 1-877-956-5746 for a Return Merchandise Authorization (RMA) number and shipping instructions.

This warranty does not apply to parts that have been damaged by accident, alteration, abuse, improper maintenance, normal wear, or other causes beyond the manufacturer's control. In order to protect you and your ATV, certain parts of the accessory system and/or hardware are designed to fail when the equipment is over-stressed. Parts that are lost due to loosening and improper maintenance are not covered under warranty. This warranty does not cover removal or reinstallation labor fees of the accessory system and related components. Most hardware is general in nature and is easily obtained locally. Be sure to replace with minimum metric class 8.8 specification.

**Kolpin Outdoors, Inc.**

**Telephone: (763)-478-5800**

**Toll Free: (877)-956-5746**

**Fax Number: (800)-245-7569**

**Email: [customerservice@kolpin.com](mailto:customerservice@kolpin.com)**

**[www.kolpin.com](http://www.kolpin.com)**

Can-Am®, LinQ®, and Defender® are registered trademarks of Bombardier Recreational Products Inc.,