

UTV Side & Rearview Mirrors-Landscape



Combo Kit

Product Instructions | Part No: 98327

Before you begin, read these instructions and check to be sure all parts and tools are accounted for. Please retain these installation instructions for future reference and parts ordering information. **Note: If any hardware is missing, do not return to the store. Call us to help, Toll Free 1-877-956-5746.**

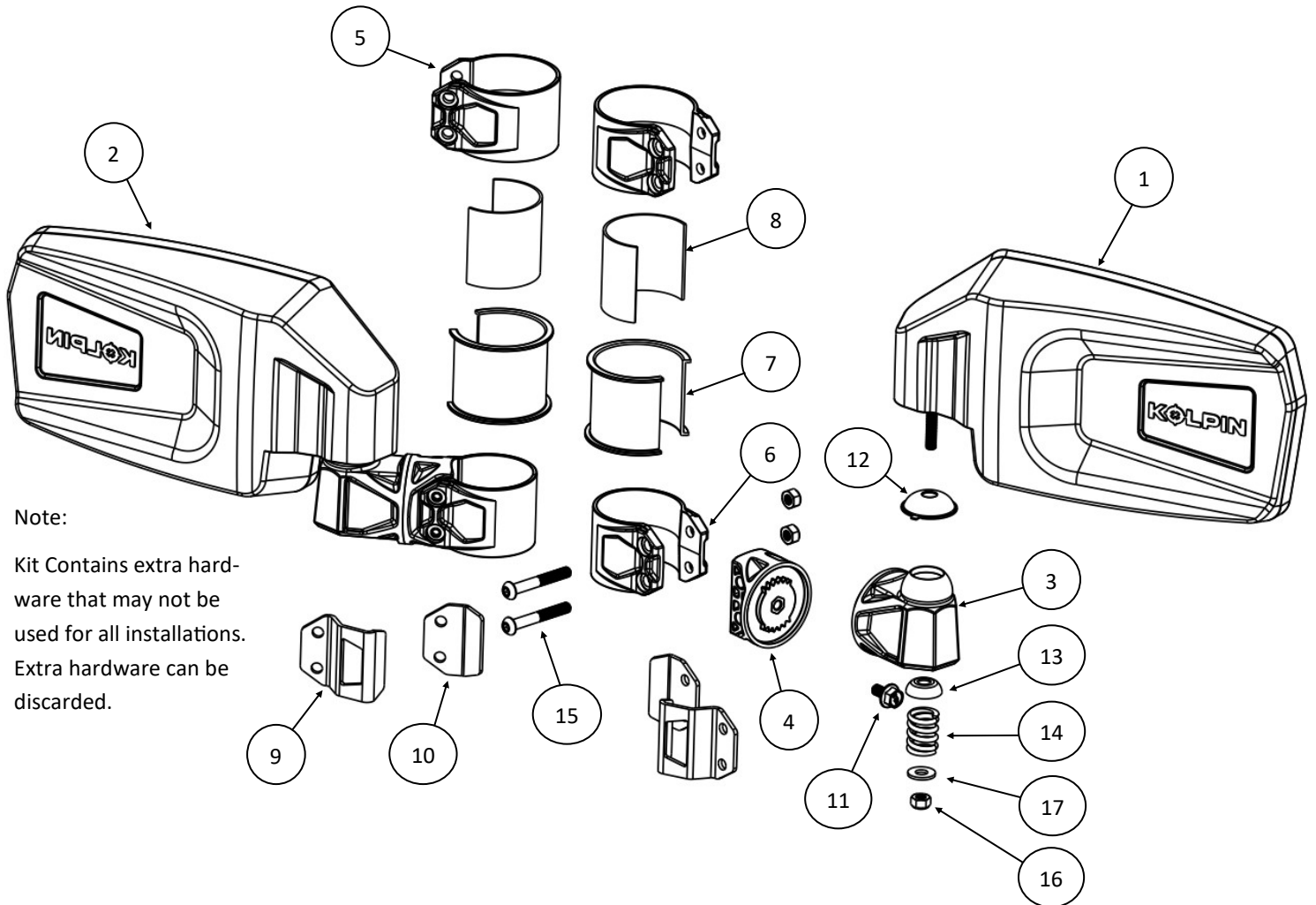

Note:

Kit Contains extra hardware that may not be used for all installations. Extra hardware can be discarded.

Side Mirror Kit contents:

Item	Qty	Part Description	Item	Qty	Part Description
1	1	Side Mirror Assembly, Left	10	2	Rear Metal Clamp
2	1	Side Mirror Assembly, Right	11	2	Flange Hex Screw, Zinc Plated, M6-1.0 x 12mm
3	2	Mirror Pivot Bracket	12	2	Large Domed Washer, Zinc Plated
4	2	Mirror Clamp Adapter	13	2	Small Domed Washer, Zinc Plated
5	2	1.75" OD Clamp	14	2	Compression Spring, Zinc Plated
6	2	2.0" OD Clamp	15	4	Button Screw, Zinc Plated, M6-1.0 x 45mm
7	2	U-Type Rubber Gripping Pad	16	6	Hex Locknut, Zinc Plated, M6-1.0
8	2	Flat Rubber Shim Pad	17	2	Fender Washer, Zinc Plated, M6
9	2	Front Metal Clamp			

Kolpin Outdoors, Inc. | 9955 59th Ave N | Plymouth, MN 55442

(877) 956-5746 or (763) 478-5800 | www.kolpin.com | customerservice@kolpin.com

These mirrors are designed to quickly and easily mount to any tubular bar, specifically UTV roll cages. The kits fit tubing sizes from 1-5/8" to 2" in diameter and profiled tubing found on Ranger and Defender vehicles. The clamp can be used in the vertical and horizontal positions. *Note, installation may be easier if certain items are removed from vehicle first.*

Side Mirror Install Preparation:

1. Remove the mirror assemblies from packaging. Verify that the mirrors are in good condition and that all the hardware is present. Items 1-4, 11-14 and 16-17 will be pre-assembled. The mirror kit includes extra clamps to fit various tube shapes/sizes and not all hardware will be used depending on application.
2. For installing onto 2.0" round tubing, use the 2.0 inch clamp (item #6) with the u-type rubber grip pad (item #7). The u-type gripping pad will be inserted between the clamp and vehicle tube to increase friction and dampen vibrations as shown. (See illustration 1-1). *Note, orientate the ends of the u-type pad (item #7) to allow the clamp adapter (item #4) to make contact with tube as shown. (See illustration 1-2).*
3. For installing onto 1.75" round tubing, use the 1.75 inch clamp (item #5) with the u-type rubber grip pad (item #7). The u-type gripping pad will be inserted between the clamp and vehicle tube to increase friction and dampen vibrations as shown. (See illustration 1-1). *Note, orientate the ends of the u-type pad (item #7) and shim (item #8) to allow the clamp adapter (item #4) to make contact with tube as shown. (See illustration 1-2).*
4. For installing onto 1-7/8" round tubing, use the 2.0 inch clamp (item #6) with the u-type rubber grip pad (item #7) and flat rubber shim (item #8). The u-type gripping pad will be inserted between the clamp and flat shim to increase friction and dampen vibrations as shown. The flat shim fits between u-type pad and vehicle tubing. (See illustration 1-2). *Note, the u-type shim will need to be trimmed to best fit 1.75" round tubing using a scissors or knife. Cut 1" of material from end of pad as shown. (See illustration 1-5). Note, orientate the ends of the u-type pad (item #7) to allow the clamp adapter (item #4) to make contact with tube as shown. (See illustration 1-2).*
5. For installing onto 1-5/8" round tubing, use the 1.75 inch clamp (item #5) with the u-type rubber grip pad (item #7) and flat rubber shim (item #8). The u-type gripping pad will be inserted between the clamp and flat shim to increase friction and dampen vibrations as shown. The flat shim fits between u-type pad and vehicle tubing. (See illustration 1-3). *Note, the both shims will need to be trimmed to best fit 1.63" round tubing using a scissors or knife. Cut 1" of material from end of pad as shown. (See illustration 1-5). Note, orientate the ends of the u-type pad (item #7) to allow the clamp adapter (item #4) to make contact with tube as shown. (See illustration 1-2).*
6. For Polaris Ranger and Can-Am Defender profiled tubing, use the front metal clamp (item #9) and rear metal clamp (item #10) as shown. (See illustrations 1-3 and 1-4).

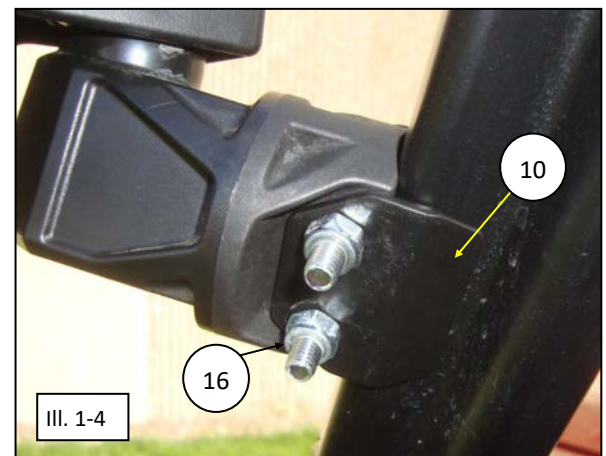
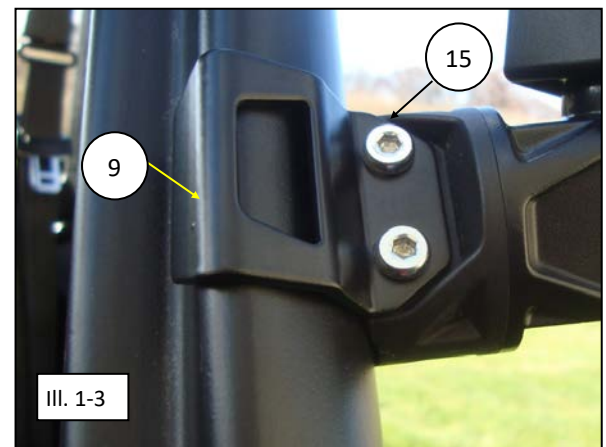
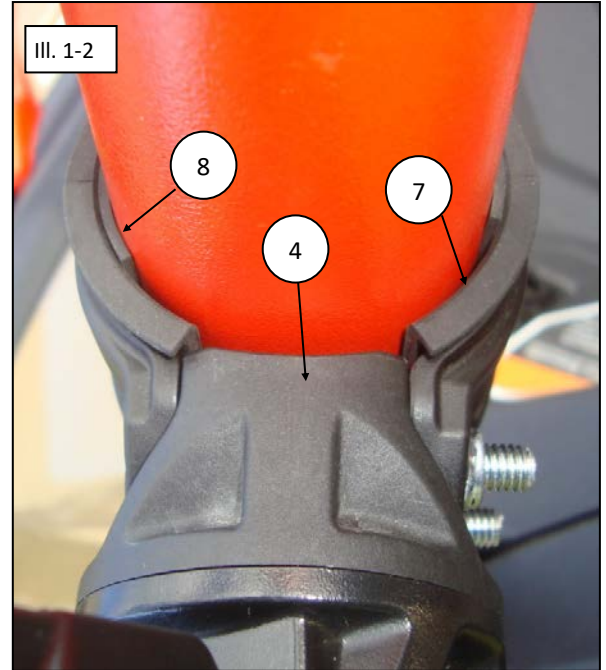
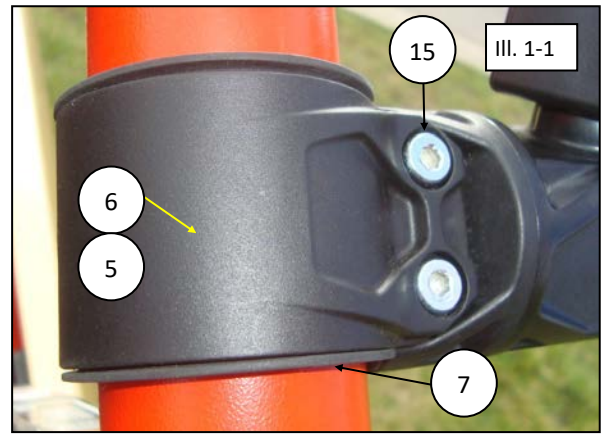

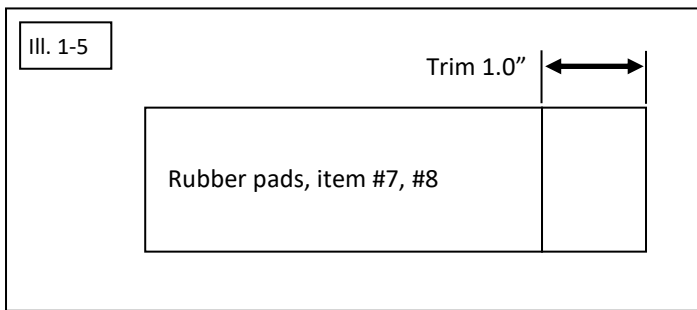

Tools and Supplies Required for Side Mirror Install:

- 5mm Hex Allen Wrench or Socket Bit
- 10mm Socket or 10mm Wrench
- Ratchet (if socket is used)
- Scissors or utility knife

Side Mirror Mounting Instructions:

1. Position and clamp the assembled mirror onto the left A-pillar in desired location. Use the two screws (item #15) and two locknuts (item #16) to secure clamp and mirror assembly into position.
2. Tighten the screws to specified torque setting.
3. Loosen (turn counter-clockwise) the M6 flange hex screw (item #11) using a 10mm box end wrench just enough to separate the mirror pivot (item #3) from the clamp adapter (item #4) as shown. (See illustration 1-6).
4. Pivot mirror to desired angle by rotating the pivot bracket and then tighten (turn clockwise) the M6 flange hex screw (item #11) to secure.
5. You can also rotate the mirror in and out to desired viewing angle. To increase the amount of force needed to rotate mirror, simply tighten (turn clockwise) the tensioning nut (item #16 - 8Nm MAX) two revolutions as shown. (See illustration 1-7).
6. Repeat steps 1-5 for installing the right side mirror onto the right A-pillar.

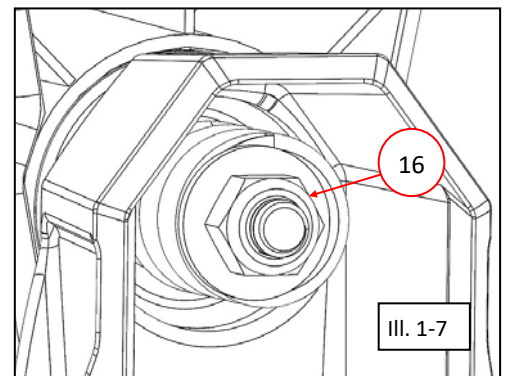
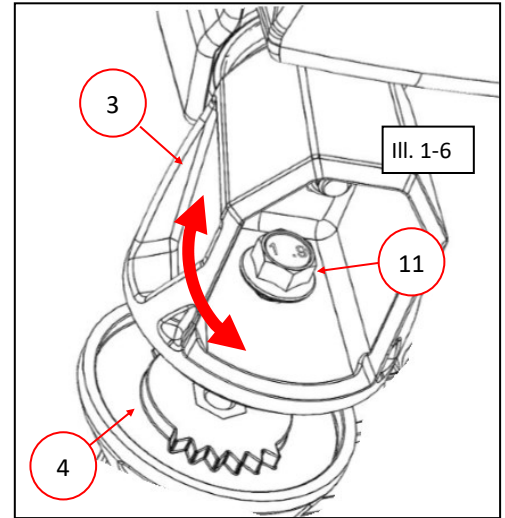

WARNING: Do not over tighten hardware or damage can occur.

Torque Charts: Tighten all screws to their specified torque values listed.

Item	N*m	kgf*m	lbf*ft
11	1.4	0.1	1
15	5	0.5	4

Side Mirror Use and Care Information:

- Check the accessory mounts frequently and retighten if necessary.
- Replace this accessory with a new one if it is damaged or discolored excessively.
- When this accessory becomes dirty, rinse it thoroughly with cool water to remove loose dirt, then wipe with a clean cloth or sponge.
- Never use petroleum solvents such as gasoline, thinner, benzene, acid or alkaline cleaners.
- Side mirrors are not intended for on-road use.

SIDE MIRROR SPARE KITS		Hardware & clamp kit P/N: 98316
Item	Description	
5	1.75" OD Clamp	1x
6	2.0" OD Clamp	1x
7	U-Type Rubber Gripping Pad	1x
8	Flat Rubber Shim Pad	1x
9	Front Metal Clamp	1x
10	Rear Metal Clamp	1x
11	Flange Hex Screw, Zinc Plated, M6-1.0 x 12mm	1x
12	Large Domed Washer, Zinc Plated	1x
13	Small Domed Washer, Zinc Plated	1x
14	Compression Spring, Zinc Plated	1x
15	Button Screw, Zinc Plated, M6-1.0 x 45mm	2x
16	Hex Locknut, Zinc Plated, M6-1.0	3x
17	Fender Washer, Zinc Plated, M6	1x

For additional assistance, please contact Kolpin technical service department at (877) 956-5746 or (763) 478-5800 or email customerservice@kolpin.com

Rearview Mirror Kit contents:

Item	Qty	Part Description
1	1	Rearview Mirror Assembly, Center
2	1	Threaded Ball Stud
3	2	Tube Clamp Adapter
4	2	Button Screw, Zinc Plated, M6-1.0 x 45mm
5	1	2.0" OD Clamp
6	2	Hex Locknut, Zinc Plated, M6-1.0
7	1	1.75" OD Clamp
8	1	U-Type Rubber Gripping Pad
9	1	Flat Rubber Shim Pad

This rearview mirror is designed to quickly and easily universal mount to any tubular bar, specifically UTV roll cages. The kit fits tubing sizes from 1-5/8" to 2.0" in diameter. The clamp can be used in the vertical and horizontal positions. The ball joint is easy to adjust and increases viewing positions. *Note, installation may be easier if certain items are removed from vehicle first.*

- Tools and Supplies Required for Rearview Mirror Install:**
- 5mm Hex Allen Wrench or Socket Bit
 - Ratchet (if socket is used)
 - Scissors or utility knife

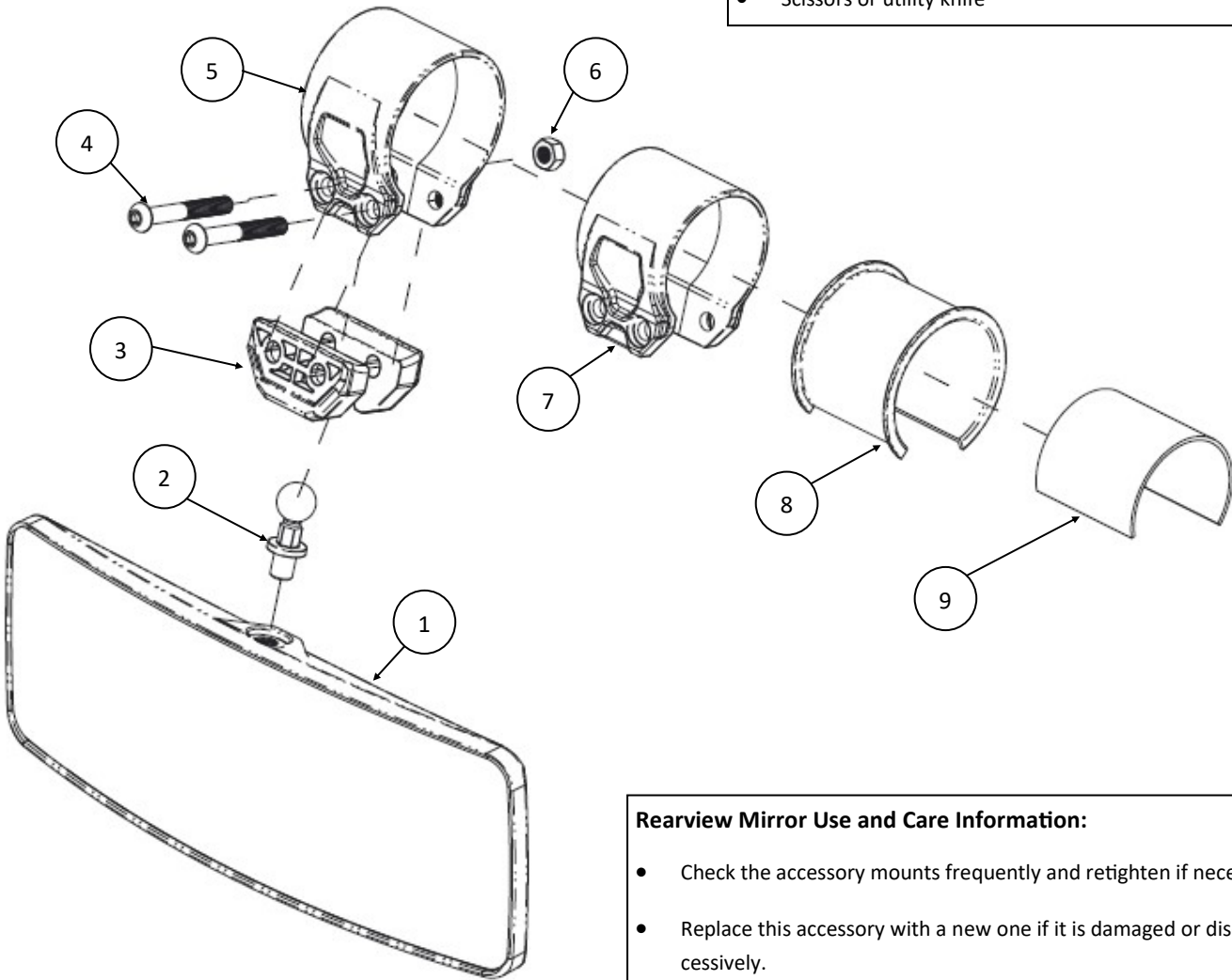

Note:

Kit Contains extra hardware that may not be used for all installations. Extra hardware can be discarded.

- Rearview Mirror Use and Care Information:**
- Check the accessory mounts frequently and retighten if necessary.
 - Replace this accessory with a new one if it is damaged or discolored excessively.
 - When this accessory becomes dirty, rinse it thoroughly with cool water to remove loose dirt, then wipe with a clean cloth or sponge. Never use petroleum solvents such as gasoline, thinner, benzene, acid or alkaline cleaners.
 - Rearview mirror is not intended for on-road use.

Rearview Mirror Install Preparation:

1. Remove the mirror assemblies from packaging. Verify that the mirror is in good condition and that all the hardware is present. Items 1-2 will be pre-assembled. The mirror kit includes extra clamps to fit various tube sizes and not all hardware will be used depending on application.
2. For installing onto 2.0" round tubing, use the 2.0 inch clamp (item #5) with the u-type rubber grip pad (item #8). The u-type gripping pad will be inserted between the clamp and vehicle tube to increase friction and dampen vibrations as shown. (See illustration 2-1). *Note, orientate the ends of the u-type pad (item #8) to allow the clamp adapters (item #3) to make contact with tube as shown.*
3. For installing onto 1.75" round tubing, use the 1.75 inch clamp (item #7) with the u-type rubber grip pad (item #8). The u-type gripping pad will be inserted between the clamp and vehicle tube to increase friction and dampen vibrations as shown. (See illustration 2-1). *Note, orientate the ends of the u-type pad (item #8) to allow the clamp adapter (item #3) to make contact with tube as shown. Note, the u-type shim will need to be trimmed to best fit 1.75" round tubing using a scissors or knife. Cut 1" of material from end of pad as shown. (See illustration 2-3).*
4. For installing onto 1-7/8" round tubing, use the 2.0 inch clamp (item #5) with the u-type rubber grip pad (item #8) and flat rubber shim (item #9). The u-type gripping pad will be inserted between the clamp and flat shim to increase friction and dampen vibrations as shown. The flat shim fits between u-type pad and vehicle tubing. (See illustration 2-2). *Note, orientate the ends of the u-type pad (item #8) and shim (item #9) to allow the clamp adapters (item #3) to make contact with tube as shown. (See illustration 2-2).*
5. For installing onto 1-5/8" round tubing, use the 1.75 inch clamp (item #7) with the u-type rubber grip pad (item #8) and flat rubber shim (item #9). The u-type gripping pad will be inserted between the clamp and flat shim to increase friction and dampen vibrations as shown. The flat shim fits between u-type pad and vehicle tubing. (See illustration 2-2). *Note, the both shims will need to be trimmed to best fit 1.63" round tubing using a scissors or knife. Cut 1" of material from end of pad as shown. (See illustration 2-3). Note, orientate the ends of the u-type pad (item #8) and shim (item #9) to allow the clamp adapters (item #3) to make contact with tube as shown. (See illustration 2-2).*

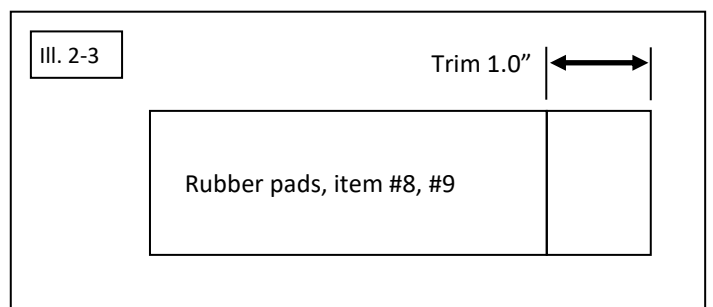
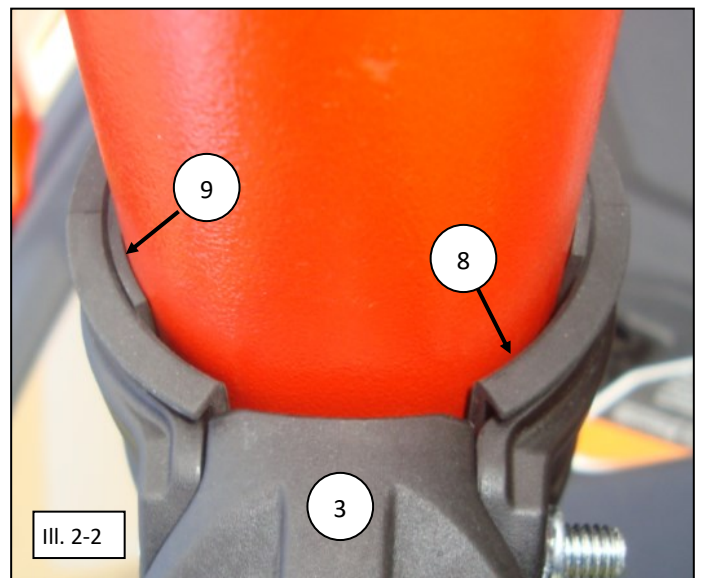
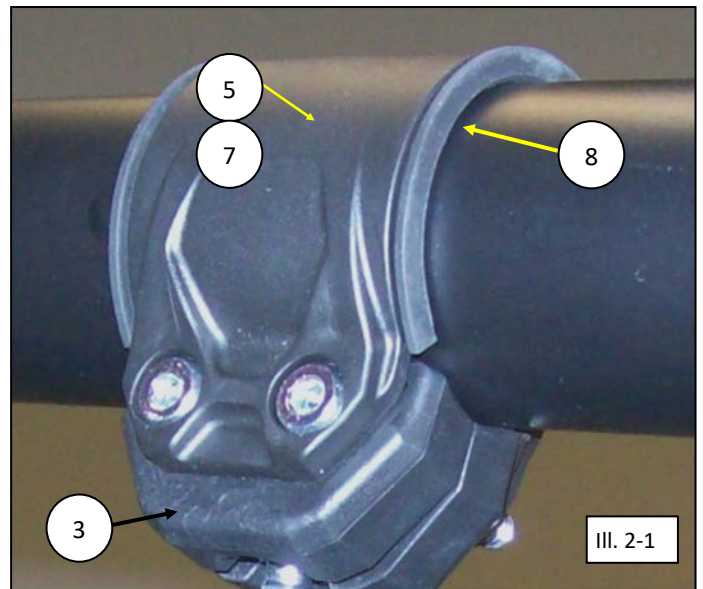

Rearview Mirror Mounting Instructions:

1. For your specific vehicle configuration listed on page 5, position - clamp and fasten the assembled mirror onto the vehicle in desired location. The clamp adapters (item #3) have a socket receptacle to hold the ball stud (item #2). Insert the mirror assembly into the clamp adapters as shown. Use the two screws (item #4) and two locknuts (item #6) to secure the clamp and mirror assembly into position. (See illustrations 3-1 and 3-2).
2. Tighten the screws to specified torque setting. **WARNING:** Do not over tighten hardware or damage can occur.

Torque Charts: Tighten all screws to their specified torque values listed in below table.

Item	N*m	kgf*m	lbf*ft
4	5	0.5	4

3. Pivot mirror to desired viewing angle by loosening (turn counter-clockwise) the screws (item #4) and then tighten (turn clockwise) to secure into position. *Note, if the screws (item #4) are loosened too much, the clamp adapters (item #3) can allow mirror (item #1) to become disconnected from the clamp assembly - please support mirror while making adjustments.*

For additional assistance, please contact Kolpin technical service department at (877) 956-5746 or (763) 478-5800 or email customerservice@kolpin.com

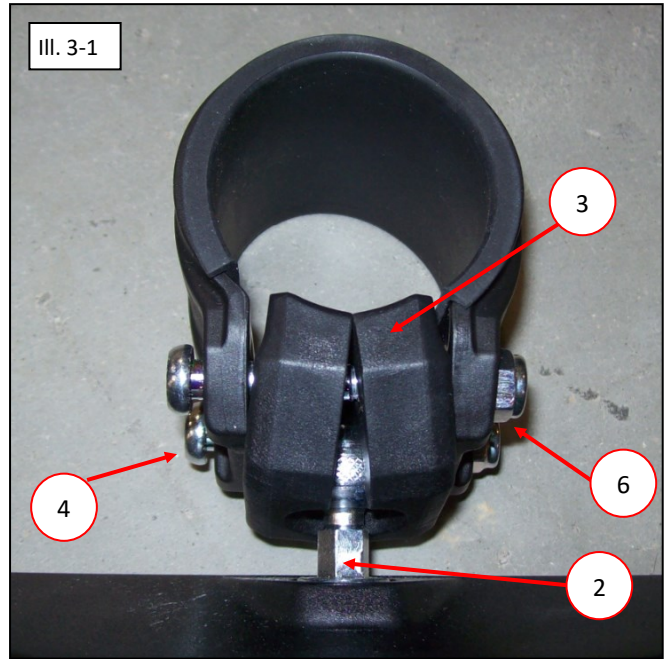

REARVIEW MIRROR SPARE KITS		Hardware & clamp kit P/N: 98316
Item	Description	
4	Button Screw, Zinc Plated, M6-1.0 x 45mm	2x
5	2.0" OD Clamp	1x
6	Hex Locknut, Zinc Plated, M6-1.0	3x
7	1.75" OD Clamp	1x
8	U-Type Rubber Gripping Pad	1x
9	Flat Rubber Shim Pad	1x

Spare kit contains extra hardware that is used for other mirror kits. Extra hardware can be discarded.

One Year Limited Warranty

For the period of one (1) year from the purchase date, Kolpin will replace for the original purchaser, free of charge, any part or parts found upon examination by Kolpin to be defective in material, workmanship, or both.

All transportation costs incurred submitting product to Kolpin for warranty consideration must be borne by the purchaser. If Kolpin determines that the product must be returned to the factory for credit, please call 1-877-956-5746 for a Return Merchandise Authorization (RMA) number and shipping instructions.

This warranty does not apply to parts that have been damaged by accident, alteration, abuse, improper maintenance, normal wear, or other causes beyond the manufacturer's control. In order to protect you and your ATV, certain parts of the accessory system and/or hardware are designed to fail when the equipment is over-stressed. Parts that are lost due to loosening and improper maintenance are not covered under warranty. This warranty does not cover removal or reinstallation labor fees of the plow system and related components.

Peripheral products such as engines, electric motors, and actuators may carry an original manufacturer's warranty. Most hardware is general in nature and is easily obtained locally. Be sure to replace with minimum metric class 8.8 specification.