

ENGINE - 570

ENGINE OIL LEVEL - 570

Access the oil dipstick and fill tube from the right side of the vehicle. A rising oil level between checks in cool weather driving can indicate contaminants such as gas or moisture collecting in the crankcase. If the oil level is over the full/safe mark, change the oil immediately.

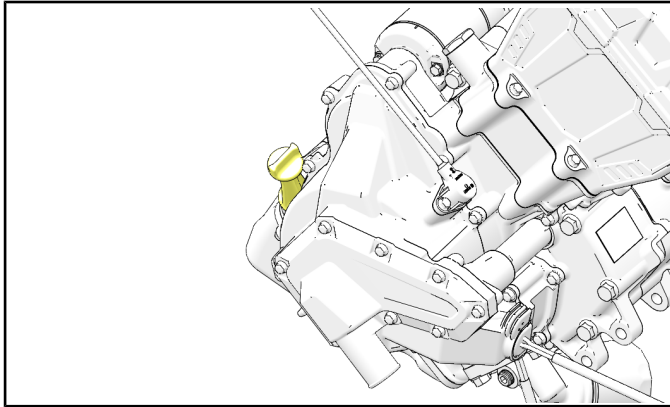

1. Set machine on a level surface.
2. Clean the area around the dip stick.
3. Remove dipstick and wipe dry with a clean cloth.
4. Reinstall dipstick completely.

NOTE

The dipstick must be screwed completely in to ensure accurate measurement.

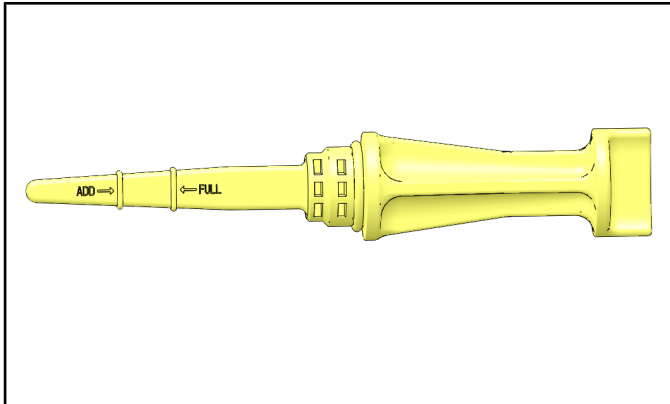

5. Remove dipstick and check the oil level. The oil level should be between the top line and the bottom line on the dipstick. Add oil as indicated by the level on the dipstick. Do not overfill.

NOTE

Rising oil level between checks in cool weather driving, can indicate moisture collecting in the oil reservoir. If the oil level is over the full mark, change the oil.

MAINTENANCE

OIL AND FILTER CHANGE - 570

Always change the oil and filter at the intervals outlined in the Periodic Maintenance Chart. Always change the oil filter whenever changing oil.

Oil Filter torque:
Turn by hand until filter gasket contacts sealing surface, then turn an additional 3/4 turn

Oil Filter Wrench:
PU-50105

Recommended Engine Oil:
Polaris PS-4
Synthetic 5W-50

CAUTION

Personal injury can occur when handling used oil. Hot oil can cause burns or skin damage.

NOTICE: Care must be taken to ensure that the fluids are contained. Be prepared to collect the fluid with suitable containers before opening any compartment or disassembly of any component containing fluids.

1. Place vehicle on a level surface.
2. Place the transmission in PARK (P).
3. Clean area around drain plug at bottom of oil pan.
4. Start the engine. Allow it to warm up at idle for two to three minutes.
5. Stop the engine.
6. Place a drain pan under the crank case.
7. Remove the drain plug ①. Allow oil to drain completely.

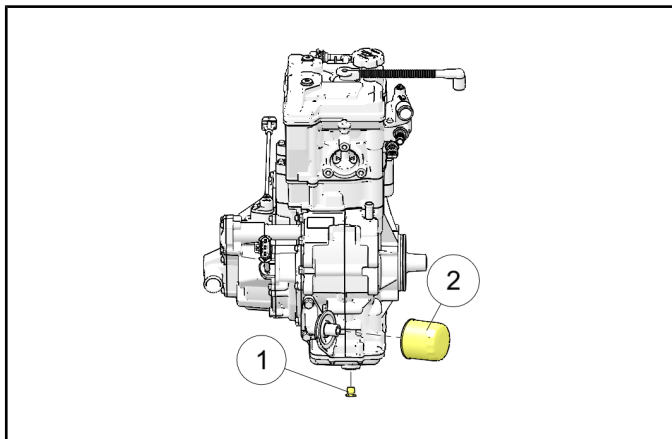

8. Replace sealing washer on drain plug.

NOTE

The sealing surfaces on the drain plug and the oil tank should be clean and free of burrs, nicks or scratches.

9. Reinstall the drain plug and torque it to specification.

TORQUE

Oil Pan Drain Plug:
12 ft-lbs (16 Nm)

10. Place a drain pan under the oil filter.
11. Place shop towels beneath oil filter ②. Use Oil Filter Wrench (**PU-50105**), turn filter counterclockwise to remove.
12. Using a clean dry cloth, clean filter sealing surface on the crankcase.
13. Lubricate the o-ring on new filter with a thin film of engine oil. Check to make sure the O-ring is in good condition.
14. Install the new filter and turn it by hand until the filter gasket contacts the sealing surface, then turn an additional 3/4 of a turn.
15. Remove dipstick.
16. Add oil as necessary to bring the oil level to the upper mark on the dipstick. Do not over fill the engine, the maximum oil capacity is 2 qts(1.9 l).

NOTE

The dipstick must be screwed completely in to ensure accurate measurement.

17. Reinstall the upper fill cap (if removed) and tighten the dipstick.
18. Place the transmission in PARK (P).
19. Verify that the transmission is still positioned in PARK (P).
20. Start the engine. Allow it to idle for two minutes.
21. Stop the engine and check for leaks.
22. Check the oil level on the dipstick and add oil as necessary to bring the level to the upper mark on the dipstick.
23. Dispose of used filter and oil properly.