



# OIL CHANGE KIT KIT PN 2873551

## Application

All Victory Models

THE NEW AMERICAN MOTORCYCLE™

Before you begin, it is very important that you read and understand these instructions. Make sure you follow them exactly. Make certain all parts and tools are accounted for. Please retain these installation instructions for future reference and parts ordering information.

<u>Qty.</u>	<u>Part Description</u>	<u>Part No.</u>
6*	Victory Engine Oil, Qt., Synthetic Blend	2872175
<b>*NOTE: Oil capacity varies by model. Refer to Owner's Manual or Service Manual for engine oil capacity. Do not over-fill.</b>		
1	Oil Filter (All Models)	2540086
1	Washer, Drain Plug (1999-2000)	7556039
1	O-Ring, Drain Plug (2001-2002)	5412020
1	Washer, Drain Plug (2003-Current)	5812232
1	Instruction	9916735

You will need to supply:

Oil Filter Wrench

14mm Allen Wrench **(1999-2001)**

3/8 Square Drive Breaker Bar or equivalent **(2002)**

6mm Allen Wrench **(2003-Current)**

Torque Wrench

Oil Drain Pan

Shop Cloth

## WARNING

The engine and exhaust system become very hot during operation and remains hot for a period of time after the engine is shut off. Wear insulated protection for hands and arms or wait until the engine and exhaust system have cooled before working on the machine.

## WARNING

**CARBON MONOXIDE** Never run an engine in an enclosed area. Exhaust contains poisonous carbon monoxide gas that can cause loss of consciousness and may lead to death. If you must run the engine to do some repairs, do so in an open area or with an exhaust evacuation system connected and functioning properly.

## WARNING

The engine exhaust from this product contains chemicals known to cause cancer, birth defects or other reproductive harm.

## CAUTION

Do not put in any chemical additives. Victory's motorcycle oil has been specifically designed for this application and any additional additives are not necessary and have not been tested by Victory. Do not allow foreign material to enter the crankcase.

**NOTE:** Make certain motorcycle kick stand is stabilized on a flat surface.

**IMPORTANT:** Perform all items correctly and completely.

1. Warm up the engine for several minutes.
2. Stop the engine. Securely support the machine on its sidestand. **IMPORTANT:** Take the proper precautions so the machine does not tip while working on it. Place an oil pan under the engine and loosen the oil fill cap / dipstick.

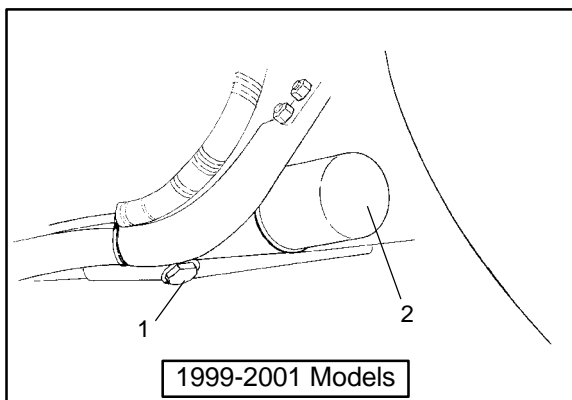

3. Remove the drain plug (1) and drain the oil.
4. Remove the oil filter (2).
5. Reinstall the drain plug with a new sealing washer or O-ring from the kit. Torque drain plug to the specification listed in the Owner's Manual or Service Manual.

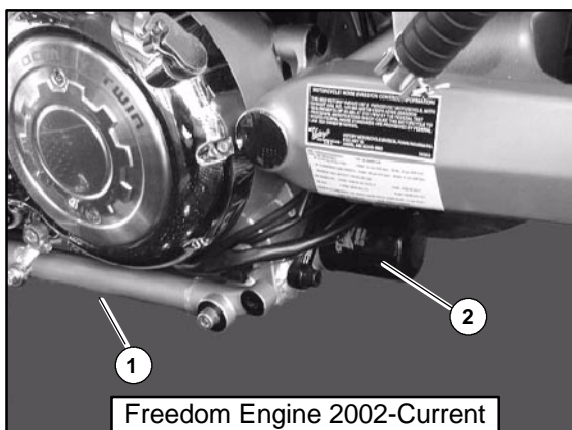

6. Apply a light coat of engine oil to the O-ring of the new oil filter. Make sure the O-ring is seated properly in the groove on the filter.

7. Install filter and tighten it 3/4 of a turn after O-ring contacts engine case.
8. Remove the fill cap / dipstick and fill the engine with the amount of oil recommended in the Owner's Manual or Service Manual and reinstall the dipstick / filler cap.
9. Start the engine and warm it up for several minutes and check for leaks. If any leaks are found, stop the engine and determine the source of the problem before starting the engine again. Contact your Victory dealer if you cannot determine the source of the leak.

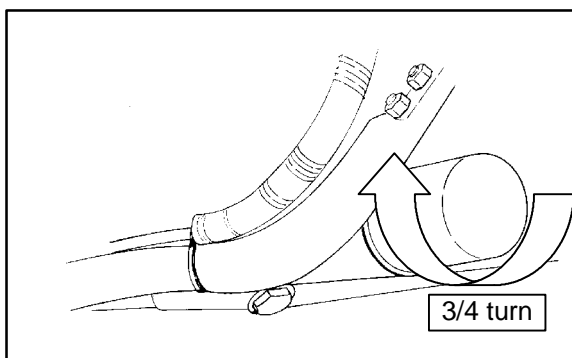

**NOTE:** After the engine is started, the oil indicator light should go off. If the indicator light flickers or remains on, immediately stop the engine and take your motorcycle to a Victory dealer.

10. Stop the engine and inspect oil level (refer to the Owner's Manual or Service Manual).
11. Install the fill cap / dipstick and tighten securely.

PN 9916735 Rev 03 7/05

Printed in U.S.A.