

MAINTENANCE PARTS & FLUIDS

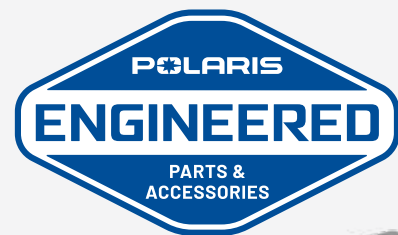

POLARIS ENGINEERED PARTS AND OIL

have been validated and tested extensively, specifically for your vehicle. In order to maintain the peak performance of your Polaris vehicle only use official Polaris Engineered parts and oil.



We're taking the passion of our riders, workers, and outdoor enthusiasts to the next level with HD Parts. These Heavy Duty parts are engineered for riders who want greater durability and enhanced performance. HD Parts are designed and tested to handle greater wear and tear under all weather conditions.

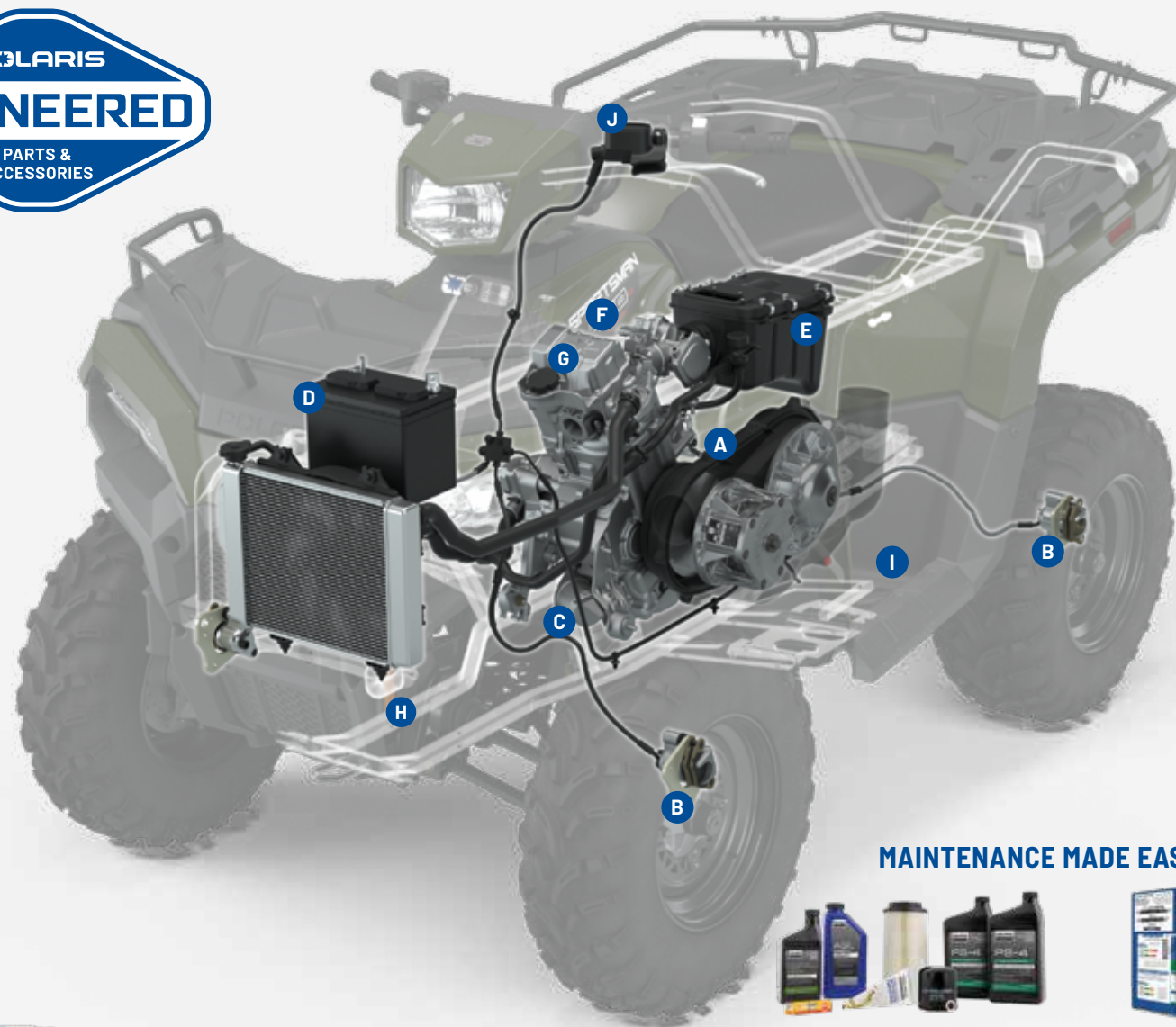

A DRIVE BELT

- » 3211113
450, 570
- » **HD** • 3212360
450, 570
- » 3211229
450 EPS (UTILITY), 570 EPS (PREMIUM, TRAIL), 570 TOURING, 570 X2, 570 6X6



B BRAKE PADS

- » FRONT & REAR • 2205606
450, 450 EPS (UTILITY), 570, 570 EPS (PREMIUM TRAIL)
- » **HD** FRONT • 2208934
570 TOURING, 570 X2, 570 6X6
- » **HD** REAR • 2208935
570 TOURING, 570 X2, 570 6X6
- » FRONT • 2202413
570 TOURING, 570 X2, 570 6X6
- » REAR • 2202412
570 TOURING, 570 X2, 570 6X6



C OIL FILTER

- » 2520799
- » **HD** • 2522485



D BATTERY

- » 4017419



E AIR FILTER

- » 7082101
- » **HD** • 7083114



F SPARK PLUGS

- » 450 • 3024016
- » 570 • 3022662

LOOKING FOR MORE SERVICE PARTS?

See P. 69 to learn how to find parts for your model.



G ENGINE OIL P. 64

- » PS-4 • 1QT • 2876244
- » PS-4 • 1GAL. • 2876245
- » PS-4 EXTREME • 1QT • 2889395
- » PS-4 EXTREME • 1GAL. • 2889396



H DEMAND DRIVE FLUID

- For front gearcase
- » 1QT • 2877922
- » 2.5 GAL. • 2877923



I AGI

- For transmission
- » 1QT • 2878068
- » 1GAL. • 2878069
- » EXTREME • 1QT • 2891028



J DOT 4 BRAKE FLUID

- » 12 OZ. • 2872189



ORV MAINTENANCE KIT

- Includes Oil Change Kit, Gearcase Fluids, Air Filter, & Spark Plug
- » 2830549
570 14-25



OIL CHANGE KITS

- 2 QT Engine Oil (oil varies by kit), 1 Oil Filter (2540086) & 1 Drain Plug Washer
- » PS-4 • 2877473
- » PS-4 EXTREME • 2890055



ALL-SEASON GREASE TUBE

- » 3 OZ. • 2871322
- » 14 OZ. • 2871423

MAINTENANCE SCHEDULE*

BREAK-IN MAINTENANCE

FIRST 25 HRS | 500 MI / 800 KM

- ENGINE OIL & OIL FILTER CHANGE
- FRONT GEARCASE CHANGE FLUID
- BRAKE PADS INSPECT
REPLACE AS NEEDED
- BRAKE FLUID INSPECT
ADD AS NEEDED
- TRANSMISSION INSPECT FLUID
ADD AS NEEDED

12 MONTHS

100 HRS | 1,000 MI / 1,600 KM

- ENGINE OIL & OIL FILTER CHANGE
- AIR FILTER INSPECT
REPLACE AS NEEDED
- BATTERY TEST & CLEAN
REPLACE AS NEEDED
- BRAKE PADS INSPECT
REPLACE AS NEEDED
- DRIVE BELT INSPECT
REPLACE AS NEEDED
- FRONT GEARCASE INSPECT
- GENERAL LUBRICATION ALL FITTINGS, PIVOTS, CABLES, ETC.
- TRANSMISSION FLUID INSPECT

24 MONTHS

200 HRS | 2,000 MI / 3,200 KM

- ENGINE OIL & OIL FILTER CHANGE
- AIR FILTER INSPECT
REPLACE AS NEEDED
- BATTERY TEST & CLEAN
REPLACE AS NEEDED
- BRAKE PADS INSPECT
REPLACE AS NEEDED
- BRAKE FLUID CHANGE
- DRIVE BELT INSPECT
REPLACE AS NEEDED
- FRONT GEARCASE INSPECT
- GENERAL LUBRICATION ALL FITTINGS, PIVOTS, CABLES, ETC.
- TRANSMISSION FLUID INSPECT
- SPARK PLUGS INSPECT
REPLACE AS NEEDED

36 MONTHS

300 HRS | 3,000 MI / 4,800 KM

- ENGINE OIL & OIL FILTER CHANGE
- AIR FILTER INSPECT
REPLACE AS NEEDED
- BATTERY TEST & CLEAN
REPLACE AS NEEDED
- BRAKE PADS INSPECT
REPLACE AS NEEDED
- DRIVE BELT INSPECT
REPLACE AS NEEDED
- FRONT GEARCASE INSPECT
- GENERAL LUBRICATION ALL FITTINGS, PIVOTS, CABLES, ETC.
- TRANSMISSION FLUID INSPECT

FOR A COMPLETE MAINTENANCE SCHEDULE, CHECK YOUR OWNER'S MANUAL



Claims made based off testing and performance of Polaris HD Parts against standard OEM parts made by Polaris and competitor brands under normal use. For more information regarding Polaris HD parts including vehicle compatibility, installation and maintenance, please contact your authorized Polaris ORV dealer.

MAINTENANCE PARTS & FLUIDS

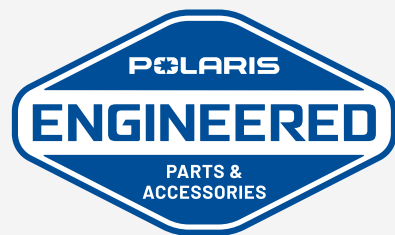

POLARIS ENGINEERED PARTS AND OIL have been validated and tested extensively, specifically for your vehicle. In order to maintain the peak performance of your Polaris vehicle only use official Polaris Engineered parts and oil.



We're taking the passion of our riders, workers, and outdoor enthusiasts to the next level with HD Parts. These Heavy Duty parts are engineered for riders who want greater durability and enhanced performance. HD Parts are designed and tested to handle greater wear and tear under all weather conditions.

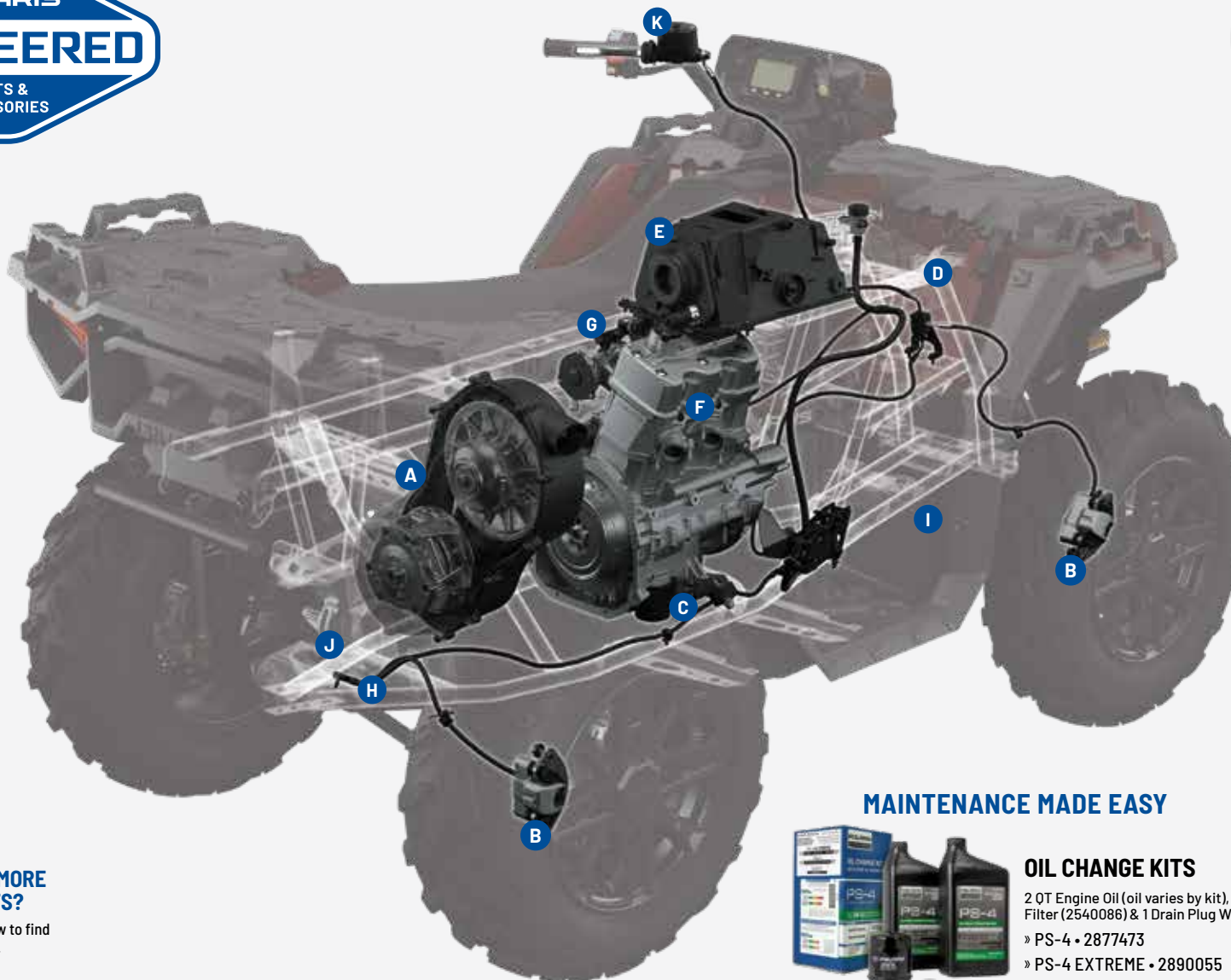

A DRIVE BELT

- » 3211160
850, XP 1000, 850 TOURING, XP 1000 TOURING
- » 3212329
XP 1000 S
- » 3211203
850/ XP 1000 HIGH LIFTER
- » **HD** • 3212331
850, XP 1000, 850 TOURING, XP 1000 TOURING, XP 1000 S

B BRAKE PADS

- » FRONT & REAR • 2205606
850, XP 1000
- » FRONT • 2205606
XP 1000 S
- » REAR • 2208936
XP 1000 S
- » FRONT & REAR • 2207835
850/ XP 1000 HIGH LIFTER

C OIL FILTER

- » 2520799
- » **HD** • 2522485

D BATTERY

- » 4014609

E AIR FILTER

- » 7082101
- » **HD** • 7083114

F SPARK PLUGS

- » 3022438
850, 850 TOURING
- » 3022553
XP 1000, XP 1000 S, XP 1000 TOURING

LOOKING FOR MORE SERVICE PARTS?

See P. 69 to learn how to find parts for your model.

MAINTENANCE MADE EASY



OIL CHANGE KITS

- 2 QT Engine Oil (oil varies by kit), 1 Oil Filter (2540086) & 1 Drain Plug Washer
- » PS-4 • 2877473
 - » PS-4 EXTREME • 2890055

G ENGINE OIL P. 64

- » PS-4 • 1QT • 2876244
- » PS-4 • 1GAL. • 2876245
- » PS-4 EXTREME • 1QT • 2889395
- » PS-4 EXTREME • 1GAL. • 2889396

H ANGLE DRIVE FLUID

- For rear gearcase
- » 1QT • 2889280

I DEMAND DRIVE FLUID

- For front gearcase
- » 1QT • 2877922
 - » 2.5 GAL. • 2877923

J AGL

- For transmission
- » 1QT • 2878068
 - » 1 GAL. • 2878069
 - » EXTREME • 1QT • 2891028

K DOT 4 BRAKE FLUID

- » 12 OZ • 2872189

ALL-SEASON GREASE TUBE

- » 3 OZ • 2871322
- » 14 OZ • 2871423

MAINTENANCE SCHEDULE*

BREAK-IN MAINTENANCE

FIRST 25 HRS | 250 MI / 400 KM

ENGINE OIL & OIL FILTER CHANGE

AIR FILTER INSPECT
REPLACE AS NEEDED

FRONT & REAR GEARCASE INSPECT FLUID

TRANSMISSION CHANGE FLUID

6 MONTHS

50 HRS | 500 MI / 800 KM

DRIVE BELT INSPECT
REPLACE AS NEEDED

AIR FILTER INSPECT
REPLACE AS NEEDED

BATTERY TEST & CLEAN
REPLACE AS NEEDED

GENERAL LUBRICATION
ALL FITTINGS, PIVOTS, CABLES, ETC.

12 MONTHS

100 HRS | 1,000 MI / 1,600 KM

AIR FILTER INSPECT
REPLACE AS NEEDED

ALTERNATOR BELT INSPECT
REPLACE AS NEEDED

BATTERY TEST & CLEAN
REPLACE AS NEEDED

BRAKE PADS INSPECT
REPLACE AS NEEDED

DRIVE BELT INSPECT
REPLACE AS NEEDED

18 MONTHS

150 HRS | 1,500 MI / 2,400 KM

DRIVE BELT INSPECT
REPLACE AS NEEDED

AIR FILTER INSPECT
REPLACE AS NEEDED

BATTERY TEST & CLEAN
REPLACE AS NEEDED

GENERAL LUBRICATION
ALL FITTINGS, PIVOTS, CABLES, ETC.

24 MONTHS

200 HRS | 2,000 MI / 3,200 KM

AIR FILTER INSPECT
REPLACE AS NEEDED

ALTERNATOR BELT INSPECT
REPLACE AS NEEDED

BATTERY TEST & CLEAN
REPLACE AS NEEDED

BRAKE PADS INSPECT
REPLACE AS NEEDED

BRAKE FLUID CHANGE

DRIVE BELT INSPECT
REPLACE AS NEEDED

30 MONTHS

250 HRS | 2,500 MI / 4,000 KM

DRIVE BELT INSPECT
REPLACE AS NEEDED

AIR FILTER INSPECT
REPLACE AS NEEDED

BATTERY TEST & CLEAN
REPLACE AS NEEDED

GENERAL LUBRICATION
ALL FITTINGS, PIVOTS, CABLES, ETC.

DRIVE BELT INSPECT
REPLACE AS NEEDED

36 MONTHS

300 HRS | 3,000 MI / 4,800 KM

AIR FILTER INSPECT
REPLACE AS NEEDED

ALTERNATOR BELT INSPECT
REPLACE AS NEEDED

BATTERY TEST & CLEAN
REPLACE AS NEEDED

BRAKE PADS INSPECT
REPLACE AS NEEDED

DRIVE BELT INSPECT
REPLACE AS NEEDED

ENGINE OIL & OIL FILTER CHANGE

FRONT & REAR GEARCASE CHANGE FLUID

GENERAL LUBRICATION
ALL FITTINGS, PIVOTS, CABLES, ETC.

SPARK PLUGS INSPECT
REPLACE AS NEEDED

TRANSMISSION INSPECT FLUID

FOR A COMPLETE MAINTENANCE SCHEDULE, CHECK YOUR OWNER'S MANUAL



Claims made based off testing and performance of Polaris HD Parts against standard OEM parts made by Polaris and competitor brands under normal use. For more information regarding Polaris HD parts including vehicle compatibility, installation and maintenance, please contact your authorized Polaris ORV dealer.

MAINTENANCE PARTS & FLUIDS

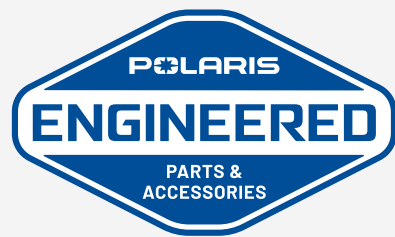

POLARIS ENGINEERED PARTS AND OIL have been validated and tested extensively, specifically for your vehicle. In order to maintain the peak performance of your Polaris vehicle only use official Polaris Engineered parts and oil.



We're taking the passion of our riders, workers, and outdoor enthusiasts to the next level with HD Parts. These Heavy Duty parts are engineered for riders who want greater durability and enhanced performance. HD Parts are designed and tested to handle greater wear and tear under all weather conditions.

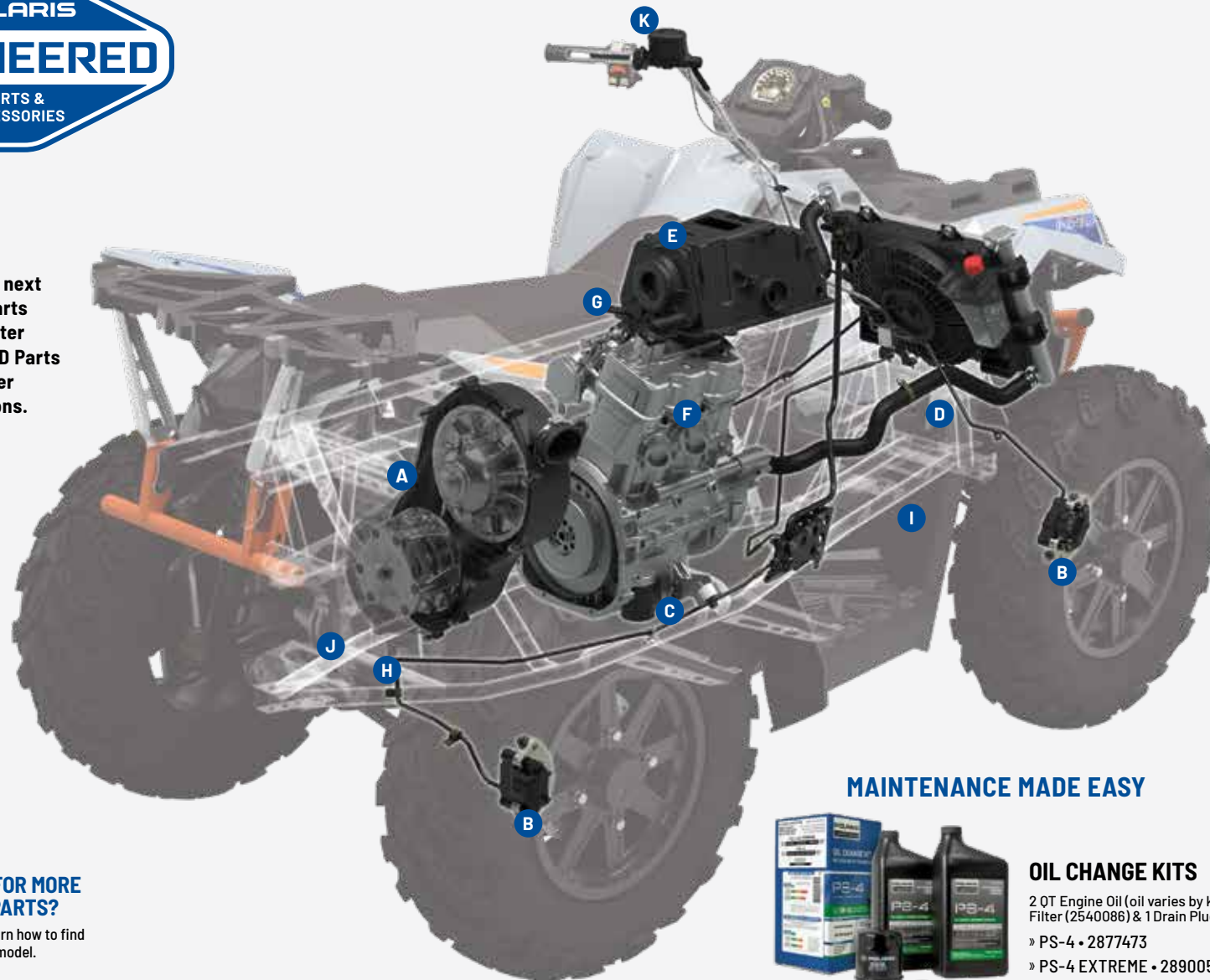

- A DRIVE BELT**
 - » 3211160 SCRAMBLER 850
 - » 3212329 SCRAMBLER XP 1000 S
 - » **HD** • 3212331
- B BRAKE PADS**
 - » FRONT • 2205606
 - » REAR • 2208936
- C OIL FILTER**
 - » 2520799
 - » **HD** • 2522485
- D BATTERY**
 - » 4014609
- E AIR FILTER**
 - » 7082101
 - » **HD** • 7083114
- F SPARK PLUGS**
 - » 3022438 SCRAMBLER 850
 - » 3022553 SCRAMBLER XP 1000 S

LOOKING FOR MORE SERVICE PARTS?
See P. 69 to learn how to find parts for your model.

MAINTENANCE MADE EASY



OIL CHANGE KITS
2 OT Engine Oil (oil varies by kit), 1 Oil Filter (2540086) & 1 Drain Plug Washer
» PS-4 • 2877473
» PS-4 EXTREME • 2890055

- G ENGINE OIL** P. 64
 - » PS-4 • 1QT • 2876244
 - » PS-4 • 1GAL. • 2876245
 - » PS-4 EXTREME • 1QT • 2889395
 - » PS-4 EXTREME • 1GAL. • 2889396
- H ANGLE DRIVE FLUID**
 - For rear gearcase
 - » 1QT • 2889280
- I DEMAND DRIVE FLUID**
 - For front gearcase
 - » 1QT • 2877922
 - » 2.5 GAL. • 2877923
- J AGL**
 - For transmission
 - » 1QT • 2878068
 - » 1GAL. • 2878069
 - » EXTREME • 1QT • 2891028
- K DOT 4 BRAKE FLUID**
 - » 12 OZ • 2872189
- ALL-SEASON GREASE TUBE**
 - » 3 OZ • 2871322
 - » 14 OZ • 2871423

MAINTENANCE SCHEDULE*

Claims made based off testing and performance of Polaris HD Parts against standard OEM parts made by Polaris and competitor brands under normal use. For more information regarding Polaris HD parts including vehicle compatibility, installation and maintenance, please contact your authorized Polaris ORV dealer.

BREAK-IN MAINTENANCE

FIRST 25 HRS | 250 MI / 400 KM

- ENGINE OIL & OIL FILTER**
CHANGE
- AIR FILTER**
INSPECT
REPLACE AS NEEDED
- FRONT & REAR GEARCASE**
CHANGE FLUID
- TRANSMISSION**
CHANGE FLUID

6 MONTHS

50 HRS | 500 MI / 800 KM

- BRAKE PADS**
INSPECT
REPLACE AS NEEDED
- AIR FILTER**
INSPECT
REPLACE AS NEEDED
- DRIVE BELT**
INSPECT
REPLACE AS NEEDED
- BATTERY**
TEST & CLEAN
REPLACE AS NEEDED
- GENERAL LUBRICATION**
ALL FITTINGS, PIVOTS, CABLES, ETC.

12 MONTHS

100 HRS | 1,000 MI / 1,600 KM

- AIR FILTER**
INSPECT
REPLACE AS NEEDED
- BRAKE PADS**
INSPECT
REPLACE AS NEEDED
- ENGINE OIL & OIL FILTER**
CHANGE
- FRONT & REAR GEARCASE**
CHANGE FLUID
- GENERAL LUBRICATION**
ALL FITTINGS, PIVOTS, CABLES, ETC.
- SPARK PLUGS**
INSPECT
REPLACE AS NEEDED
- TRANSMISSION**
CHANGE FLUID

18 MONTHS

150 HRS | 1,500 MI / 2,400 KM

- BRAKE PADS**
INSPECT
REPLACE AS NEEDED
- AIR FILTER**
INSPECT
REPLACE AS NEEDED
- DRIVE BELT**
INSPECT
REPLACE AS NEEDED
- BATTERY**
TEST & CLEAN
REPLACE AS NEEDED
- GENERAL LUBRICATION**
ALL FITTINGS, PIVOTS, CABLES, ETC.

24 MONTHS

200 HRS | 2,000 MI / 3,200 KM

- AIR FILTER**
INSPECT
REPLACE AS NEEDED
- BRAKE PADS / BRAKE FLUID**
INSPECT / CHANGE
REPLACE AS NEEDED / NA
- ENGINE OIL & OIL FILTER**
CHANGE
- FRONT & REAR GEARCASE**
CHANGE FLUID
- GENERAL LUBRICATION**
ALL FITTINGS, PIVOTS, CABLES, ETC.
- SPARK PLUGS**
INSPECT
REPLACE AS NEEDED
- TRANSMISSION**
CHANGE FLUID

30 MONTHS

250 HRS | 2,500 MI / 4,000 KM

- BRAKE PADS**
INSPECT
REPLACE AS NEEDED
- AIR FILTER**
INSPECT
REPLACE AS NEEDED
- DRIVE BELT**
INSPECT
REPLACE AS NEEDED
- BATTERY**
TEST & CLEAN
REPLACE AS NEEDED
- GENERAL LUBRICATION**
ALL FITTINGS, PIVOTS, CABLES, ETC.

36 MONTHS

300 HRS | 3,000 MI / 4,800 KM

- AIR FILTER**
INSPECT
REPLACE AS NEEDED
- BRAKE PADS**
INSPECT
REPLACE AS NEEDED
- ENGINE OIL & OIL FILTER**
CHANGE
- FRONT & REAR GEARCASE**
CHANGE FLUID
- GENERAL LUBRICATION**
ALL FITTINGS, PIVOTS, CABLES, ETC.
- SPARK PLUGS**
INSPECT
REPLACE AS NEEDED
- TRANSMISSION**
CHANGE FLUID

FOR A COMPLETE MAINTENANCE SCHEDULE, CHECK YOUR OWNER'S MANUAL



*This is a sample maintenance schedule. Please reference and use your owners manual for full maintenance and vehicle care.

MISCELLANEOUS

ACCESSORIES



CHAINSAW MOUNT

- Heavy-duty, black powder-coated metal bracket is designed to transport your chain saw securely
- With Lock & Ride technology, it can be secured to the outside of the rack in seconds, without tools, so your chainsaw is within reach at all times
- Accommodates any brand electric chainsaw (sold separately)
- Rubber pads provide cushion and tight fit
- 15 lbs weight capacity

» 2890580

SPORTSMAN 450 H.O. '21-25, SPORTSMAN 570 '21-25, SPORTSMAN TOURING 570 '25



QUICKTAP BATTERY POSTS

- Easy-to-access terminal posts give you quick access to the battery power
- Ideal for charging your battery, powering a temporary accessory, or when you need to offer an unexpected jump-start
- Connection posts feature covers to protect terminals when not in use

» 2882110



ATV LICENSE PLATE

- Includes numbers and letters

» 2873270



RECOVERY STRAP

- 2" x 30' (18,000 lb.)
- Comes with carry bag

» 2884033

TRAILERING AND ADDITIONAL STRAPS P. 60

SPORTSMAN YOUTH MAINTENANCE PARTS & FLUIDS



POLARIS ENGINEERED PARTS AND OIL have been validated and tested extensively, specifically for your vehicle. In order to maintain the peak performance of your Polaris vehicle only use official Polaris Engineered parts and oil.



DRIVE BELT

- » 3023904
OUTLAW 70 EFI
- » 0453455
OUTLAW 110, SPORTSMAN 110
- » 0452496
PHOENIX 200



BRAKE PADS

- » FRONT/REAR • 2208176
OUTLAW 70 EFI
- » FRONT • 0455315
OUTLAW 110, SPORTSMAN 110
- » REAR • 0455441
OUTLAW 110, SPORTSMAN 110
- » FRONT • 0454664
PHOENIX 200



OIL FILTER

- » 3023869
OUTLAW 70 EFI
- » 0452462
PHOENIX 200



BATTERY

- » 4010678
OUTLAW 70 EFI
- » 4011181
OUTLAW 110, SPORTSMAN 110
- » 4011434
PHOENIX 200



AIR FILTER

- » 7082513
OUTLAW 70 EFI
- » 0454620
OUTLAW 110, SPORTSMAN 110
- » 1253355
PHOENIX 200



SPARK PLUGS

- » 3023835
OUTLAW 70 EFI
- » 0453034
OUTLAW 110
- » 3023835
PHOENIX 200



ENGINE OIL

SEE P. 64 FOR DETAILS



ANGLE DRIVE FLUID

- » 1QT • 2889280
PHOENIX 200



AGL

- » 1QT • 2878068
- » 1 GAL. • 2878069
- » EXTREME • 1QT • 2891028



DOT 4 BRAKE FLUID

- » 12 OZ • 2872189



ALL-SEASON GREASE TUBE

- » 3 OZ • 2871322
- » 14 OZ • 2871423

YOUTH ATV OUTLAW 70 EFI

The perfect first all-terrain vehicle for kids starting at 6 years and older.



FRONT BRUSHGUARD

- Provides enhanced protection from brush and other debris on the trail

» 2884567

OUTLAW 70 EFI '21-25



WINDSHIELD - POLY

- Added wind and hand protection with a durable poly design

» 2885005

OUTLAW 70 EFI '21-25



REAR BRUSHGUARD

- Protect the rear of your youth ATV on the trails

» 2884778

OUTLAW 70 EFI '21-25



REAR STORAGE BAG

- Convenient storage that easily connects to the rear rack

» 2884555

OUTLAW 70 EFI '21-25

MAINTENANCE SCHEDULE*

BREAK-IN MAINTENANCE

FIRST 10 HRS | 100 MI / 160 KM

- AIR FILTER INSPECT & CLEAN
REPLACE AS NEEDED
- ENGINE OIL & FILTER CHANGE
- TRANSMISSION OIL CHANGE
- DRIVE CHAIN ADJUST & LUBRICATE

1 MONTH

20 HRS | 200 MI / 320 KM

- BATTERY CLEAN & TEST
- ENGINE OIL & FILTER CHANGE

6 MONTHS

50 HRS | 500 MI / 800 KM

- GENERAL LUBRICATION ALL FITTINGS, PIVOTS, CABLES, ETC.
- BRAKE PADS INSPECT
REPLACE AS NEEDED
- DRIVE BELT INSPECT
REPLACE AS NEEDED

8 MONTHS

60 HRS | 700 MI / 1000 KM

- AIR FILTER INSPECT & CLEAN
REPLACE AS NEEDED
- SPARK PLUG INSPECT & CLEAN
REPLACE AS NEEDED

12 MONTHS

100 HRS | 1000 MI / 1600 KM

- TRANSMISSION OIL CHANGE
- DRIVE BELT INSPECT
REPLACE AS NEEDED

FOR A COMPLETE MAINTENANCE SCHEDULE, CHECK YOUR OWNER'S MANUAL



*This is a sample maintenance schedule. Please reference and use your owners manual for full maintenance and vehicle care.