

ALUMINUM ROOF KIT



P/N 2879443, 2881582

APPLICATION

Verify accessory fitment at Polaris.com.

BEFORE YOU BEGIN

Read these instructions and check to be sure all parts and tools are accounted for. Please retain these installation instructions for future reference and parts ordering information.

KIT CONTENTS

This Kit includes:

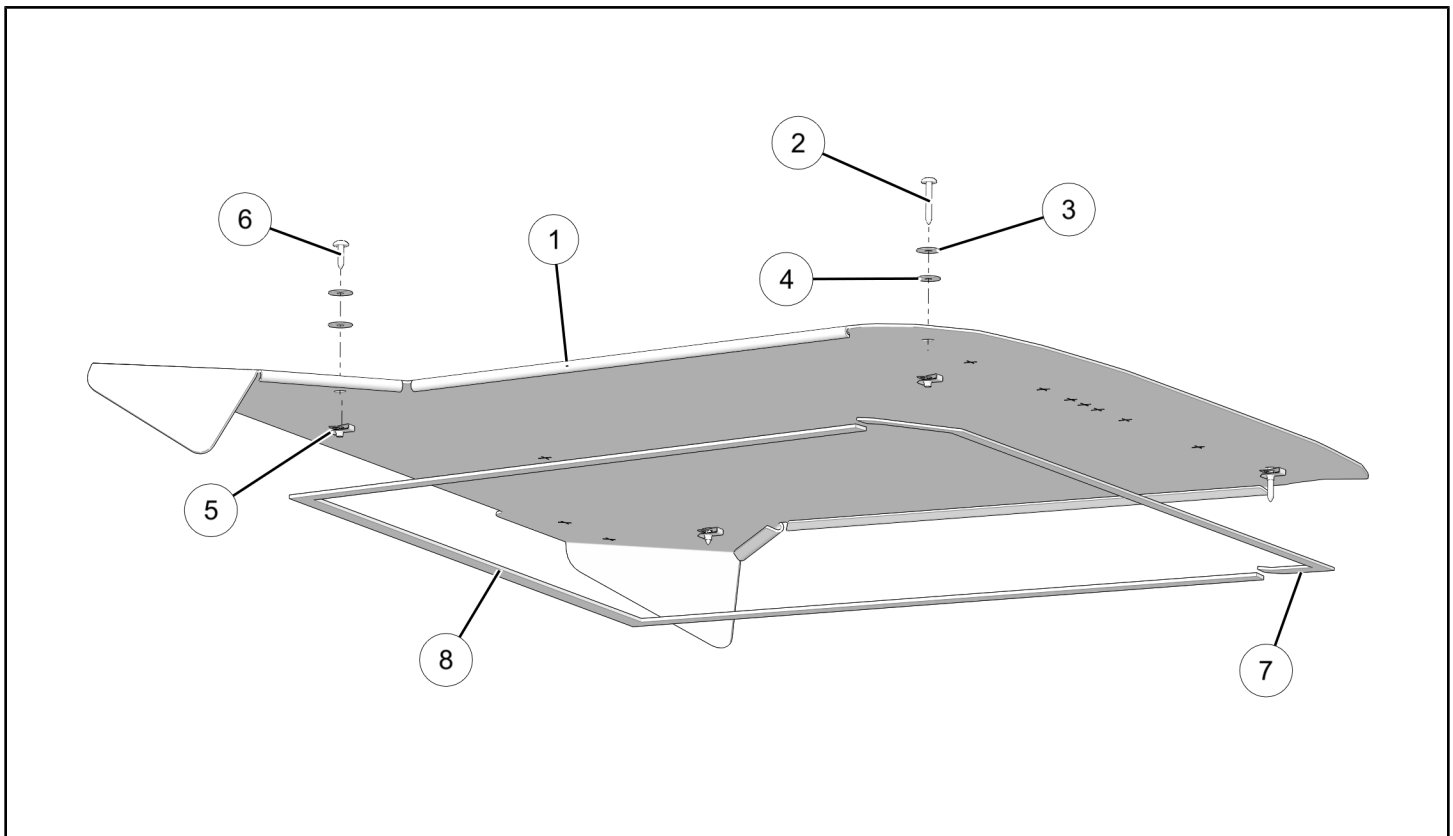

REF	QTY	PART DESCRIPTION	PART NUMBER
1	1	Roof, Aluminum	-
2*	2	Screw, Torx® - M6 X 1.0 X 45	7519722
3*	4	Washer, Steel - 0.281 X 1.00 X 0.051	7556329
4*	4	Washer, Rubber - 0.281 X 1.00 X 0.051	-
5*	4	Clip Nut	7081305
6*	2	Screw, Torx® - M6 X 1.0 X 25	7519650
7	1	Seal, Front, 20 X 3	-

REF	QTY	PART DESCRIPTION	PART NUMBER
8	1	Seal, Rear, 20 X 10	-
		Instructions	9924452

Items marked (*) are included in Hardware Kit PN 2205204.

TOOLS REQUIRED

- Safety Glasses
- Socket Set, Torx® Bit
- Torque Wrench
- Utility Knife/Cutting Tool

IMPORTANT

Your Aluminum Roof Kit is exclusively designed for your vehicle. Please read the installation instructions thoroughly before beginning. Installation is easier if the vehicle is clean and free of debris. For your safety, and to ensure a satisfactory installation, perform all installation steps correctly in the sequence shown.

ASSEMBLY TIME

Approximately 15 minutes

INSTALLATION INSTRUCTIONS

1. Shift vehicle transmission into “PARK”. Turn key to “OFF” position and remove from vehicle.
2. Remove two screws (A) from upper rear side of visor as shown. Screws will not be reused.
3. Install two clip nuts (5) to outer flanges of rear frame as shown. Inner flanges will not be used.

NOTE

Do not remove two screws from lower front side of visor. Roof ① will be installed on top of visor.

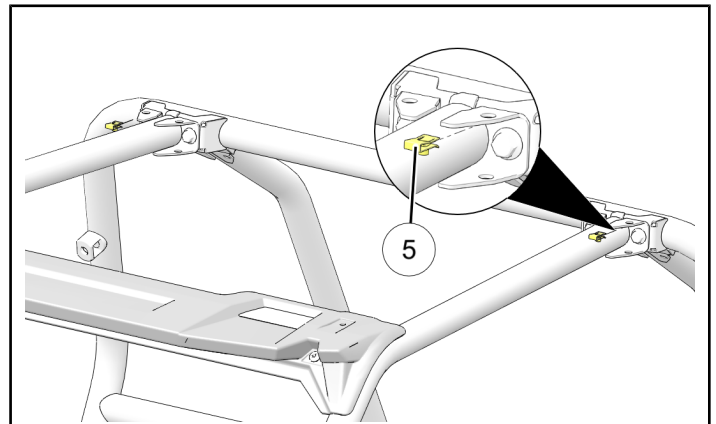
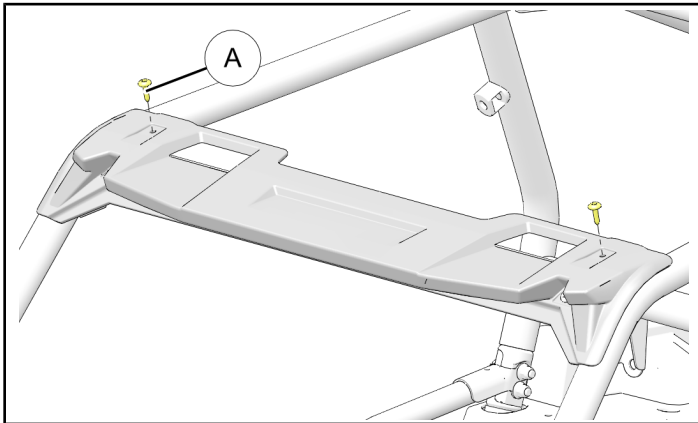

4. OPTIONAL: Two existing clip nuts (B) on outer flanges of front frame may remain if in good condition. Otherwise, replace with new clip nuts (5).

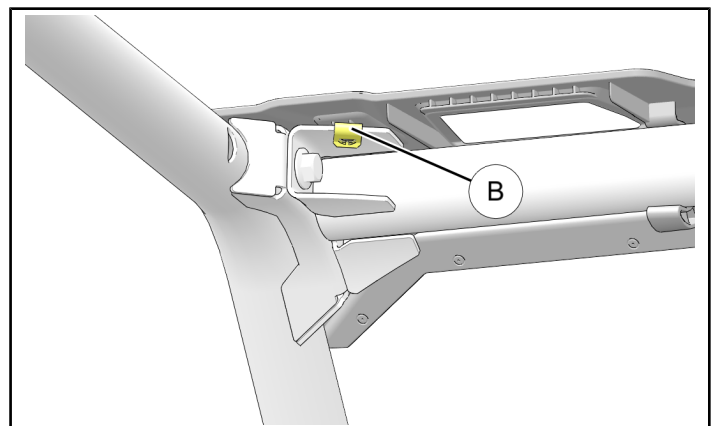

5. Clean lower surface of roof ① as required, then apply thin front seal ⑦ and thick rear seal ⑧ as shown. Seals should be applied on INSIDE edge of alignment marks. Trim seals as required.

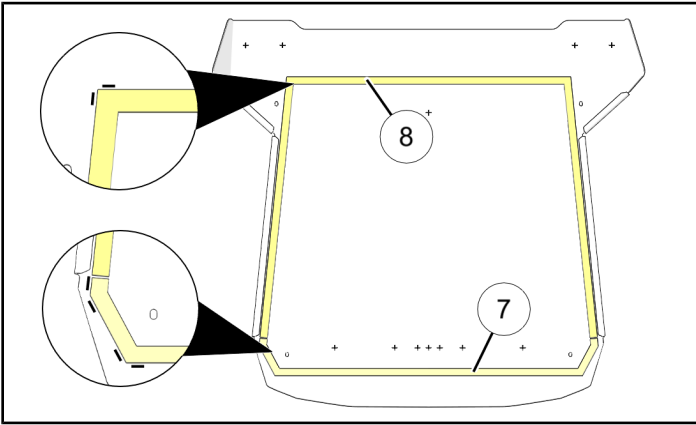

6. Loosely install front of roof ① using two each 45 mm screws ②, steel washers ③, and rubber washers ④ as shown. Ensure steel washer is beneath screw head, and rubber washer is against roof.

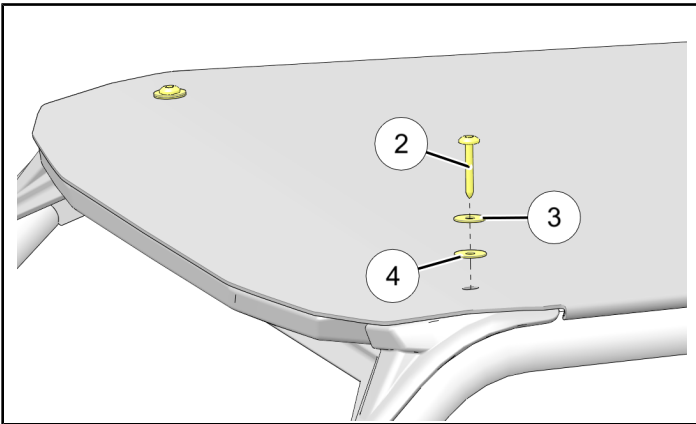

7. Loosely install rear of roof ① using two each 25 mm screws ⑥, steel washers ③, and rubber washers ④ as shown. Ensure steel washer is beneath screw head, and rubber washer is against roof.

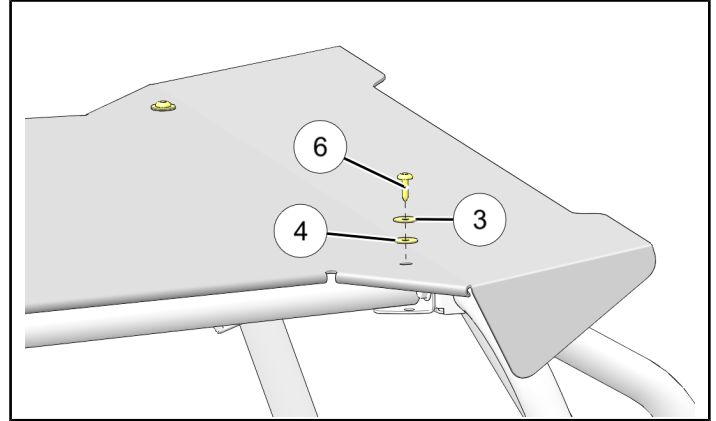

8. Torque all screws to specification.

NOTE

8 ft. lbs. (11 Nm)