

FENDER FLARE KIT



P/N 2882455

APPLICATION

Verify accessory fitment at Polaris.com.

BEFORE YOU BEGIN

Read these instructions and check to be sure all parts and tools are accounted for. Please retain these installation instructions for future reference and parts ordering information.

KIT CONTENTS

This Kit includes:

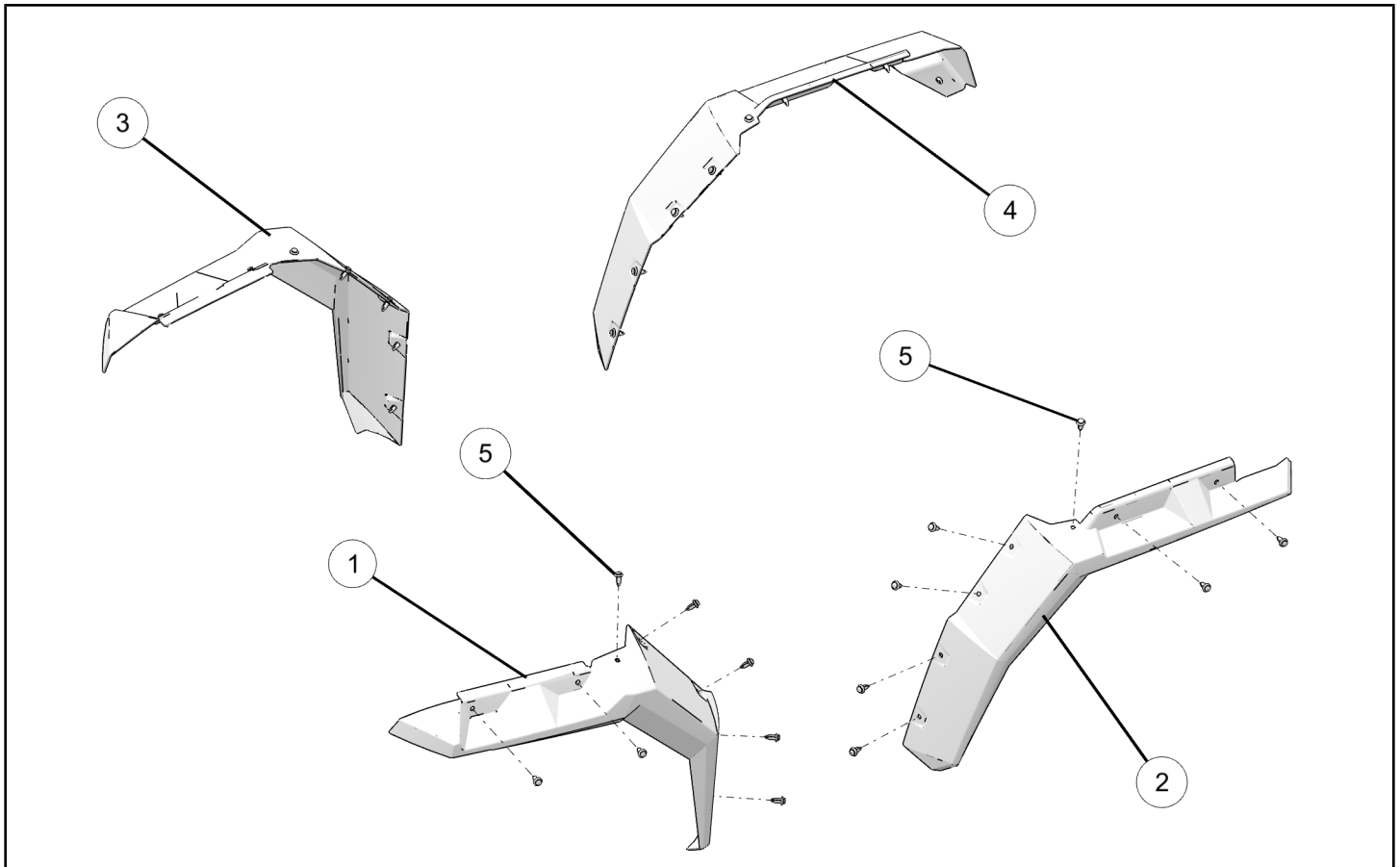

REF	QTY	PART DESCRIPTION	PART NUMBER
1	1	Front Fender Flare, LH	5453839
2	1	Rear Fender Flare, LH	5453841
3	1	Front Fender Flare, RH	5453840
4	1	Rear Fender Flare, RH	5453842
5	30	Tuflok Rivet - 0.315 - 0.325 X 0.787	7661855
	1	Instructions	9927752

TOOLS REQUIRED

- Safety Glasses
- Drill and 5/16" Drill Bit
- Torx® Wrench

- Pliers
- 10mm Socket and Ratchet

IMPORTANT

Your FENDER FLARE KIT is exclusively designed for your vehicle. Please read the installation instructions thoroughly before beginning. Installation is easier if the vehicle is clean and free of debris. For your safety, and to ensure a satisfactory installation, perform all installation steps correctly in the sequence shown.

ASSEMBLY TIME

Approximately 20 minutes

INSTALLATION INSTRUCTIONS

1. Place vehicle in "PARK". Turn key to "OFF" position and remove from vehicle.

NOTE

If your vehicle has factory installed fender flares, follow Steps 2 and 3 for removing factory fender flares, skip Step 4. If your vehicle doesn't have factory installed fender flares, proceed to Step 4.

2. Remove factory installed front LH fender flare (B) by removing two screws (A) and four rivets (C) as shown. Discard all fasteners. Repeat same on other side of the vehicle.

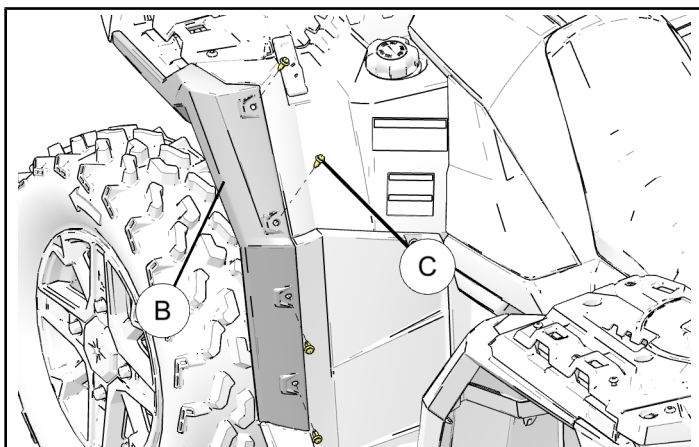
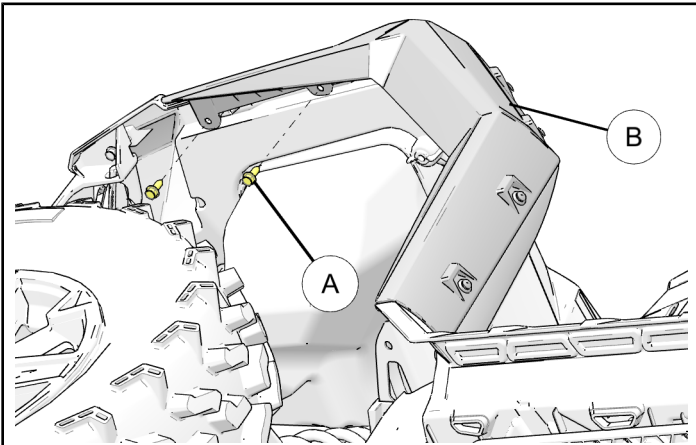

3. Remove factory installed rear LH fender flare (E) by removing two screws (D) and four rivets (F) as shown. Discard all fasteners. Repeat same on other side of the vehicle.

NOTE

Proceed to Step 5 at this stage.

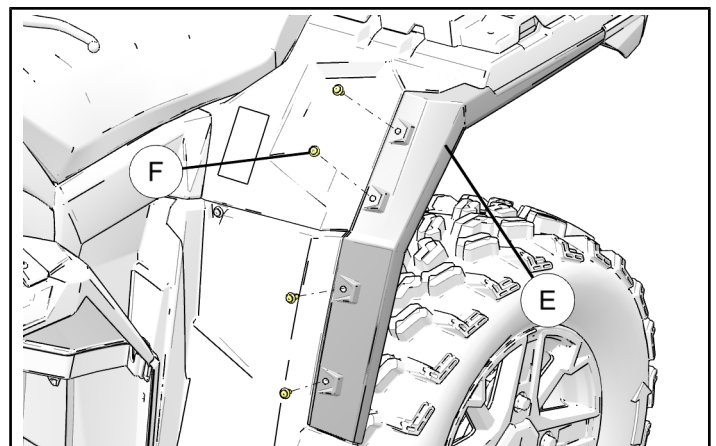
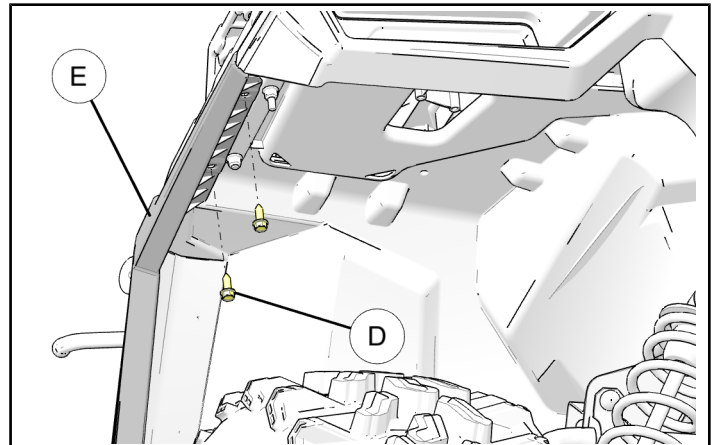

4. Locate four moulded dimples on underside of front and rear factory body panels (G) and (H) as shown. Drill holes in these locations using dimples as guides for installing new kit supplied fender flare rivets.

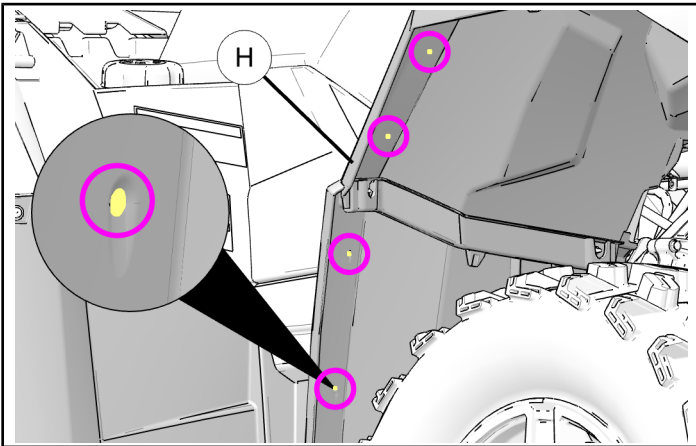
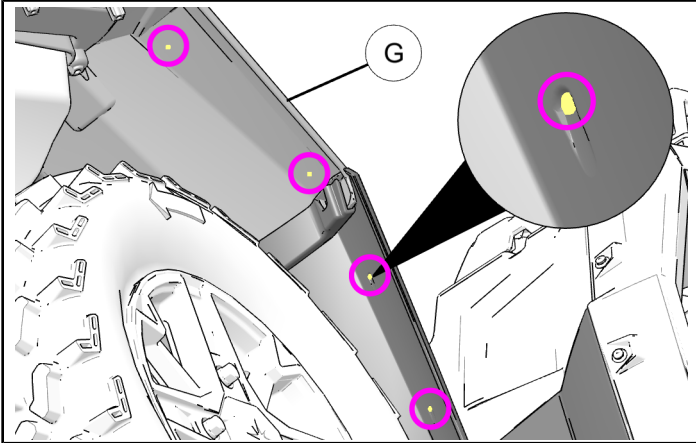

5. Align front LH fender flare ① with vehicle body panel (G) as shown. Using existing holes on fender flare as templates, mark three holes on body panel in the locations as shown.

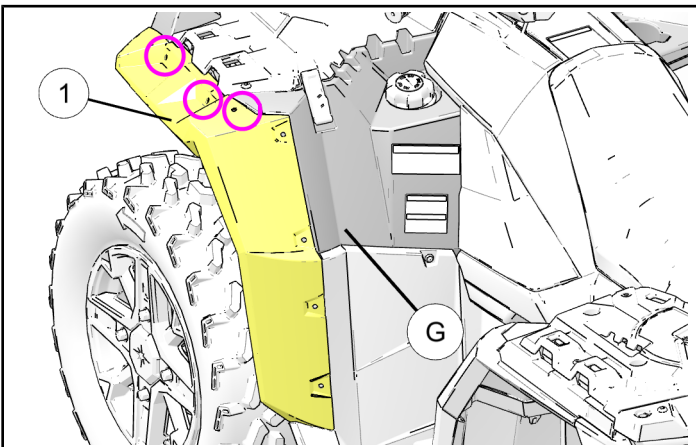

6. Drill three holes in the marked location on vehicle body panel (G) using 5/16" drill bit.

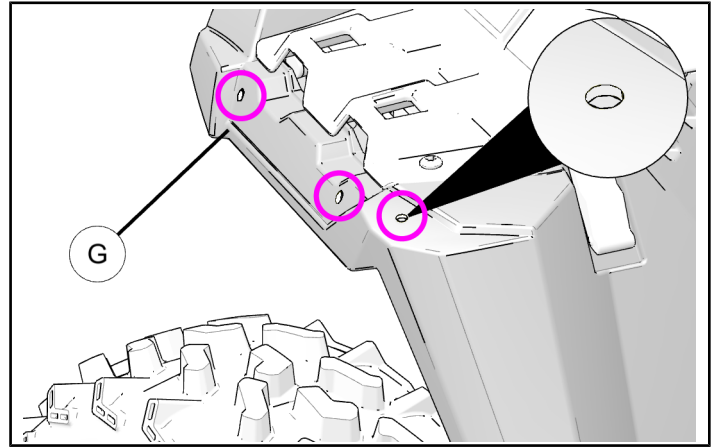

7. Align and install front LH fender flare ① on vehicle body panel using seven tuflok rivets ⑤ as shown. Repeat same on other side of vehicle.

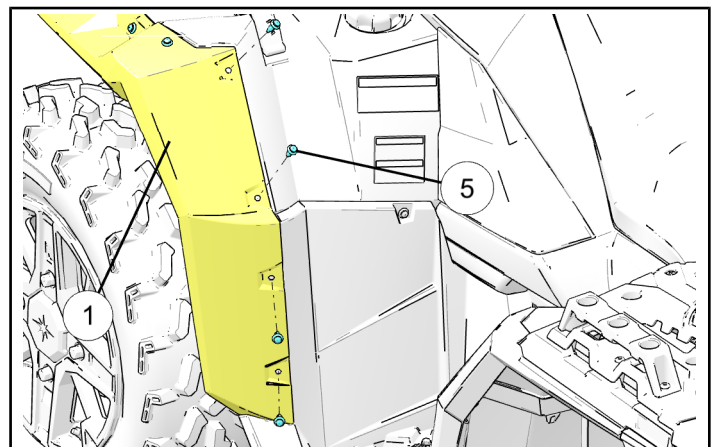

8. Align rear LH fender flare ② with vehicle body panel (H) as shown. Using existing holes on fender flare as templates, mark three holes on body panel in the locations as shown.

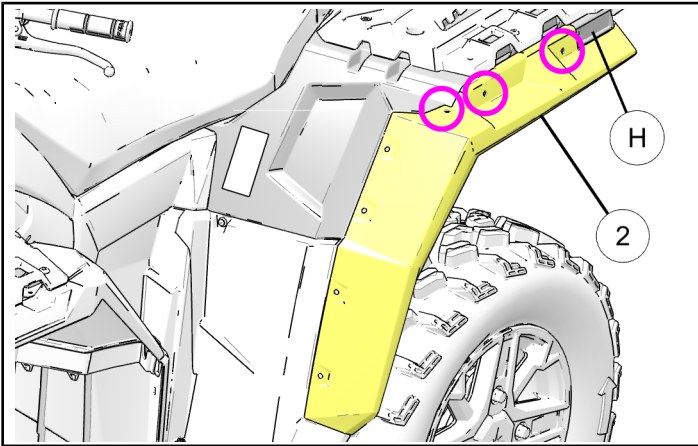

9. Drill three holes in the marked location on vehicle body panel (H) using 5/16" drill bit.

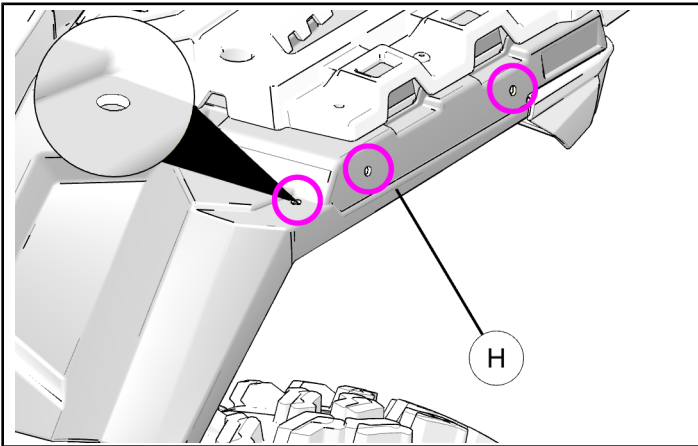

10. Align and install rear LH fender flare ② on vehicle body panel using seven tuflok rivets ⑤ as shown. Repeat same on other side of vehicle.

