

OIL CHANGE ATV, SINGLE/TWIN CYLINDER, KIT



POLARIS
The Way Out.®

KIT P/N 2876380

Application

Polaris Sportsman, Ranger, Magnum ATV's

Before you begin, read these instructions and check to be sure all parts and tools are accounted for. Please retain these installation instructions for future reference and parts ordering information.

This kit includes:

Qty.	Part Description	Part No.
2	Quart Polaris Premium ATV/Utility Synthetic	2871281
1	Oil Filter	2540086
1	Instructions	9921260

You will need to supply:

Shop Rags
Drain Pan
Loctite™ Thread Sealant 505
Oil Filter Wrench (PV-43527)

IMPORTANT: Always change the oil at the intervals outlined in the Periodic Maintenance Table published in the owner's manual.

Oil/Filter Change Instructions

Recommended Engine Oil: Polaris Premium ATV/Utility Synthetic (PN 2871281)

Use Oil Filter Wrench (PV-43527)

Oil Filter Torque: Turn by hand until filter gasket contacts sealing surface, then turn and additional 1/2 turn.

WARNING

Personal injury can occur when handling used oil. Do not allow hot oil to come into contact with your skin. Hot oil can cause burns or skin damage.

NOTICE: Care must be taken to ensure that the fluids are contained. Be prepared to collect the fluid with suitable containers before opening any compartment or disassembly of any component containing fluids.

1. Place vehicle on a level surface.
2. Clean area around drain plug **(A)** at bottom of oil tank. (Illus. 3)
3. Run engine two to three minutes until the engine is warm.
4. After two or three minutes stop the engine.

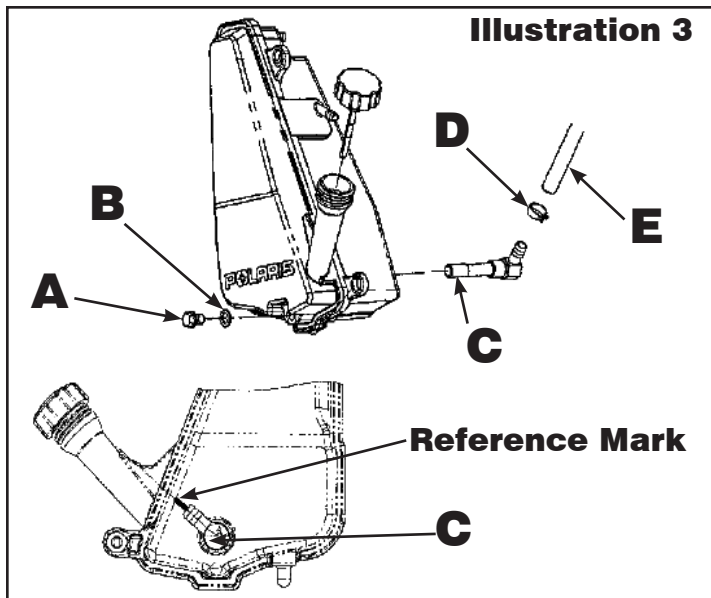

5. Place a drain pan beneath oil tank and remove the drain plug (A). (Illus. 3)
- CAUTION:** Oil may be hot. Do not allow hot oil to come into contact with skin as serious burns may result.
6. Allow oil to drain completely.
- NOTE:** The sealing surfaces on the drain plug and the oil tank should be clean and free of burrs, nicks or scratches.
7. Reinstall the drain plug (A) and torque it to specification. (Illus 3) Oil tank drain torque, 14ft. lbs. (19 Nm).
 8. Loosen clamp (D). (Illus 3)

9. Remove oil hose (E) from screen fitting (C) on bottom of oil tank. (Illus 3)
10. Remove screen fitting (C) and clean the screen. (Illus 3)
11. Apply Loctite™ thread sealant 505 or an equivalent pipe thread sealant or PTFE sealant tape to clean, oil free threads of fitting (C). (Illus 3)
12. Install screen fitting (C) and rotate a minimum of 2 1/2 turns (clockwise) into the tank threads. (Illus 3) Then rotate the screen fitting clockwise until the nipple of the screen fitting aligns with the reference marking on the tank.



CAUTION

Maximum torque for the screen fitting is 25 ft-lb (34 Nm), do not over tighten.

13. Install oil hose (E) on fitting (C) and re-install clamp (D). (Illus 3)
14. Place shop towels beneath oil filter. Use Oil Filter Wrench (PV-43527), turn filter counterclockwise to remove. (Illus 4)
15. Using a clean dry cloth, clean filter sealing surface on the crankcase.
16. Lubricate the o-ring on new filter with a thin film of engine oil. Check to make sure the O-ring is in good condition.

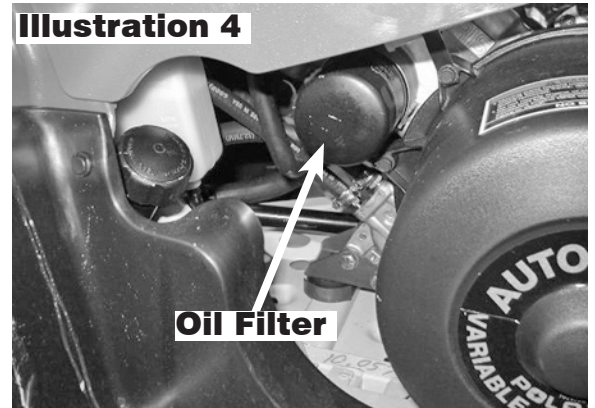

17. Install the new filter and turn it by hand until the filter gasket contacts the sealing surface, then turn an additional 1/2 of a turn. (Illus 4)
18. See Owner's Manual for engine sump drain procedure of desired. One extra quart of oil will be needed to proceed.

NOTE: The sealing surfaces on the drain plug and crankcase should be clean and free of burrs, nicks or scratches.

19. Reinstall drain plug and torque to specification.
20. Remove dipstick and fill tank with 2 quarts (1.9 L) of Polaris Premium Synthetic Oil.
21. Place gear selector in Park and set parking brake.

325, 330, 400, 500 ATV's

Engine Oil Level

The oil tank is located on the left side of the vehicle. To check the oil level:

1. Place machine on a level surface.
2. Clean the area around the dip stick.
3. Start and run engine for 20-30 seconds. This will return oil to its true level in the oil tank.
4. Stop engine, remove dipstick **(A)** and wipe dry with a clean cloth. (Ilus. 1)

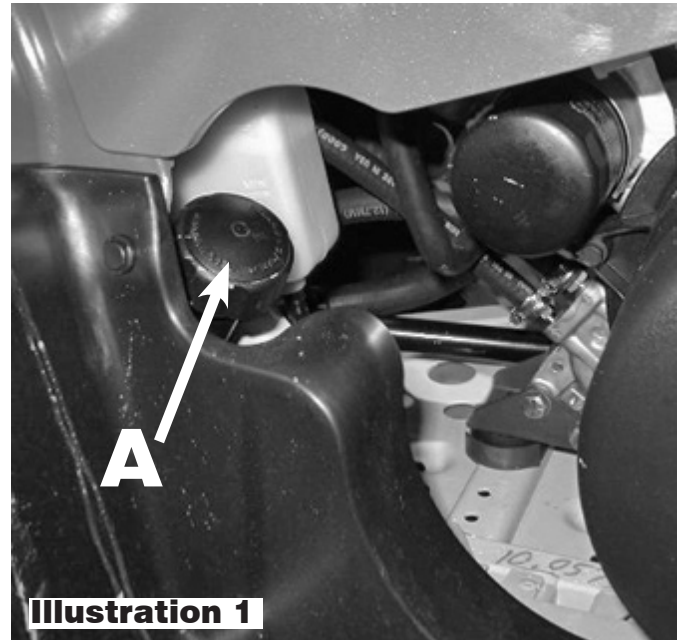

Illustration 1

5. Reinstall dipstick, screw the dipstick into place.

NOTE: The dipstick must be screwed completely in to ensure accurate measurement.

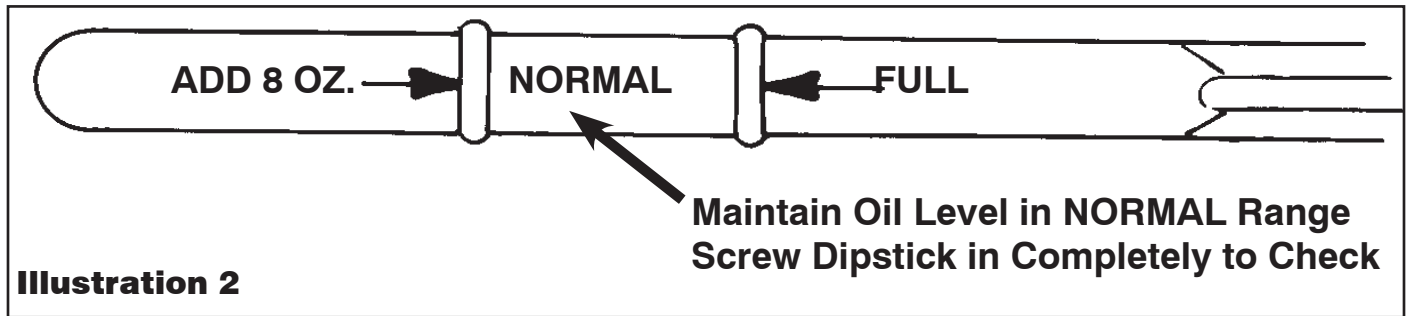

Illustration 2

6. Remove dipstick and check to see that the oil level is in the normal range. The oil should be between the top line and the bottom line on the dipstick. Add oil as indicated by the level on the dipstick. **DO NOT OVERFILL.**

NOTE: Rising oil level between checks in cool weather driving, can indicate moisture collecting in the oil reservoir. If the oil level is over the full mark, change the oil.

600/700/800 ATV's

Oil/Filter Change Instructions

Recommended Engine Oil: Polaris Premium ATV/Utility Synthetic (PN 2871281)

Use Oil Filter Wrench (PV-43527)

Oil Filter Torque: Turn by hand until filter gasket contacts sealing surface, then turn and additional 1/2 turn.

WARNING

Personal injury can occur when handling used oil. Do not allow hot oil to come into contact with your skin. Hot oil can cause burns or skin damage.

1. Place vehicle on a level surface.
2. Run engine two to three minutes until warm. Stop engine.
3. Clean area around drain plug at bottom of engine.
4. Place a drain pan beneath crankcase and remove drain plug.
5. Allow oil to drain completely.
6. Replace the sealing washer on drain plug, if necessary.

NOTE: The sealing surfaces on drain plug and oil tank should be clean and free of burrs, nicks or scratches.

7. Reinstall drain plug and torque to specification.
Drain Plug Torque:
15 ± 2 ft.lbs. (21.7 ± 2.7 Nm)
8. Place shop towels beneath oil filter. Using Oil Filter Wrench PV-43527, turn filter counter-clockwise to remove.

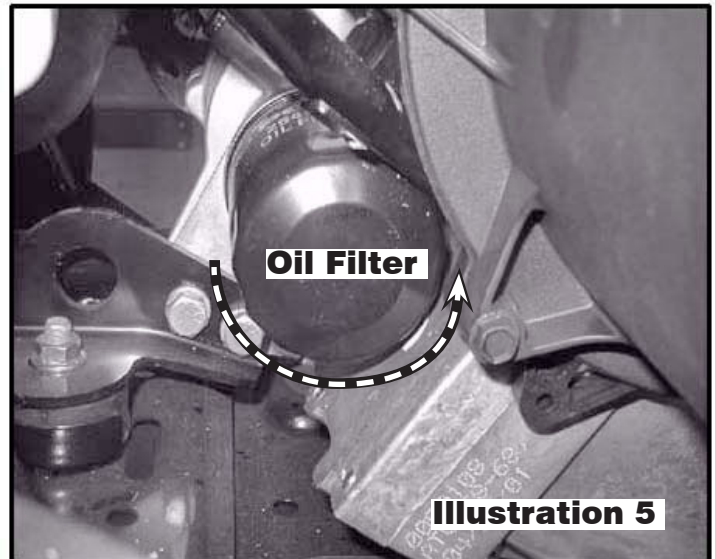

9. Using a clean dry cloth, clean filter sealing surface on crankcase.
10. Lubricate O-ring on new filter with a film of fresh engine oil. Check to make sure the O-ring is in good condition.
11. Install new filter and turn by hand until filter gasket contacts the sealing surface, then turn an additional 1/2 turn.
12. Remove dipstick and fill sump with 2 quarts (1.9 l) of Polaris Premium Synthetic Oil.
13. Place gear selector in park and set the parking brake.
14. Start the engine and let it idle for one to two minutes. Stop the engine and inspect for leaks.
15. Re-check the oil level on the dipstick and add oil as necessary to bring the level to the upper mark on the dipstick.
16. Dispose of used filter and oil properly.