

ELECTRIC START KIT KIT PN 2871597



Application

1997 Indy 3 Cylinder Snowmobiles with Single Pipes

Before you begin, read these instructions and check to be sure all parts and tools are accounted for.

Please retain these installation instructions for future reference and parts ordering information.

The contents of this kit include:

<u>Qty.</u>	<u>Part Description</u>	<u>Part No.</u>
1	Battery Box (Black)	1011932-067
1	Battery	4140006
1	Tube, Battery Vent	5432077
1	Starter Harness	2460392
1	Cable (Battery/Solenoid)	2460393
4	Nylon locking nuts #10-24	7541925
4	Washer, #10	7558203
1	16" Starter Cable (Red)	4010088
1	11" Starter Cable (Black)	4010114
2	Small Insulator Cable (Red)	5410346
2	Screw, #10-16 x 5/8"	7512009
1	Ignition Switch Nut	7543101
1	Bushing-Open/Close	7080399
1	Starter Assembly	2410062
5	Cable Tie	7080138
1	Ignition Switch Assembly	2410010
6	Rivet 3/16" (.063-.25)	7621472
2	Bushing 1.00 x 1.25 x .060	7556509
1	Drive Clutch Assembly	1321734
1	Circuit Breaker	2434008
1	Rectifier	4060064
1	Bolt, #10-24 x 3/4" HX	7511930
1	Battery Strap	5410424
2	D Hook	5224468
6	Battery Pad	5810508
1	Washer, Clutch Retainer	5010278
3	Washer, 5/16"	7555734
1	Single Circuit Housing	4020140
1	Bolt, 10-24 x 5/8"	7511989
1	Kit - Battery Bolt	2200361
1	Instructions	9913971

You will need to supply:

5/16" Socket (8 mm)	Clutch Puller (PN 2870506)	Phillips Screwdriver
12 mm Socket	Strap Wrench (PN 2870336)	Drill
10 mm Wrench	1/8" Allen Wrench (3 mm)	3/16" Drill Bit
12 mm Wrench	3/8" Combination Wrench (10 mm)	3/8" Socket
1/2" Wrench (13 mm)	Torque Wrench	9/32" Drill Bit
Electrolyte		

IMPORTANT: Perform all items correctly and completely.

INSTALLATION INSTRUCTIONS

1. Remove vent plug from vent fitting of battery (PN 4140006).
2. Fill battery with electrolyte to upper level marks on case. See Illustration. **WARNING:** Battery electrolyte contains sulfuric acid and is poisonous! Serious burns can result from contact with the skin, eyes or clothing.
3. Set battery aside and allow it to cool and stabilize for 1/2 hour.
4. Add electrolyte to bring level back to upper level mark on case. **NOTE:** This is the last time that electrolyte should be added. If the level becomes low after this point, add only distilled water.
5. Charge battery at 1/3 of its amp/hr rating for up to two hours. **NOTE:** This charge rate is to be used only on new batteries during the first-time charge. After this charge, they should be charged at the normal 1/10 of amp/hr charge rate.
6. Check specific gravity of each cell with a hydrometer to assure each has a reading of 1.270 or higher.
7. Lift hood, release springs holding muffler, and remove muffler.
8. Open clutch guard and remove drive belt and drive clutch.
9. Remove spring and weights from drive clutch. See Snowmobile Service Manual Chapter 7 for instructions.
10. Install spring and weights removed in previous step into clutch assembly (PN 1321734) and set aside.
11. Locate starter/solenoid cable (PN 410088) from kit. With starter set stud facing down, attach the end with the red insulator cap to the stud on the starter. Secure with nylok nut (PN 7542103). Pull insulator cap over nut.
12. Attach front starter bracket (PN 5241316) to engine crank case using allen head bolts (PN 7516730). Finger-tighten, do not torque at this time.
13. Attach rear starter bracket (PN 5241786) to starter using nuts (PN 7542153) Make sure cable is pointing down and away from engine. Tighten securely.
14. Slide pinion gear side of starter into starter bracket on engine.
15. Attach large end of battery cable (PN 4010114) to top hole of starter bracket, into starter using bolt (PN 7515548) and washer (PN 7553001). Install bolt and washer into lower bracket hole to secure starter to bracket. Tighten securely.
16. Tighten front starter bracket securely.

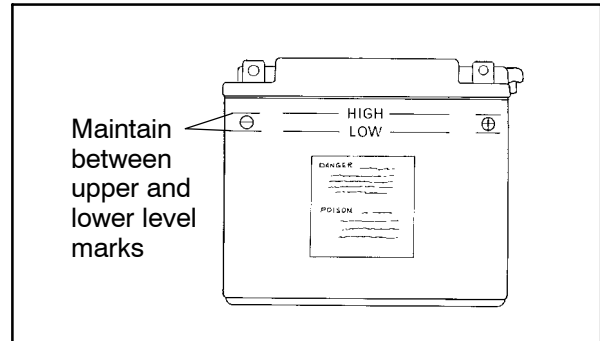

Step 2.

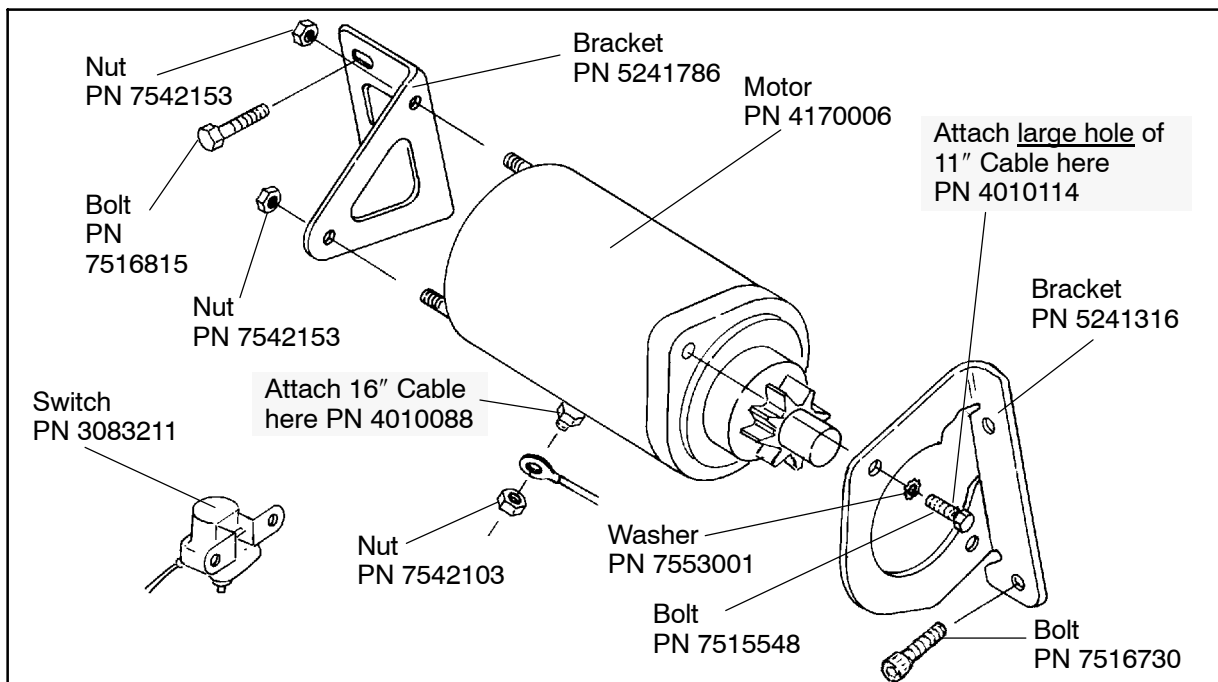

17. Loosely install drive clutch assembly to engine.
18. Check for a minimum of 1/4" (.64 cm) clearance between clutch ring gear and bulkhead. See Illustration. Also check to see if ring gear clears at forward end. If additional clearance is needed, bulkhead may be tapped inward with a soft face hammer. **NOTE:** A minimum of 1/4" (.64 cm) clearance is required. When high torque loads are placed on the engine, the rear of the clutch will move closer to the bulkhead.
19. Position starter motor so there is no less than .100" (.25 cm) clearance between clutch ring gear and starter motor pinion gear. See Illustration.
20. Tighten rear starter bracket (PN 5241786) to crankcase. Torque to 55 in. lbs.
21. Torque drive clutch to 45 ft. lbs.
22. Check driven clutch offset and adjust if needed. **NOTE:** Clutch offset with ring gear installed is 1" (2.54 cm). Add washers (PN 7555734) to clutch bolt as required. See Snowmobile Service Manual for additional instructions.
23. Reinstall drive belt and close clutch guard.
24. Mount the rectifier (PN 4060064) in the inside of the three holes on the footrest. See Illustration. Secure using one 10-24 x 3/4" bolt (PN 7511930) and 10-24 lock nut (PN 7541925)
25. From the back side of the dash, unplug the wires that are attached to the ignition switch.
26. Remove nut on front side of ignition switch and pull switch out through back of dash.
27. Making sure notches in dash and grooves in ignition switch line up, insert the new ignition switch (PN 2410010) from the kit through the back side of panel.
28. Install ignition switch nut (PN 7543101) onto key side of ignition switch. **NOTE:** The amount that the ignition switch sticks out of the dash can be changed by adjusting the nut and lockwasher on the back side of the dash.
29. Remove the insulating cover from the existing ignition switch wires. Place these wires in the new starter harness housing as shown in illustration.
30. Connect to back of key switch.
31. Attach the two yellow wires to the AC terminals on the rectifier. See Illustration.
32. Attach the red wire to the rectifier positive terminal. See Illustration.
33. Route the kit harness alongside the main wire harness.
34. Locate and disconnect the white 6 connector that plugs the engine harness into the chassis harness. Remove the dual yellow wire spade from the main wire harness connector.
35. Install the single terminal housing (PN 4020140) from the kit on this yellow wire. Attach the housing and wire onto the male connector from the kit harness.

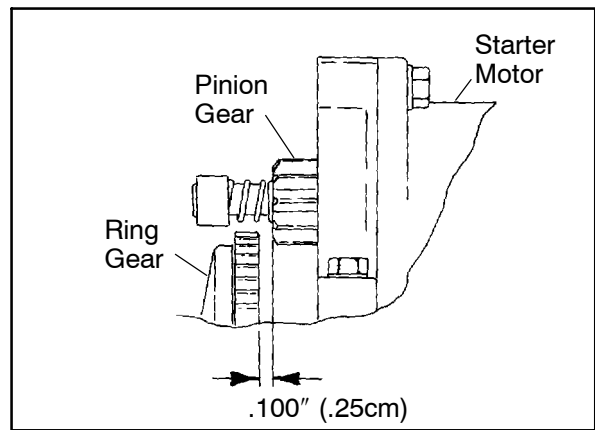

Steps 18. - 19.

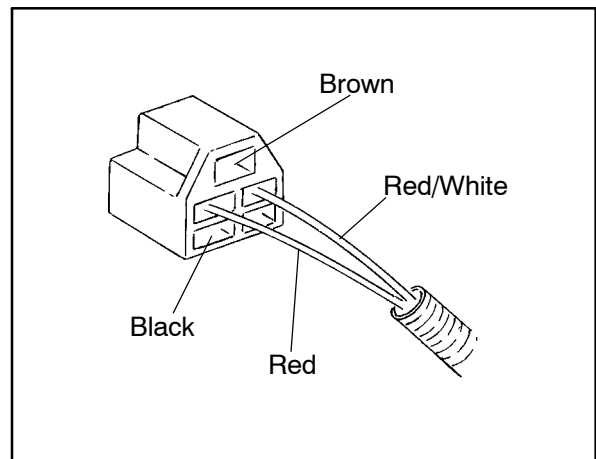

Step 29.

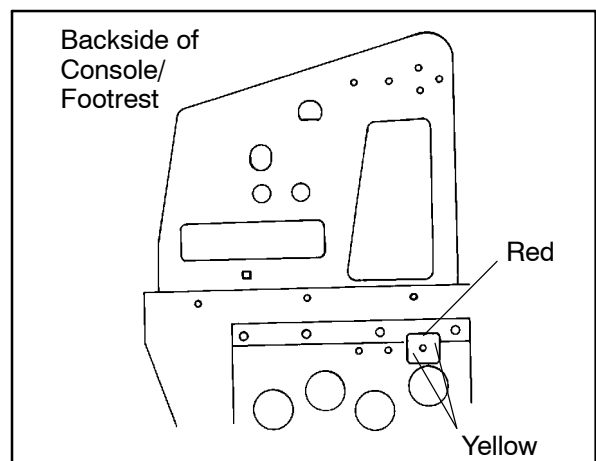

Steps 24. , 31. , 32.

36. Install the single spade connector from the kit harness into the terminal the yellow wire was removed from. **NOTE:** This spade connector must align with the jumper wire at the engine connector.
37. Secure the wire harness with cable ties (PN 7080138) and route to the front left corner of the snowmobile.
38. Install the starter motor solenoid (PN 3083211) to the battery box studs. Secure with flat washers (PN 7558203) and 10-24 lock nuts (PN 7541925).
39. Install circuit breaker (PN 2434008) into holes above studs using 10-24 x 5/8" screw (PN 7511989) and lock nut (PN 7541925).
40. Insert battery pads (PN 5810508) into battery box; two on left side, two on bottom, one on front side and one on right side.

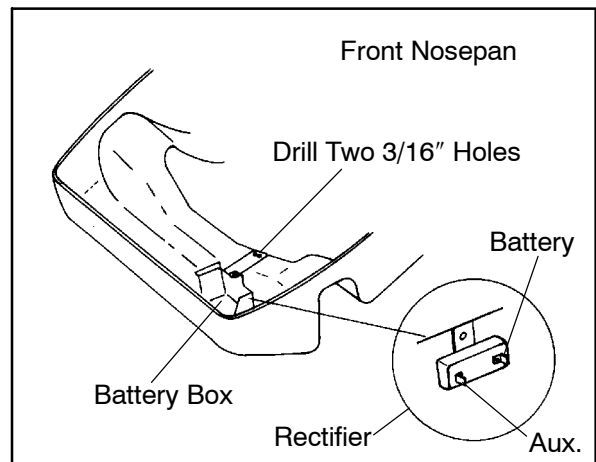

Step 42.

41. Set battery box in front left corner of nose pan so the rear bracket lays flat on the bulkhead and the bulkhead rivet is between the two holes in the bracket. **NOTE:** If installing this kit in a unit with a skid plate, it will be necessary to remove the skid plate.
42. Using the bracket as a template, drill two 1/8" holes in the bulkhead. Secure bracket using 10-16 x 5/8" screws (PN 7512009). See Illustration.
43. Pushing down on the battery box, drill a 3/16" hole from the outside of the pan through the pan and battery box bottom. Secure with rivet (PN 7621472). Repeat process for the other three rivets.
44. Install the cable from the starter to the solenoid.
45. Install the 7" battery cable (PN 2460393) to the other stud of the solenoid.
46. Install the small red wire from the solenoid to the battery side of the circuit breaker.
47. Connect the bullet terminal from the electric start harness to the bullet connector on the solenoid.
48. Connect the spade connector on the electric start harness to the open connector on the circuit breaker.
49. Install the battery with the terminals toward the back of the machine.
50. Connect the red battery cable to the positive terminal.
51. Connect the remaining end of the battery ground cable (from Step 15.) to the negative battery post and tighten. **CAUTION:** To avoid the possibility of explosion, always connect the black ground cable last. When removing the battery, remove the black ground cable first.
52. Attach the battery hold down strap to the tabs provided on the battery box.
53. Locate drain hole on left side of bulkhead and remove plug for battery vent line. Insert tube so that 1/8" of the tube sticks out through the bottom of the belly pan. **NOTE:** If installing this kit in an XCR 440 or XCR 600, hold the skid plate in place and drill for the vent line. Set skid plate aside.
54. Install one end of battery vent tube into the stand pipe and the other end through the drain hole in the bulkhead. Install open/close bushing (PN 7080399) from bottom of bulkhead. (*XCR 440 and XCR 600 models: reinstall skid plate. Leave 1/8" (.3 cm) of vent tube protruding through the skid plate.*) Cut any excess vent tubing which may hang below the bulkhead. **CAUTION:** Check the vent tube to be sure it is open and not kinked or pinched. A kinked or pinched vent tube will allow battery gases to accumulate, which could result in an explosion.
55. Reinstall the muffler that was removed in step 7.
56. Insert key and test the electric start. If the starter doesn't function, re-check the wiring.

Instruction PN 9913971 Rev 02 2/97

Printed in USA

Use the following guide to help identify fasteners included with this kit. Parts are drawn to scale.

Bolts and Screws:

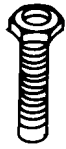

7511930



7512009

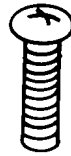

7511989

Nuts:

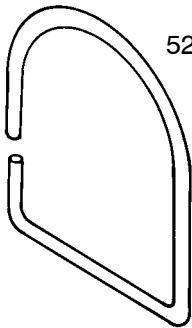

5224468



7541925

Washers:

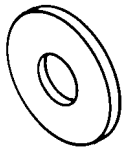

7555734



7558203



7080399

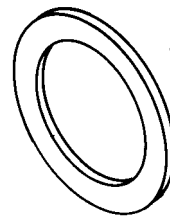

7556509

Rivets:

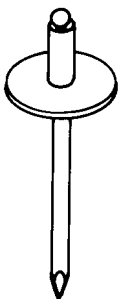

7621472

Cable Ties:



7080138