

REAR NET KIT



P/N 2881915

APPLICATION

GEM E2, E4, and E6

BEFORE YOU BEGIN

Read these instructions and check to be sure all parts and tools are accounted for. Please retain these installation instructions for future reference and parts ordering information.

KIT CONTENTS

This Kit includes:

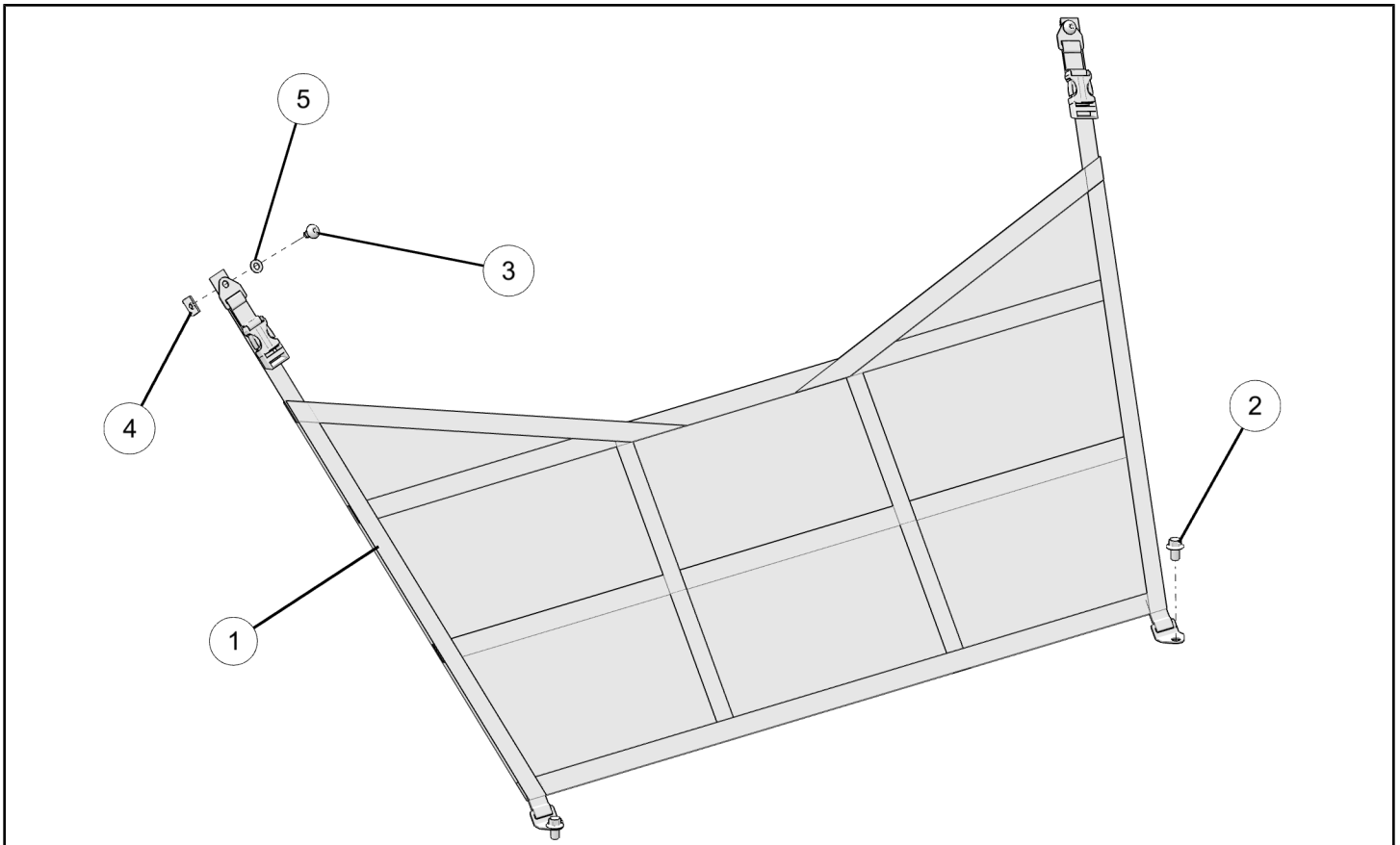

REF	QTY	PART DESCRIPTION	PART NUMBER
1	1	Rear Net	2687246
2	2	Screw - M10 X 1.5 X 16	7517951
3	2	Screw - M8 X 1.25 X 15	7520391
4	2	Roll-In Nut - M8 X 1.25	7547806
5	2	Washer - 8.4 X 16 X 1.6	7556305
	1	Instructions	9927038

TOOLS REQUIRED

- Flat Head Screwdriver
- Torque Wrench

- 13mm Socket
- T40 Torx® Socket

IMPORTANT

Your REAR NET KIT is exclusively designed for your vehicle. Please read the installation instructions thoroughly before beginning. Installation is easier if the vehicle is clean and free of debris. For your safety, and to ensure a satisfactory installation, perform all installation steps correctly in the sequence shown.

ASSEMBLY TIME

Approximately 15 minutes

INSTALLATION INSTRUCTIONS

1. Place vehicle in "PARK". Turn key to "OFF" position and remove from vehicle.
2. Remove two darts (A) from rear of the vehicle.

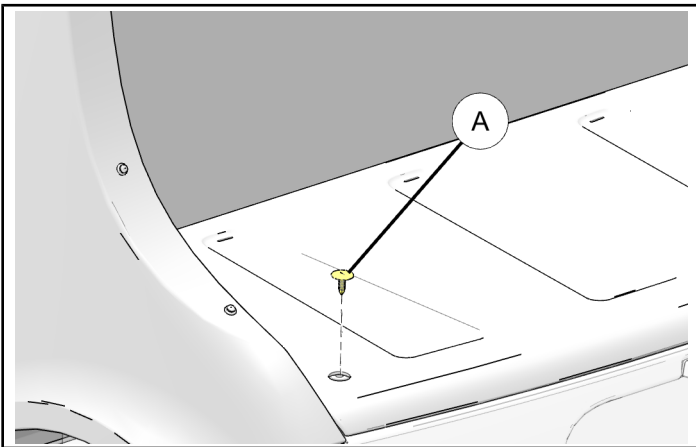

3. Align bottom of net ① with holes in rear of the vehicle and install screws ②. Use 13mm socket and torque wrench for tightening. Torque screws to specification.

TORQUE

38 ft. lbs. (51.5 Nm)

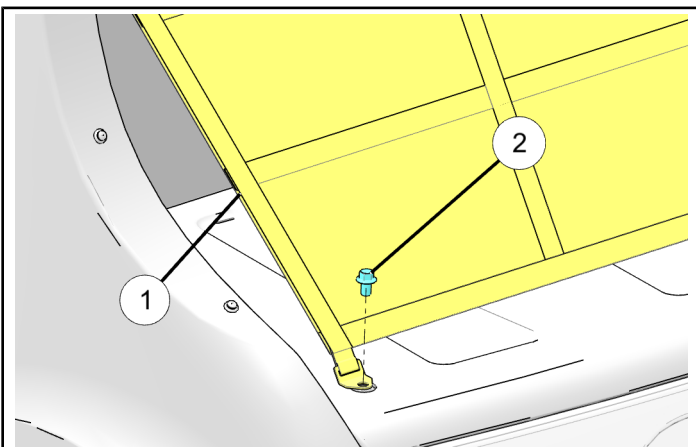

4. Install roll-in nuts ④ into OPS T-slot. Use flat head screwdriver underneath to prevent nut from sliding out and to ensure nut is centered in the T-slot. Install net using screws ③ and washers ⑤. Use T40 socket and torque wrench for tightening. Torque screws to specification.

TORQUE

18 ft. lbs. (24.4 Nm)

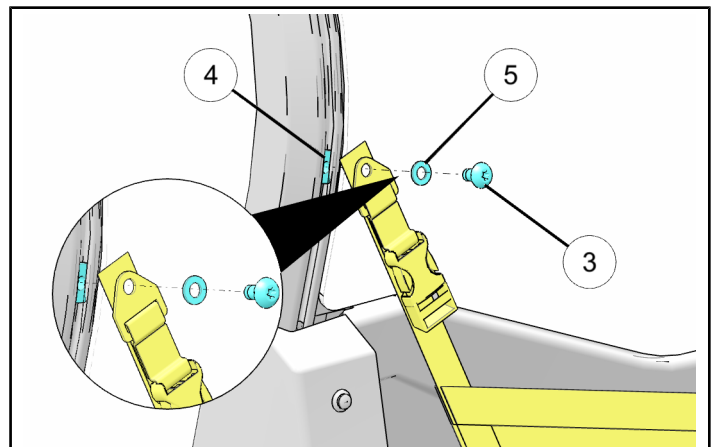

5. Adjust rear net straps (B) as required.

