

FLOOR MAT KIT



P/N 2882555, 2882556, 2882557

APPLICATION

E2 / eL XD (PN 2882555), E4 (PN 2882556), E6 (PN 2882557)

BEFORE YOU BEGIN

Read these instructions and check to be sure all parts and tools are accounted for. Please retain these installation instructions for future reference and parts ordering information.

KIT CONTENTS

Kit PN 2882555 includes:

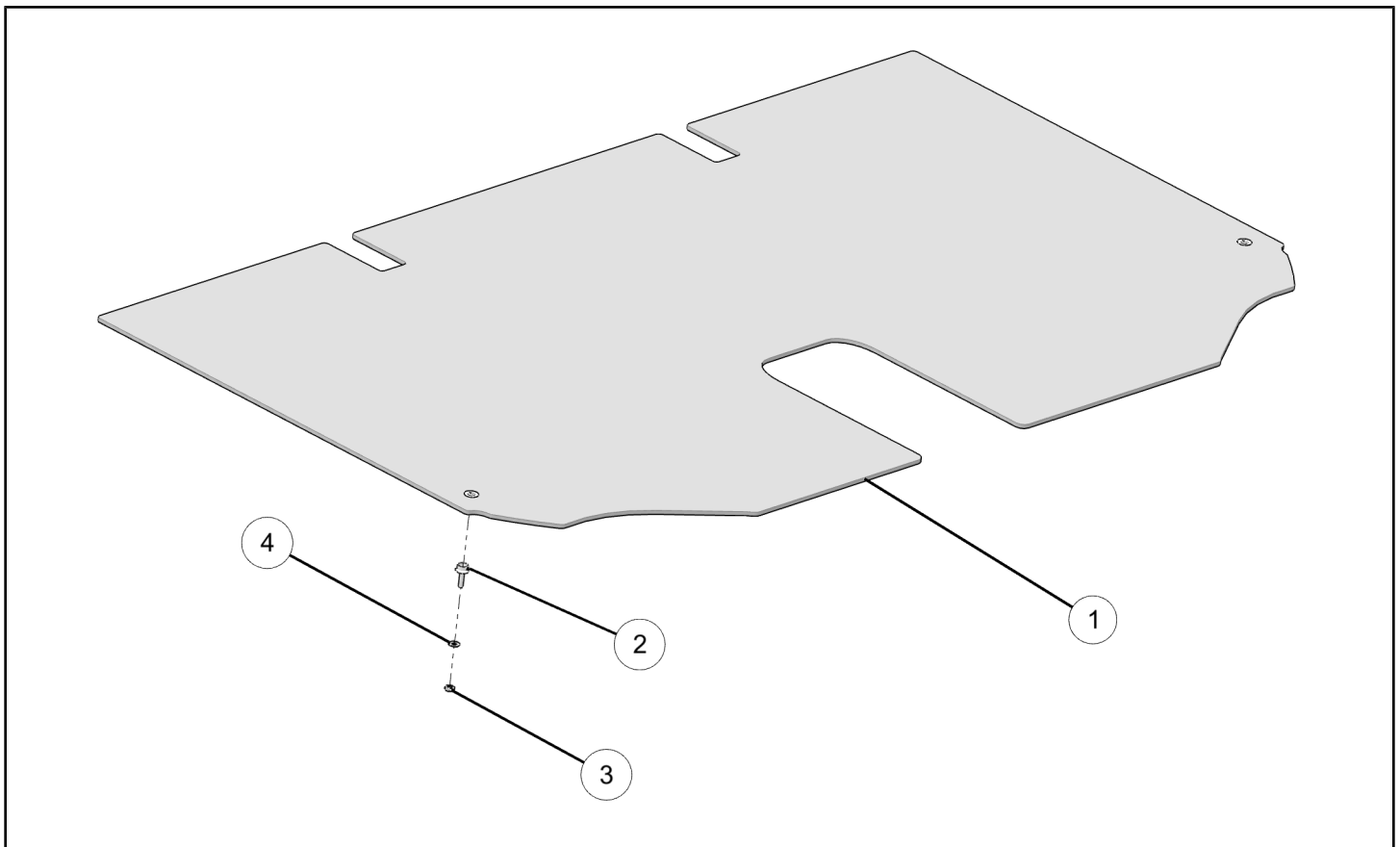

REF	QTY	PART DESCRIPTION	PART NUMBER
1	1	Front Floor Mat	2687592
2	2	Snap Stud, 8 - 32	7520402
3	2	Nut, 8 - 32	7541915
4	2	Washer 11/64 X 3/8 X 1/32	7555727
	1	Instructions	9927831

Kit PN 2882556 includes:

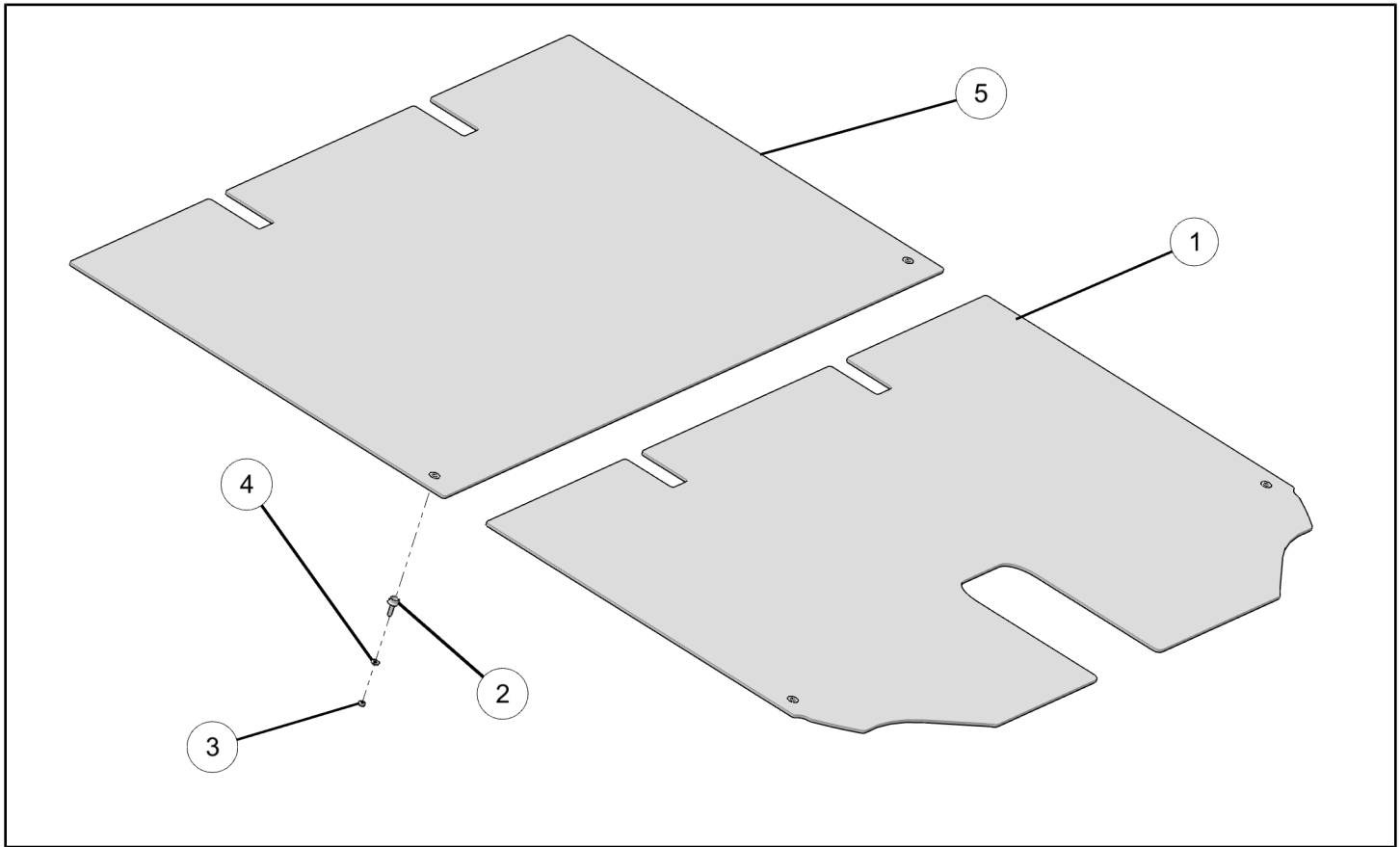

REF	QTY	PART DESCRIPTION	PART NUMBER
1	1	Front Floor Mat	2687592
2	4	Snap Stud, 8 - 32	7520402
3	4	Nut, 8 - 32	7541915
4	4	Washer 11/64 X 3/8 X 1/32	7555727
5	1	Rear Floor Mat	2687593
	1	Instructions	9927831

Kit PN 2882557 includes:

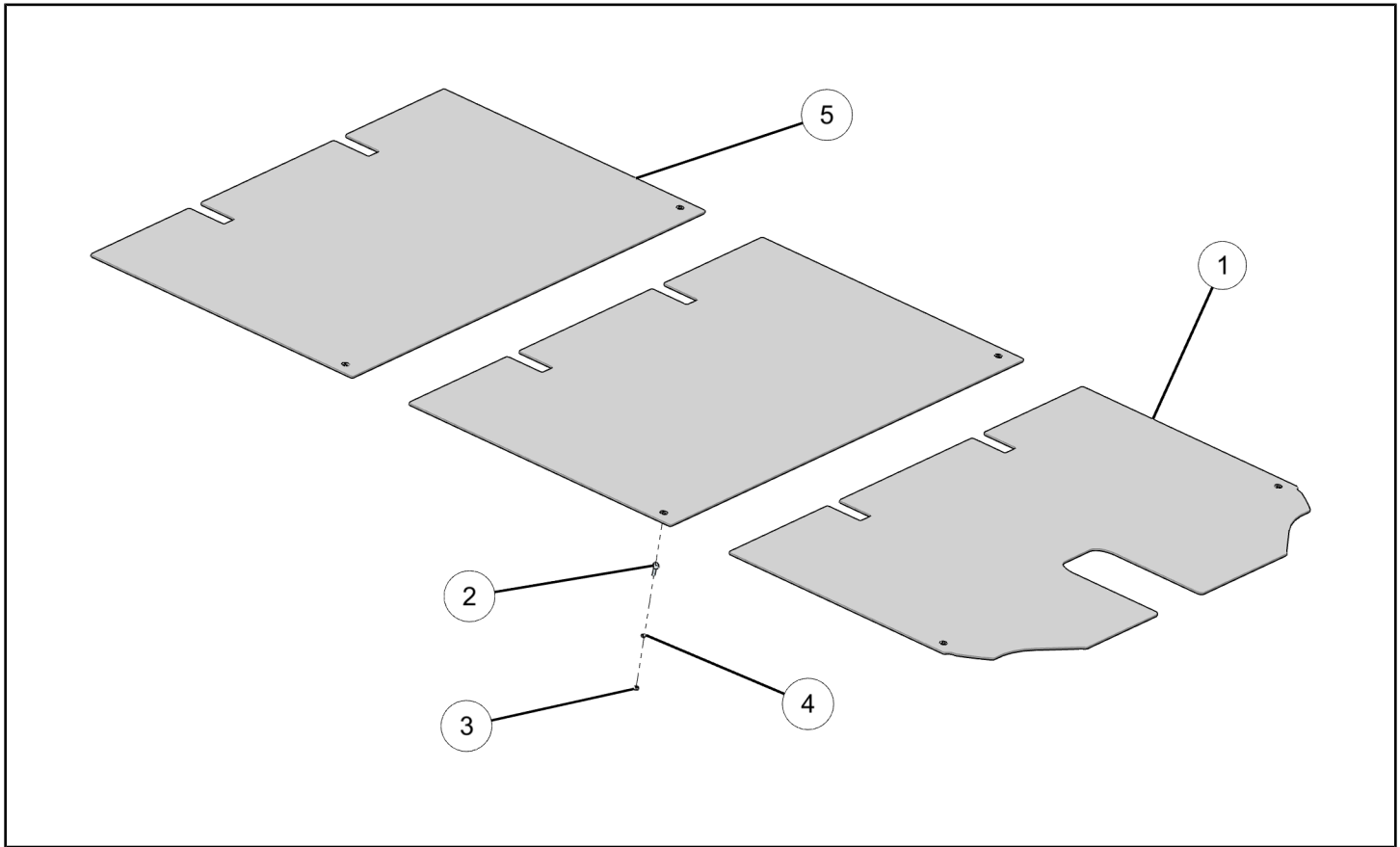

REF	QTY	PART DESCRIPTION	PART NUMBER
1	1	Front Floor Mat	2687592
2	6	Snap Stud, 8 - 32	7520402
3	6	Nut, 8 - 32	7541915
4	6	Washer 11/64 X 3/8 X 1/32	7555727
5	2	Rear Floor Mat	2687593
	1	Instructions	9927831

TOOLS REQUIRED

- Philips Screw Driver
- 8/32" Socket
- Ratchet

IMPORTANT

Your FLOOR MAT KIT is exclusively designed for your vehicle. Please read the installation instructions thoroughly before beginning. Installation is easier if the vehicle is clean and free of debris. For your safety, and to ensure a satisfactory installation, perform all installation steps correctly in the sequence shown.

ASSEMBLY TIME

Approximately 15 minutes

INSTALLATION INSTRUCTIONS

1. Place vehicle in "PARK". Turn key to "OFF" position and remove from vehicle.
2. Locate small holes (B) in floor (A) for mat installation. Holes in floor may be easier to find by looking underneath the vehicle. Below image shows four hole locations for mat installation in E4 models. E2 /eL XD will have two holes and E6 will have six holes in the floor.

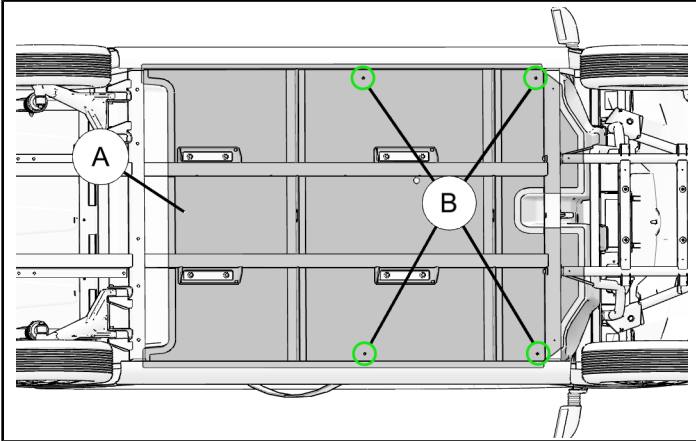

4. Install floor mats ① and ⑤ on floor (A) and secure by engaging the snaps studs installed in Step 3.

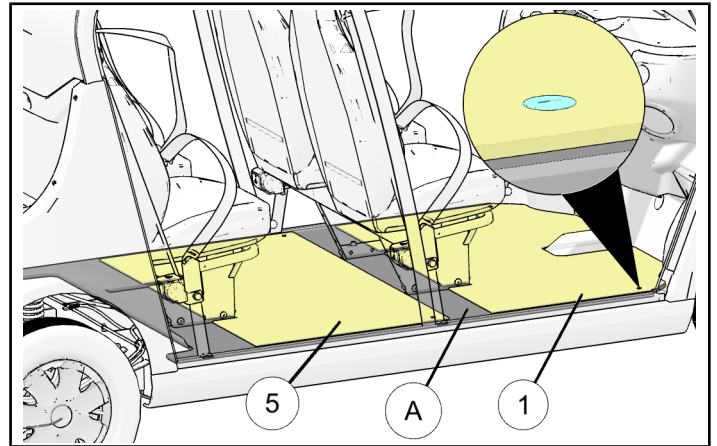

3. Install snap stud ②, washer ④, and nut ③ into the floor. Tighten nut using Phillips screw driver and socket and ratchet. Torque nut to below specification.

TORQUE

2 lb-ft (2.7 Nm)

IMPORTANT

Do not overtighten nut as this may cause the washer to embed in the floor material.

