

Lock n' Ride Cab Windshield

KIT PN 2879108

Application Polaris RGM/RGMC



Before you begin, read these instructions and check to be sure all parts and tools are accounted for. Please retain these installation instructions for future reference and parts ordering information.

Kit Components:

<u>QTY.</u>	<u>Part Description</u>
1	Windshield
12	Torx Screw
4	Full Snap Clamp
2	Half Snap Clamp
5ft	Adhesive Foam Seal

IMPORTANT: Your Polaris accessory kit is exclusively designed for your Polaris vehicle. Please read the installation instructions and operator's manual thoroughly before beginning. Installation of any item is easier if the vehicle is clean and free of debris.

Approximate Installation Time: 5 Minutes

INSTALLATION INSTRUCTIONS:

1. Install (4) full snap clamps in the side mount locations of the windshield using (8) torx screws.
2. Install (2) half snap clamps in the top mount locations of the windshield using (4) torx screws.
3. Align the assembled windshield with the front cab frame of the vehicle. Once all clamps have been aligned with the frame bars, press down on each clamp to snap into place.
4. If you are installing the cab roof, apply the adhesive foam seal to the roof where it meets the top of the windshield. This is meant to seal the gap between the windshield and roof.
5. Tighten all hardware.

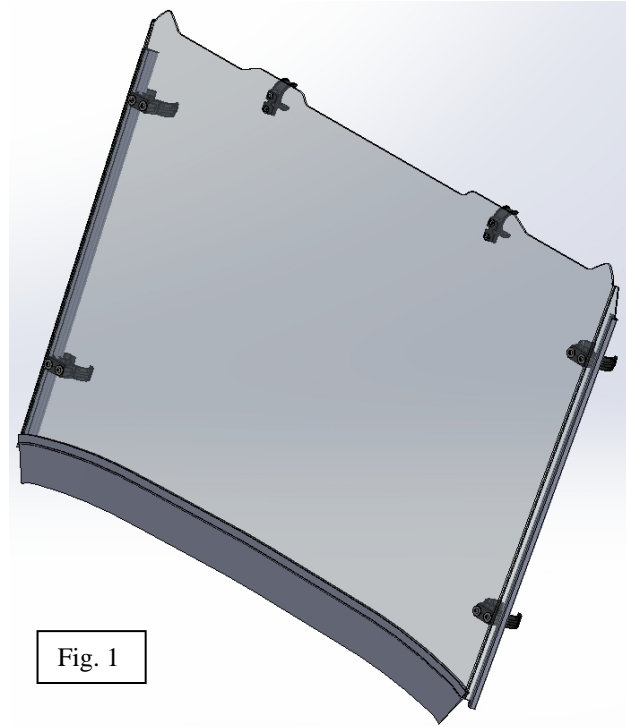

IMPORTANT: Do not use glass cleaners and solvents such as ammonia, alcohol, and petroleum distillates.

Cleaning:

1. Use an indirect high pressure water supply to rinse the large dirt particles from the windshield.
2. Once the majority of dirt is removed, use warm soapy water and a cotton terry cloth to wash all windshield components.
3. Rinse thoroughly and allow to air dry.

Use a quality polish such as Plexus® or Novus II® to clean and remove fine scratches from the windshield