

# PLOW ANGLE KIT



**P/N 2883409**

## APPLICATION

Verify accessory fitment at [Polaris.com](http://Polaris.com).

## BEFORE YOU BEGIN

Read these instructions and check to be sure all parts and tools are accounted for. Please retain these installation instructions for future reference and parts ordering information.

## KIT CONTENTS

This kit contains parts for installation of the plow angle cylinder only. Prior installation of the following additional kits is also required (sold separately):

- Plow system (frame, lift method, and blade)
- Plow Controller Kit, PN 2883247 (or equivalent)

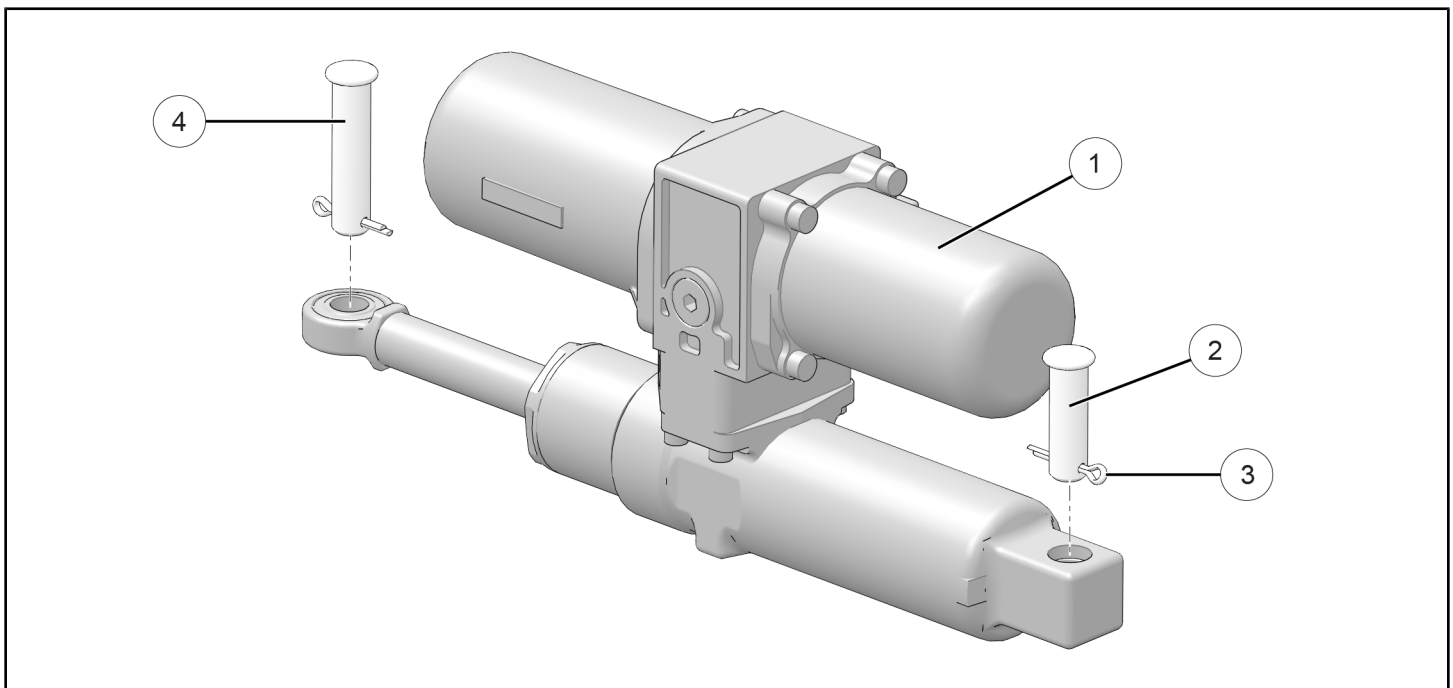

REF	QTY	PART DESCRIPTION	PART NUMBER
1	1	Cylinder, Plow Angle	-
2*	1	Pin, Clevis - 14 X 54	-
3*	2	Cotter Pin - 3 X 25	-
4*	1	Pin, Clevis - 14 X 78	-
5	2	Cable Tie (not shown)	7080492
	1	Instructions	9928734

Items marked (\*) are included in Hardware Kit PN 2204892.

## TOOLS REQUIRED

- Safety Glasses
- Pliers, Slip Joint

## IMPORTANT

Your Plow Angle Kit is exclusively designed for your vehicle. Please read the installation instructions thoroughly before beginning. Installation is easier if the vehicle is clean and free of debris. For your safety, and to ensure a satisfactory installation, perform all installation steps correctly in the sequence shown.

## INSTALLATION INSTRUCTIONS

1. Shift vehicle transmission into "PARK". Turn ignition switch to "OFF" position and remove key.

### CAUTION

Manual angle adjustment mechanism is heavy. Support mechanism as required during removal to prevent injury.

2. Remove two cotter pins (A), then remove clevis pins (B) and (C) from each end of manual angle adjustment mechanism.

Carefully slide mechanism out of plow frame brackets, then set aside. Existing pins will not be reused for installation of angle cylinder (1).

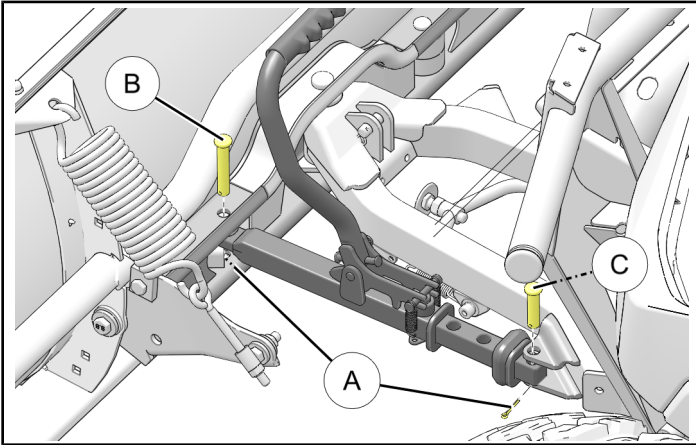

3. Install rear end of angle cylinder (1) to plow frame brackets using 54 mm clevis pin (2) and new cotter pin (3).

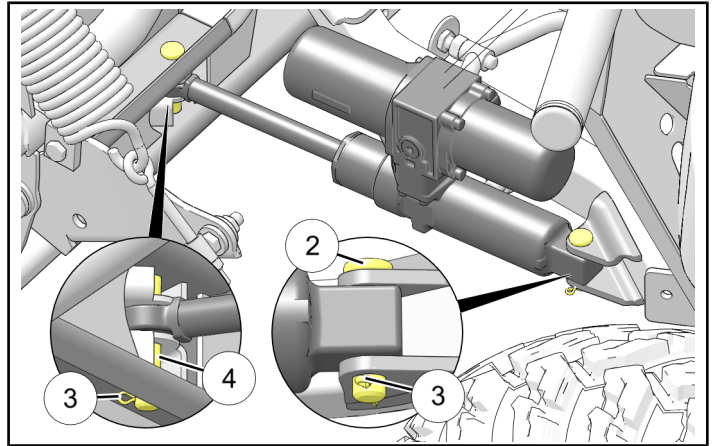
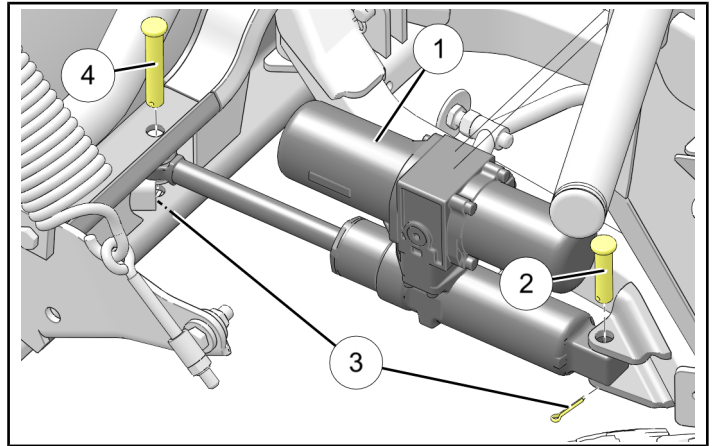

4. Join connector from angle cylinder (1) to mating TILT connector from Plow Controller Kit (PN 2883247 or equivalent, sold separately).

### NOTE

See Plow Controller Kit instructions for details.

5. Turn ignition switch to "ACC" position. Lift blade off ground high enough to manually swing blade right and left, then turn ignition switch to "OFF" position and remove key.

6. Swing blade into rod end fitting on front of angle cylinder ①, then secure using 78 mm clevis pin ④ and new cotter pin ③. See previous Step 3 for illustration.
7. Secure angle cylinder ① harness using two cable ties ⑤ to prevent contact with sharp edges or moving parts.
8. Turn ignition switch to “ACC” position, lower blade, then turn ignition switch to “OFF” position and remove key.

## FEEDBACK FORM

A feedback form has been created for the installer to provide any comments, questions or concerns about the installation instructions. The form is viewable on mobile devices by scanning the QR code or by clicking [HERE](#) if viewing on a PC.

