

# BILLET DRIVER FLOORBOARD KIT



**P/N 2883021-156, 2883021-468**

## APPLICATION

2014 or Newer Indian Motorcycles with Thunderstroke 111

## BEFORE YOU BEGIN

Read these instructions and check to be sure all parts and tools are accounted for. Please retain these installation instructions for future reference and parts ordering information.

## KIT CONTENTS

This Kit includes:

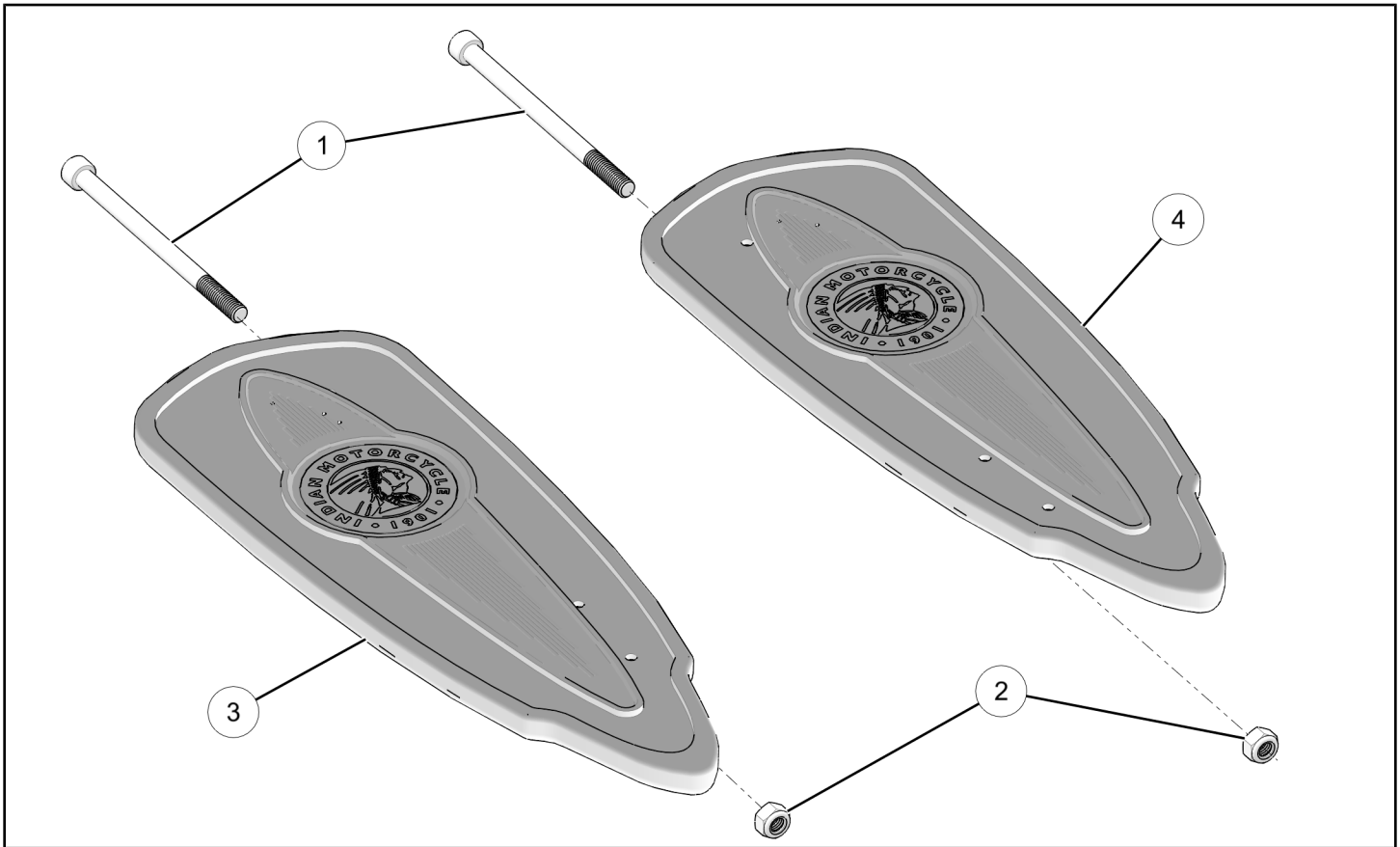

REF	QTY	PART DESCRIPTION	PART NUMBER
1	2	Bolt, Socket Head, M8 X 1.25 X 120	7520699
2	2	Nut, Nylon Locking, M8 X 1.25	7547673
3	1	Floorboard, Driver, Ness, 16, LH, Chrome Floorboard, Driver, Ness, 16, LH, Anodized Black	5141513-156 5141513-468
4	1	Floorboard, Driver, Ness, 16, RH, Chrome Floorboard, Driver, Ness, 16, RH, Anodized Black	5141514-156 5141514-468
	1	Instructions	9925846

## TOOLS REQUIRED

- Safety Glasses
- Socket Set, Hex Bit, Metric
- Socket Set, Metric
- Torque Wrench
- Wrench Set, Metric

## IMPORTANT

Your Indian Billet Driver Floorboard Kit is exclusively designed for your vehicle. Please read the installation instructions thoroughly before beginning. Installation is easier if the vehicle is clean and free of debris. For your safety, and to ensure a satisfactory installation, perform all installation steps correctly in the sequence shown.

## ASSEMBLY TIME

Approximately 24 minutes

## INSTALLATION INSTRUCTIONS

1. Turn key or ignition switch to “OFF” position and remove key. If equipped with keyless fob, remove fob from proximity of vehicle.
2. Ensure motorcycle is parked on a flat surface, kickstand is fully extended, and vehicle is stable prior to installation.

## REMOVAL

1. Remove bolt (A) and nut (B) from under floorboard and remove floorboard. Retain two spacers (C) for installation.

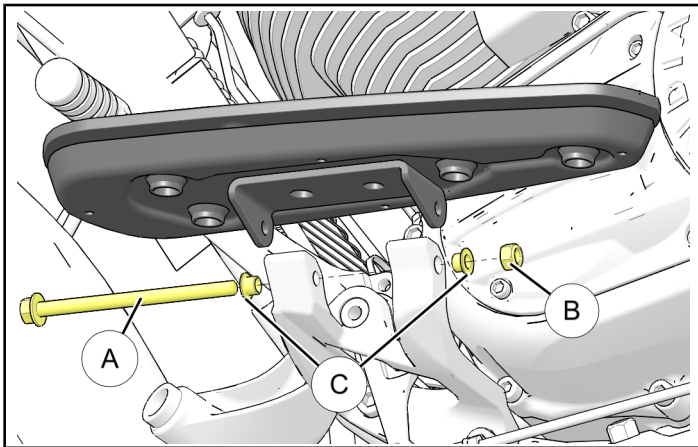

## FEEDBACK FORM

A feedback form has been created for the installer to provide any comments, questions or concerns about the installation instructions. The form is viewable on mobile devices by scanning the QR code or by clicking [HERE](#) if viewing on a PC.

## INSTALLATION

1. Ensure bushings (C) are in place and place new LH floorboard (3) on bracket. Install bolt (1) and nut (2). Torque fasteners to specification.

### TORQUE

18 ft. lbs. (24 Nm)

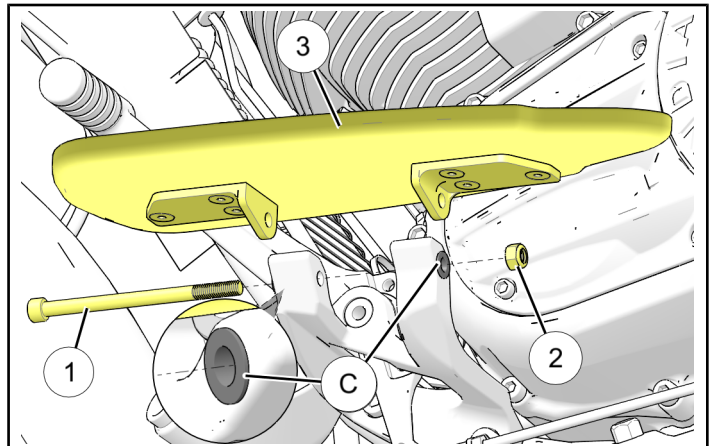

### FEEDBACK FORM

