

SCOUT® BOBBER CLUTCH CABLE AND ABS BRAKE LINE KIT



P/N 2884164

IMPORTANT

Due to the technical nature of this kit, Indian Motorcycle® insists this installation be performed by a certified Indian Motorcycle® Technician.

APPLICATION

Model Year 2019 and newer Indian® Scout® Bobber Models with ABS and Accessory Handlebars.

Verify accessory fitment at www.indianmotorcycle.com.

BEFORE YOU BEGIN

Read these instructions and check to be sure all parts and tools are accounted for. Please retain these installation instructions for future reference and parts ordering information.

REQUIRED SOLD SEPARATELY

This kit contains parts for installation of the Brake and Clutch Kit only. Prior installation of an accessory handlebar is required. See www.indianmotorcycle.com for details.

KIT CONTENTS

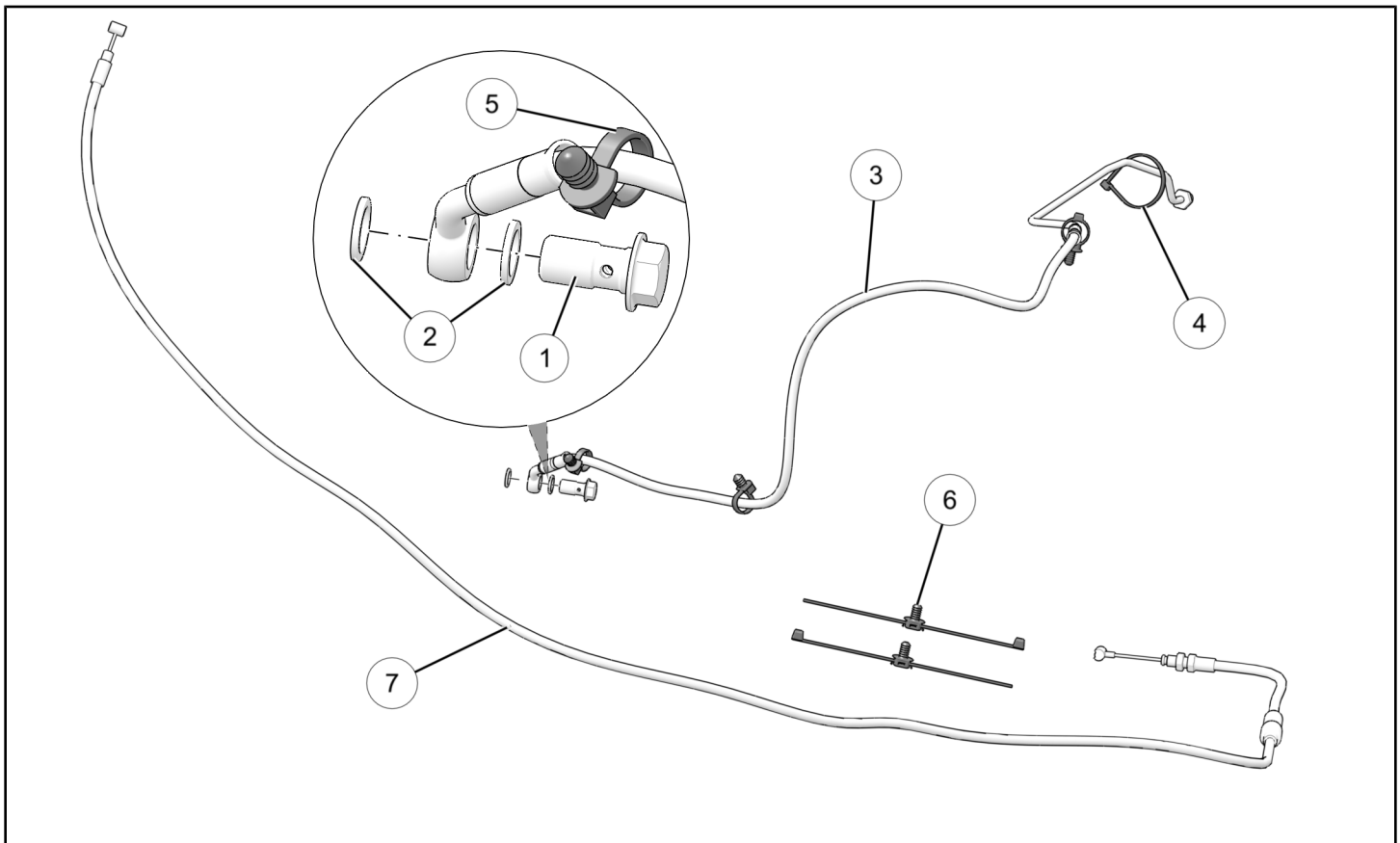

REF	QTY	PART DESCRIPTION	P/N AVAILABLE SEPARATELY
1	1	Banjo Bolt, 10mm X 1.25	1910958
2	2	Washer, Copper, M10	1912829
3	1	Brake Line, Front, Accessory, ABS	-
4	1	Cable Tie	7080138
5	2	Cable Tie, Push Pin	7081334
6	3	Routing Clip	7081496
7	1	Clutch Cable, 8mm, 17mm, Adjustable	7082203
	1	Instructions	9929609

TOOLS REQUIRED

- Safety Glasses
- Camera, Digital (Optional)
- Digital Wrench™
- Drain Pan
- Hex Key Set, Metric
- Platform Jack, Motorcycle
- Pliers, Locking
- Pliers, Push Pin Rivet
- Pliers, Side Cutting
- Scale, Hanging Spring
- Socket Set, Hex Bit, Metric
- Socket Set, Metric
- Torque Wrench
- Wrench Set, Metric
- **Special Service Tool:**
Brake Lever Reserve Inspection Tool PN: PV-50104
- **Special Service Tool:**
Fuel Tank Fitting Plug Tool PN: PV-50567

CONSUMABLES REQUIRED

- DOT 4 Brake Fluid
- Gloves, Chemical Resistant
- Grease, Multi-Purpose

IMPORTANT

Your Indian Motorcycle® Scout® Bobber Clutch Cable and ABS Brake Line Kit is exclusively designed for your vehicle. Please read the installation instructions thoroughly before beginning. Installation is easier if the vehicle is clean and free of debris. For your safety, and to ensure a satisfactory installation, perform all installation steps correctly in the sequence shown.

INSTALLATION INSTRUCTIONS

VEHICLE PREPARATION

GENERAL

NOTE

This kit is to be installed in conjunction with accessory handlebar kits.

1. Ensure motorcycle is parked on a flat surface, kickstand is fully extended, and vehicle is stable prior to installation.

2. Turn key or ignition switch to OFF position and remove key.
3. Remove and retain seat as per owner's manual.
4. Remove fuse block as per owner's manual.
5. Remove fuel tank as per owner's manual.

NACELLE REMOVAL

1. Remove and retain six screws (A) from rear of headlight nacelle. Remove and set aside headlight nacelle and two brackets.

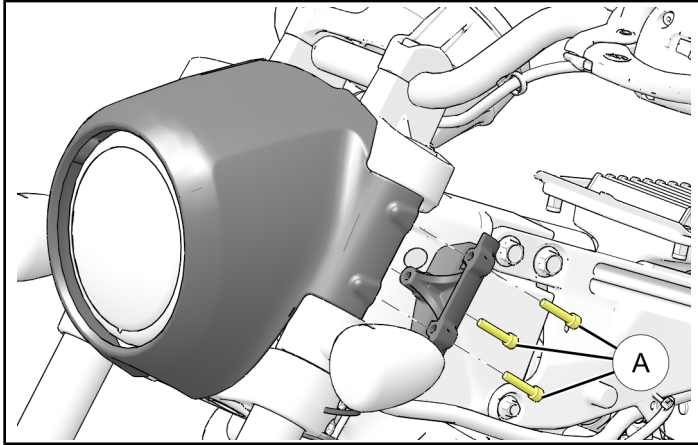

BRAKE LINE AND CLUTCH CABLE REMOVAL

BRAKE HARDLINE REMOVAL

CAUTION

Brake fluid is toxic and corrosive. Protect all motorcycle surfaces from brake fluid to prevent damage.

1. Remove and discard cable tie (A) and push pin cable tie (B) from brake line (C).

TIP

Take a photo of brake line routing to help ensure correct installation.

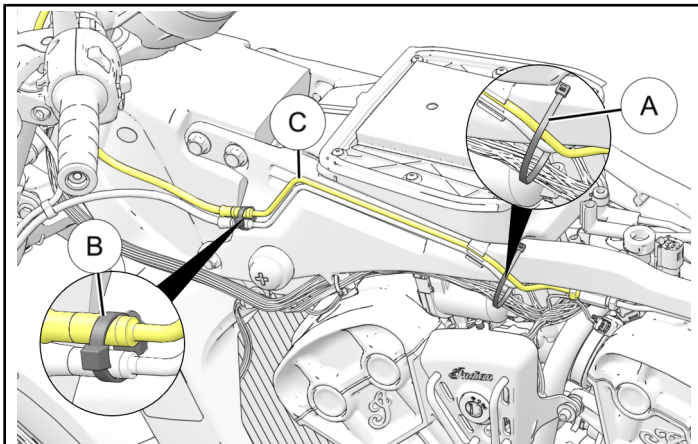

2. Remove and discard banjo bolt (D) and two seals (E) from upper end of front brake line (C) (Master Cylinder Fitting).

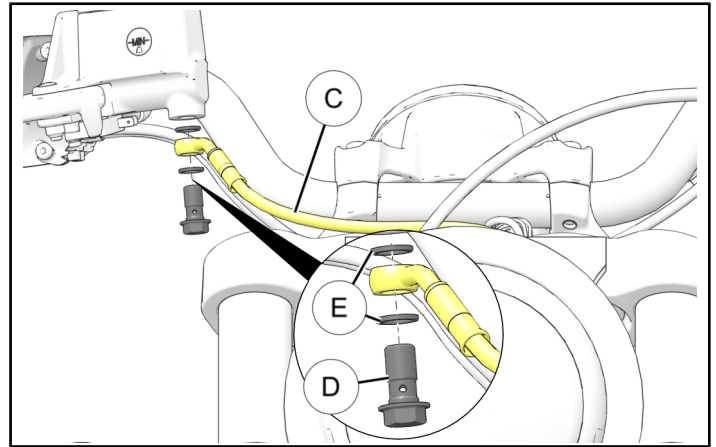

3. Disconnect flange fitting (F) from coupler nut (G). Unclip brake line (C) from frame clip (H). Remove brake line (C) from motorcycle and discard.

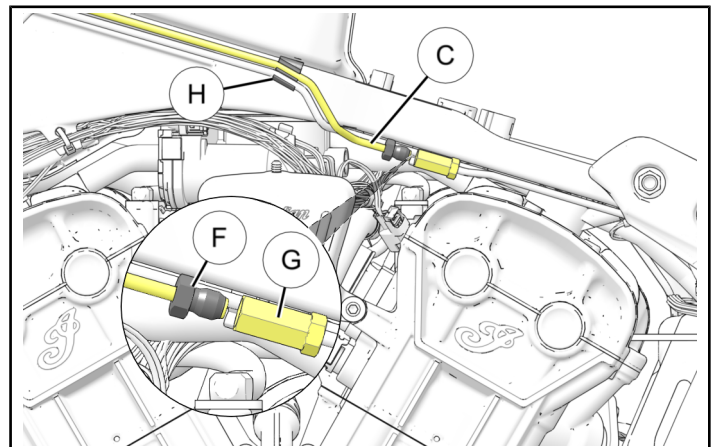

CLUTCH CABLE REMOVAL

1. Note location and remove and discard two cable ties (A) from clutch cable (B).

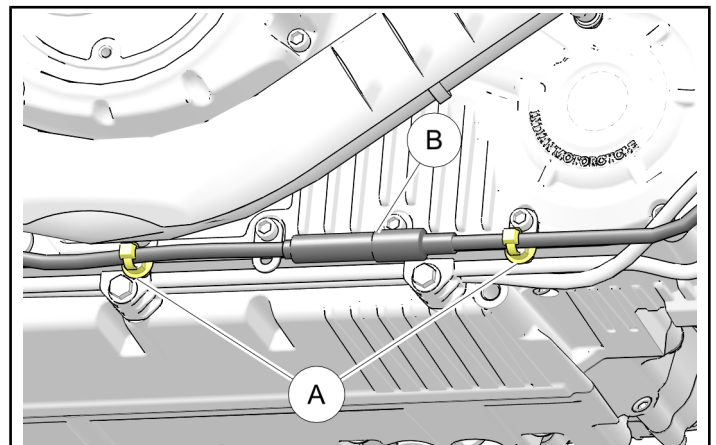

- Loosen nut ③ completely from clutch cable sleeve and slide up.

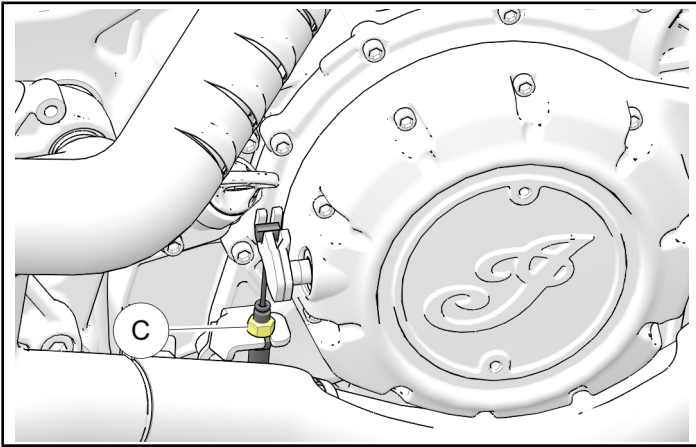

- Using a wrench, turn clutch arm ④ to release tension on cable ⑤. Remove cable end from clutch arm. Remove clutch cable ⑤ from bracket.

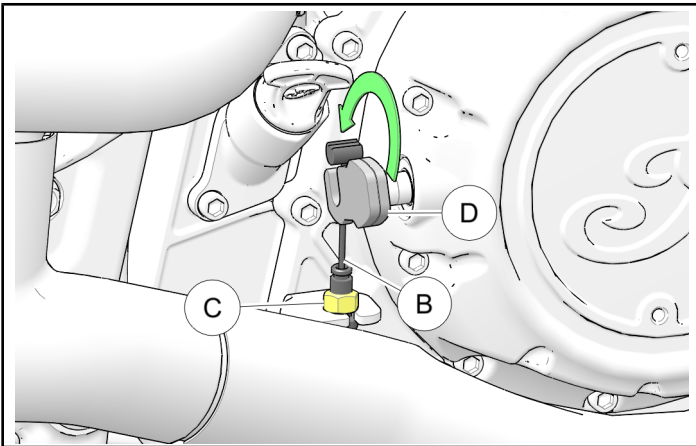

- Detach clutch cable ⑤ from motorcycle up to clutch handle ⑥ and remove stock clutch cable and discard.

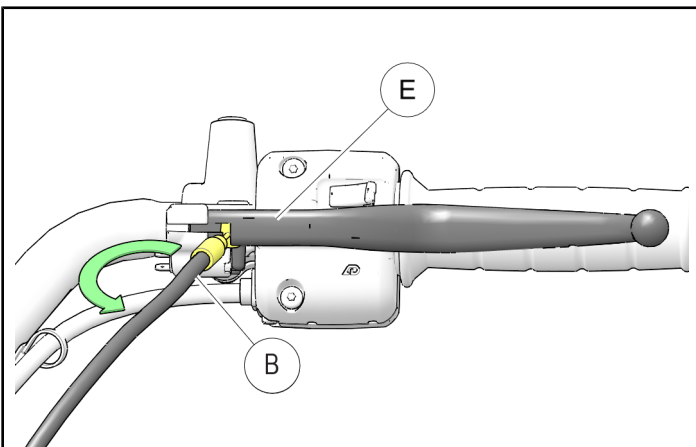

HANDLEBAR INSTALLATION

- Complete accessory handlebar installation before proceeding with **ABS Brake Line and Clutch Cable Installation** section.

ACCESSORY INSTALLATION

ABS BRAKE LINE INSTALLATION

- Route new front brake line ③ along path of original line and install flange fitting end to coupler nut ⑥. Clip brake line to frame clip ⑦. **DO NOT torque flange fitting at this time.**

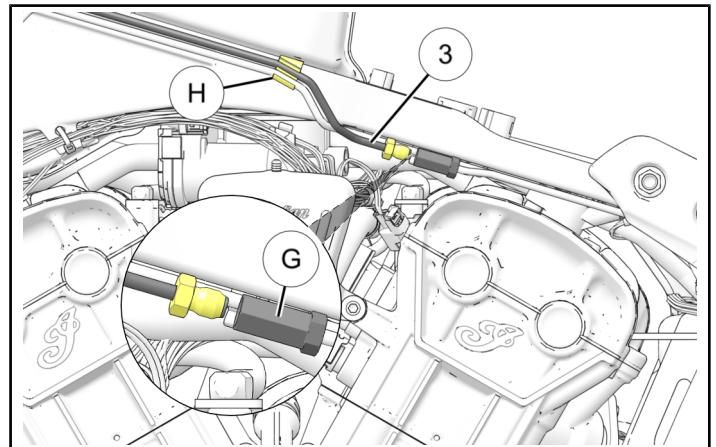

- Install new front brake line ③ to front master cylinder using one new banjo bolt ① and two new seals ②.

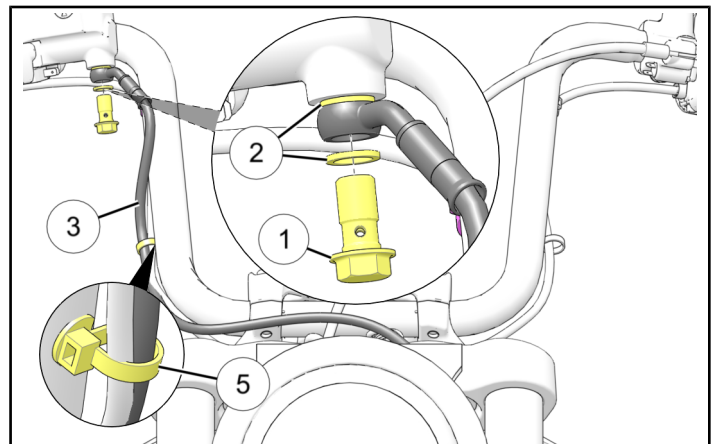

- Torque New brake line flange fitting and banjo bolt to specification.

TORQUE

Front Master Cylinder Banjo Bolt ①: **18 ft. lbs. (24 Nm)**

Front Brake Line ③ Flare Fitting: **13 ft. lbs. (17 Nm)**

- Secure brake line ③ to vehicle using push pin cable tie ⑤ and cable tie ④ in original locations as shown.

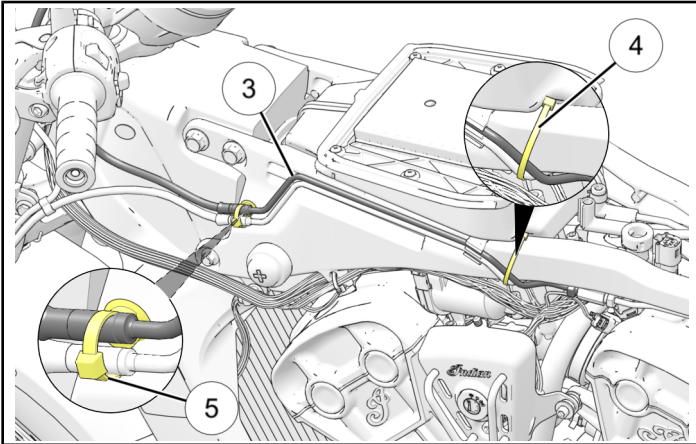

CLUTCH CABLE INSTALLATION

CAUTION

Do not kink, bend, or twist inner or outer cable casing during installation or clutch may bind.

- Route new clutch cable along same route as stock clutch cable except for nacelle location. Ensure clutch cable runs through center of wire retainer bracket.

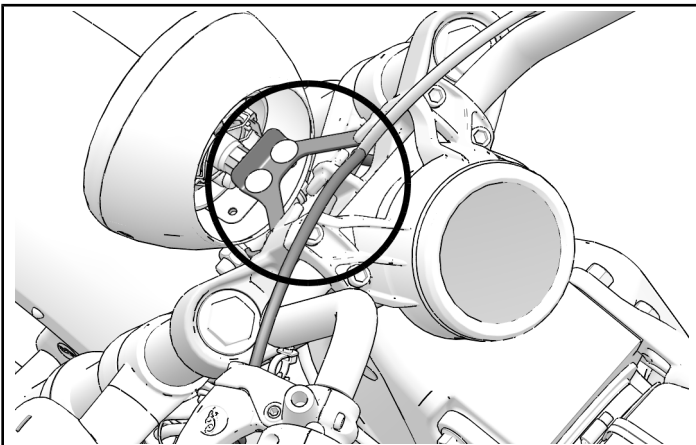

- Apply multi-purpose grease to lever end of new clutch cable ⑦ and install into clutch lever ⑥.

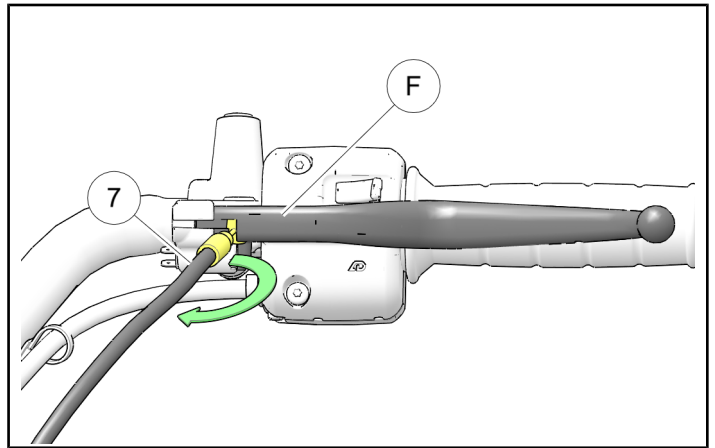

- Loosen jam nut ① on new clutch cable ⑦, apply multi-purpose grease to cable and install cable end into mounting bracket.

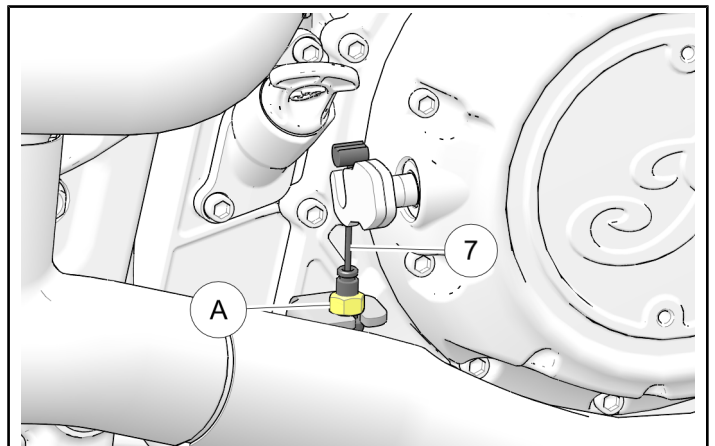

- Loosely thread jam nut ① onto cable to hold in place.
- Using a wrench, turn clutch arm ① to release tension and install cable end ⑦ into clutch arm.

NOTE

Ensure opposite end of clutch cable remains in clutch lever when performing this operation.

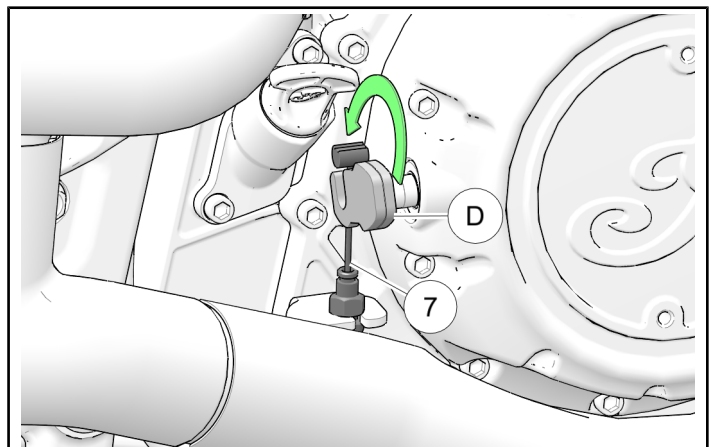

- Install two new cable ties (6) onto clutch cable (7) and attach to motorcycle. Ensure cable is routed outside of brake line to prevent clutch cable (7) binding.

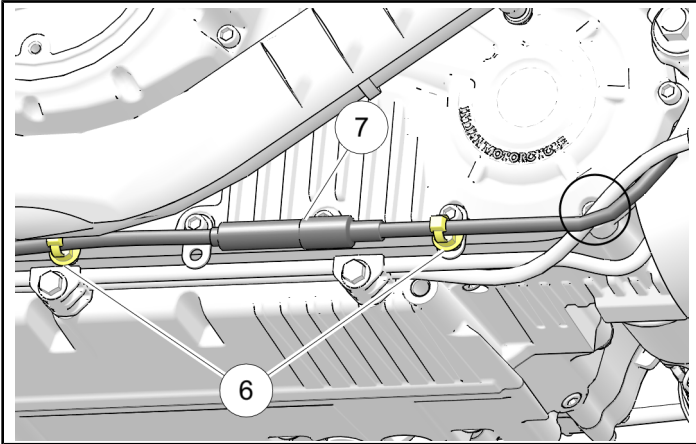

VEHICLE REASSEMBLY

GENERAL

- Reinstall headlight nacelle with six screws (A) and two brackets. Ensure turn signal wire harnesses are clear of nacelle and brackets when reinstalling.

TORQUE

Six screws (A): **84 in. lbs. (9.5 Nm)**

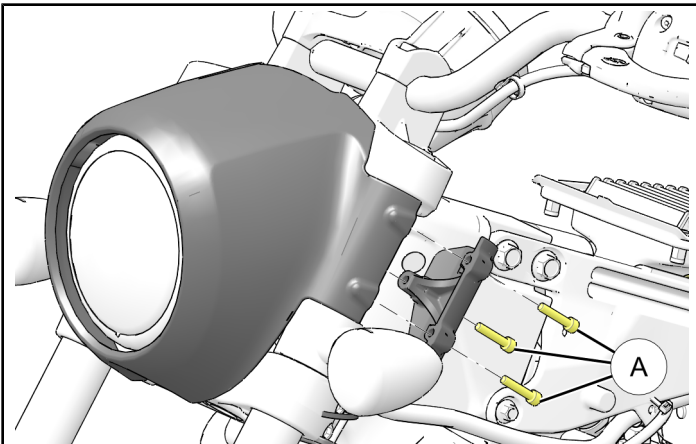

- Reinstall fuel tank as per owner's manual.
- Reinstall fuse block as per owner's manual.
- Reinstall seat as per owner's manual.
- Proceed with **Clutch Lever Free Play Adjustment** and **ABS Brake Bleeding** sections.

CLUTCH LEVER FREE PLAY ADJUSTMENT

- With handlebar pointing straight ahead, measure clutch lever free play at point shown, between lever and perch.

MEASUREMENT

Clutch Lever Free Play:
0.019 - 0.059 in. (0.5 - 1.5 mm)

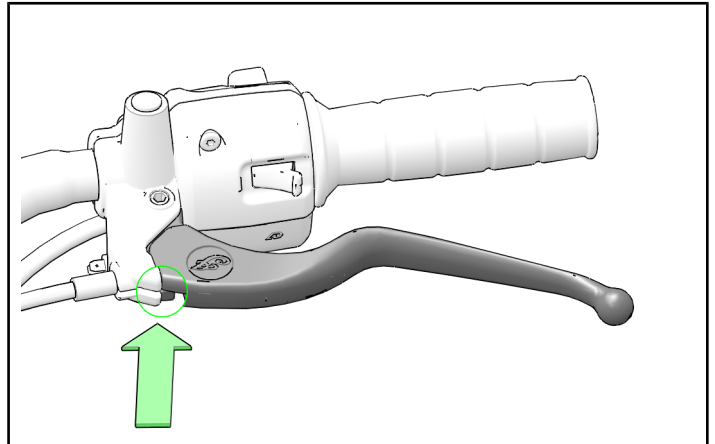

- Compare measurement to specification. If adjustment is needed, proceed to next step.
- Locate clutch cable adjuster boot (A) and pull it back to expose jam nut and barrel adjuster.

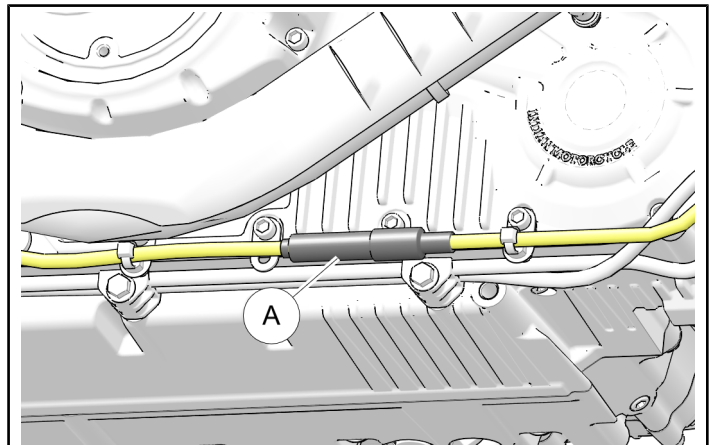

- Hold cable and loosen adjuster jam nut.
- Turn cable adjuster in or out until clutch free play is correct.
- Tighten adjuster jam nut to specification.

TORQUE

Jam nut: **48 in. lbs. (5 Nm)**

- Slide adjuster boot back over adjuster assembly.

ABS BRAKE BLEEDING

ABS FLUID CHANGE

Review Brake Fluid Replacement and Bleeding Precautions before working with brake fluid.

NOTE

When bleeding or flushing brake system, monitor fluid level in master cylinder reservoir constantly. **DO NOT** allow fluid level to fall below **LOW** level.

Use only DOT 4 brake fluid from sealed container.

NOTE

Flushing Brake System: Brake systems should be flushed every two years or more often if fluid is discolored. To flush brake system, follow normal brake bleeding process and pump fluid through brake system until fluid moving through bleeder hose is clear. Do not allow reservoir level to fall below **LOW** level or complete system bleeding will be required.

FRONT BRAKE BLEEDING

NOTE

A vacuum bleeder is recommended for system bleeding.

1. Remove and retain two screws (A) to remove front brake fluid reservoir cover (B) to add fluid as it is drawn through the brake system.

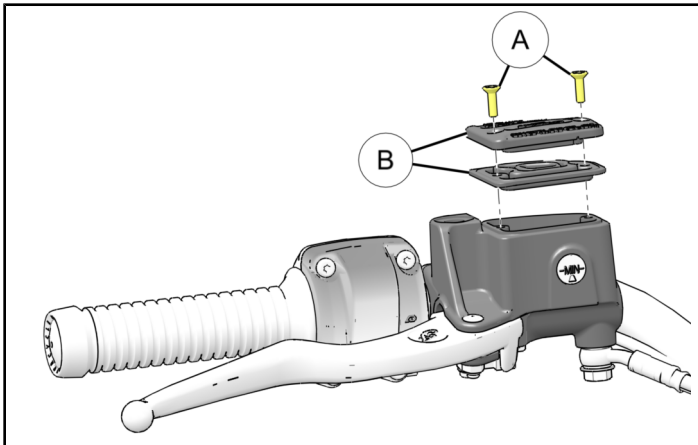

2. Remove rubber cap from bleeder screw (C) on front caliper and place wrench on screw.

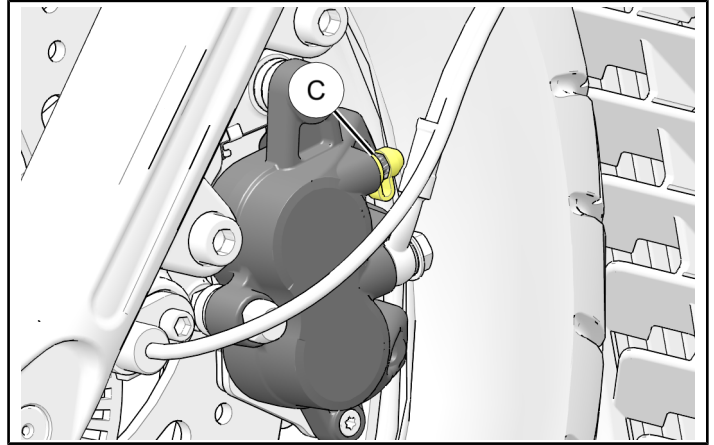

3. Attach tight fitting clear hose from vacuum bleeder to bleed screw and apply vacuum.
4. Hold lever to handlebar or hold firm pressure on lever, then open bleed screw about 1/4 turn while continuing to hold lever. Close bleeder screw while continuing to hold lever down. With bleeder screw closed, pump brake lever repeatedly with smooth full strokes until some resistance is felt.
5. Repeat **step 5** as necessary until brake lever feels firm. Ensure fluid reservoir does not become empty. Tighten bleeder screw.
6. Fill fluid reservoir and reinstall cover (B) with two cover screws (A).

TORQUE

Two cover screws (A): **13 in. lbs. (1.5 Nm)**

7. Perform Brake Lever Reserve Inspection.

BRAKE LEVER RESERVE INSPECTION

NOTICE

Indian Motorcycle® has approved two methods to ensure front brake circuit has been properly bled. Either method is acceptable.

1. While seated on stationary motorcycle, pull front brake lever with equivalent force necessary to activate ABS or bring motorcycle to an abrupt stop (~ 40 lbs. pull force). Brake lever should not contact grip.

OR, if PV-50104 is available

2. Place grommet of brake handle pressure tester **PV-50104** on ball end of front brake lever.

3. Connect scale (commercially available) with minimum of 25 kg / 50 lb capacity to end of tool.



4. Keep tool centered so it does not touch hand grip. Pull on scale connected to tool eyelet.

Brake Lever Reserve Force: 40 lbs (18 kg)

5. Have an assistant verify brake lever *does not* contact hand grip. Clearance must exist at specified reserve force.

6. If minimum brake lever reserve force is not met before lever makes contact with hand grip, brake system will need to be re-bled.

7. If the minimum force is unable to be met after system is inspected and re-bled, contact Technical Service at **1-800-330-9407**.

8. Test ride motorcycle to verify proper brake operation and pedal / lever feel.

FEEDBACK FORM

A feedback form has been created for the installer to provide any comments, questions or concerns about the installation instructions. The form is viewable on mobile devices by scanning the QR code or by clicking [HERE](#) if viewing on a PC.

FEEDBACK FORM

