

FOOT PEGS KIT BY ROLAND SANDS DESIGN®



P/N 2884096

INTERNATIONAL INSTRUCTIONS

DE DEUTSCH

Laden Sie die neuesten PDF-Anweisungen von www.indianmotorcycle.de herunter.

FR FRANÇAIS

Télécharger les dernières instructions en format PDF sur www.indianmotorcycle.fr.

IT ITALIANO

Scarica l'ultima versione delle istruzioni in formato PDF da www.indianmoto.it.

EN ENGLISH

Download the latest PDF instructions from www.indianmotorcycle.com.

ES ESPAÑOL

Descargue las instrucciones más recientes en formato PDF de www.indianmotorcycle.mx / www.indianmotorcycle.es.

ZH 中文

从www.indianmotorcycle.cn 下载最新的PDF说明。

1

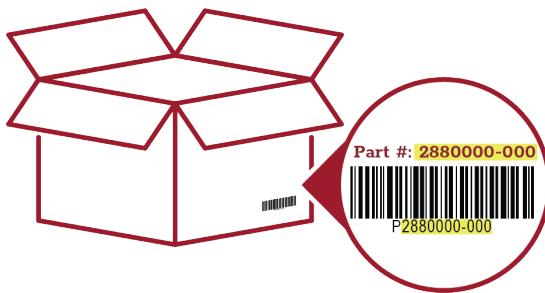

2



3



4



APPLICATION

Verify accessory fitment at www.indianmotorcycle.com.

BEFORE YOU BEGIN

Read these instructions and check to be sure all parts and tools are accounted for. Please retain these installation instructions for future reference and parts ordering information.

KIT CONTENTS

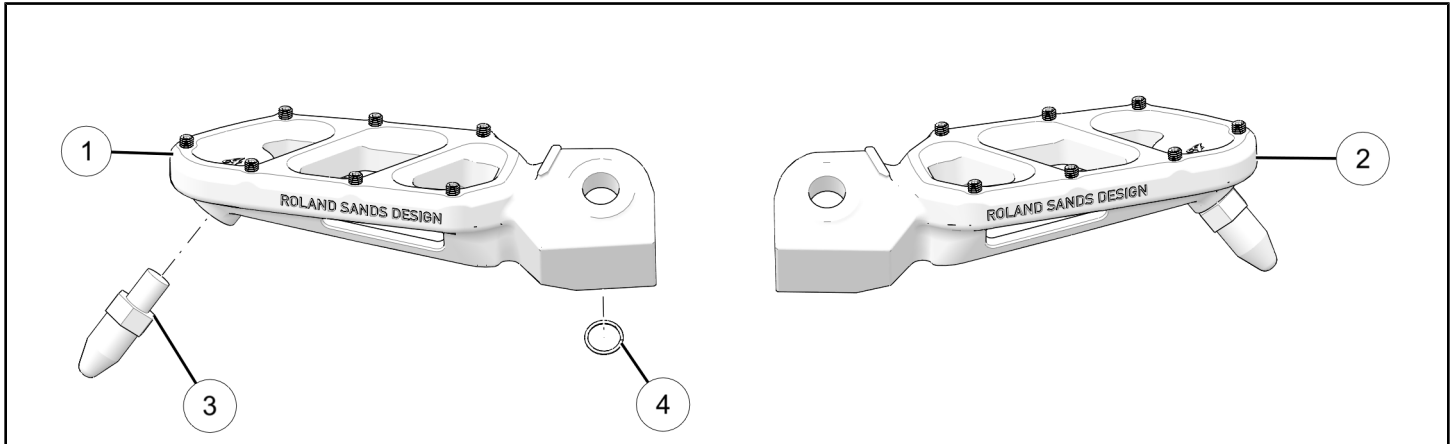

REF	QTY	PART DESCRIPTION	P/N AVAILABLE SEPARATELY
1	1	Peg-Foot, Driver, RH, Roland Sands Design®	n/a
2	1	Peg-Foot, Driver, LH, Roland Sands Design®	n/a
3	2	Feeler-Foot Peg, Roland Sands Design®	5142828
4	2	Ring-Retaining, Spiral	7710644
	1	Instructions	9929493

TOOLS REQUIRED

- Safety Glasses
- Pliers, Retaining Ring
- Socket Set, Metric
- Torque Wrench

IMPORTANT

Your accessory kit is exclusively designed for your vehicle. Please read the installation instructions thoroughly before beginning. Installation is easier if the vehicle is clean and free of debris. For your safety, and to ensure a satisfactory installation, perform all installation steps correctly in the sequence shown.

INSTALLATION INSTRUCTIONS

VEHICLE PREPARATION

GENERAL

1. Turn key or ignition switch to OFF position and remove key.
2. Ensure motorcycle is parked on flat surface, kickstand is fully extended, and vehicle is stable prior to installation.

FOOT PEG REMOVAL

1. Remove and discard one retaining ring (A) from pin (B).

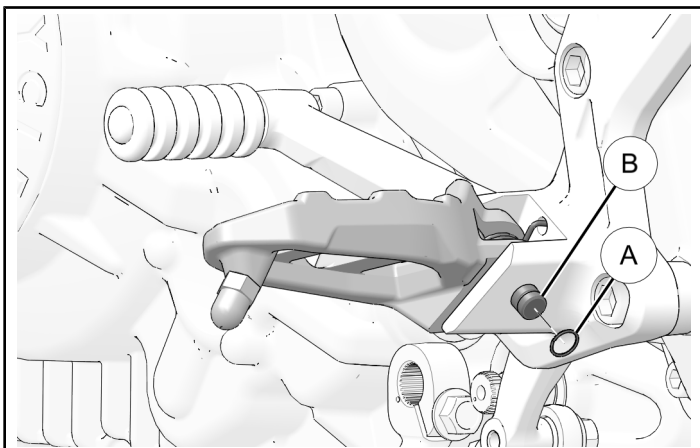

2. Remove and retain one pin (B) and one foot peg spring (C) to remove foot peg.

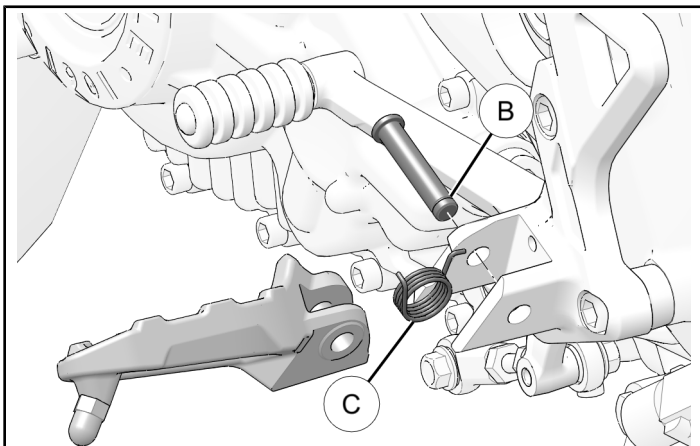

ACCESSORY INSTALLATION

1. Install feeler (3) onto RH foot peg (1).

TORQUE

Feeler (3):
96 in-lbs (11 N·m)

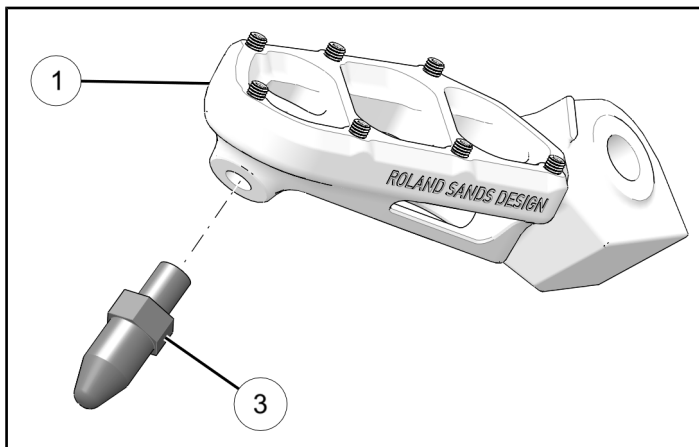

2. Set retained foot peg spring (C) within foot peg cavity (1). Ensure two spring-ends are oriented as shown.

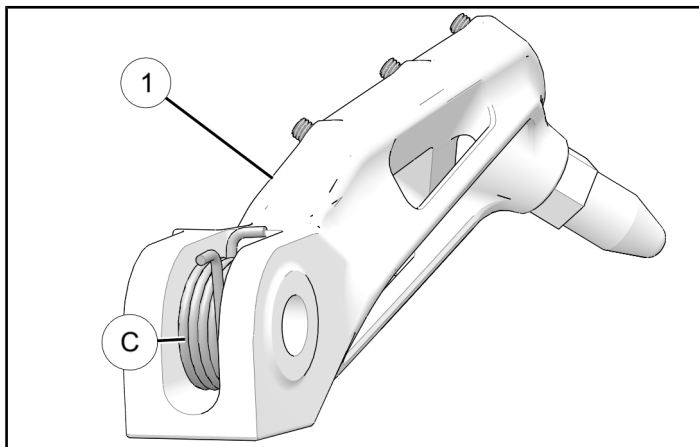

3. Place foot peg ① into foot peg mount and pass retained pin ② through mount and foot peg ①. Ensure spring-end ③ is fitted in foot peg mount cavity.

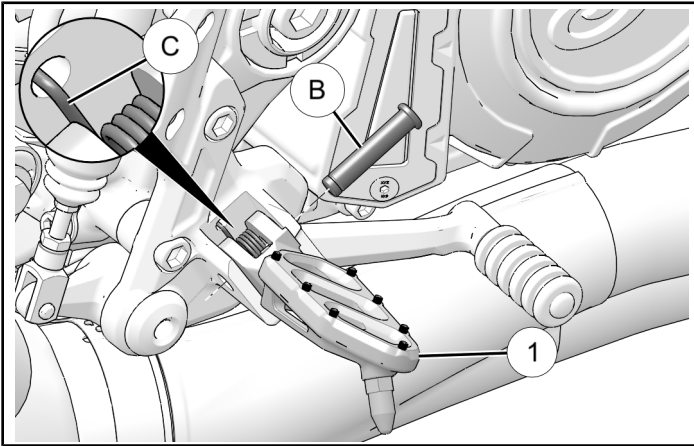

4. Secure pin ② with retaining ring ④.

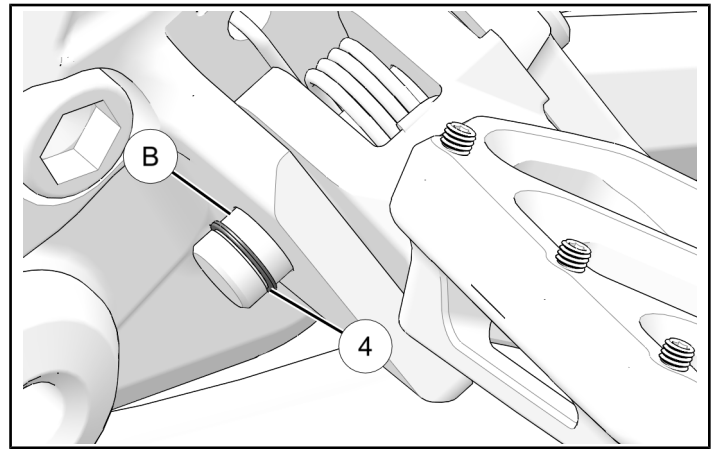

5. Repeat this section for LH foot peg ②.

FEEDBACK FORM

A feedback form has been created for the installer to provide any comments, questions or concerns about the installation instructions. The form is viewable on mobile devices by scanning the QR code or by clicking [HERE](#) if viewing on a PC.

