

SEAT KIT



P/N MULTIPLE

APPLICATION

Verify accessory fitment at www.indianmotorcycle.com.

BEFORE YOU BEGIN

Read these instructions and check to be sure all parts and tools are accounted for. Please retain these installation instructions for future reference and parts ordering information.

KIT CONTENTS

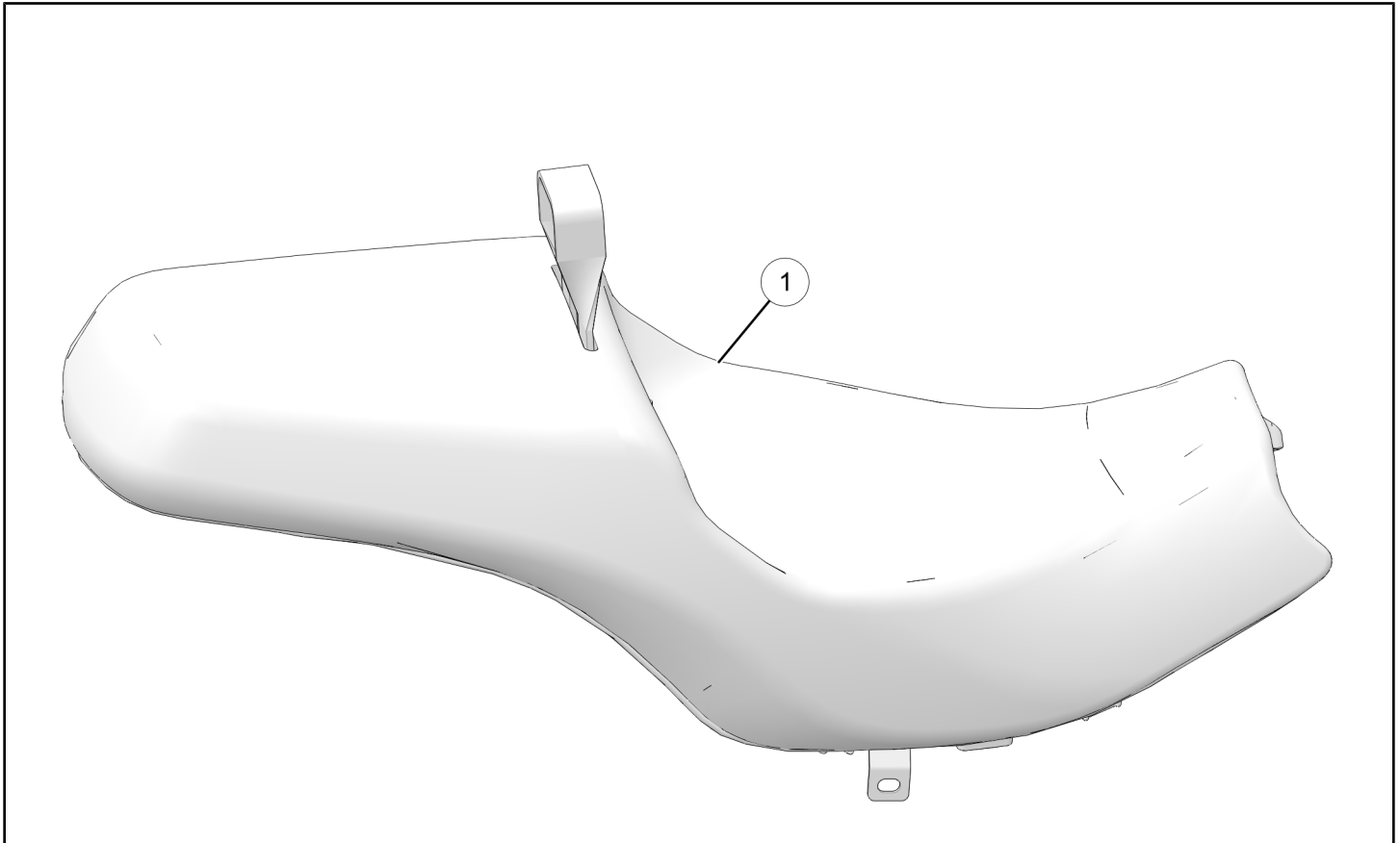

NOTE

XXX = Indian Motorcycle® color code (For example: VBA = Black)

REF	QTY	PART DESCRIPTION
1	1	Assembly, Seat

TOOLS REQUIRED

- Safety Glasses
- Socket Set, Hex Bit, Metric
- Torque Wrench

IMPORTANT

Your Indian Motorcycle® Seat Kit is exclusively designed for your vehicle. Please read the installation instructions thoroughly before beginning. Installation is easier if the vehicle is clean and free of debris. For your safety, and to ensure a satisfactory installation, perform all installation steps correctly in the sequence shown.

INSTALLATION INSTRUCTIONS

VEHICLE PREPARATION

GENERAL

1. Turn key or ignition switch to **OFF** position and remove key. If equipped with keyless fob, remove fob from proximity of vehicle.
2. Ensure motorcycle is parked on a flat surface, kickstand is fully extended, and vehicle is stable prior to installation.

REMOVE RIGHT SIDE PANEL

1. Gently grasp front edge of right side panel and pull away from vehicle to release three grommet pins. Use caution to prevent damage to painted surfaces.

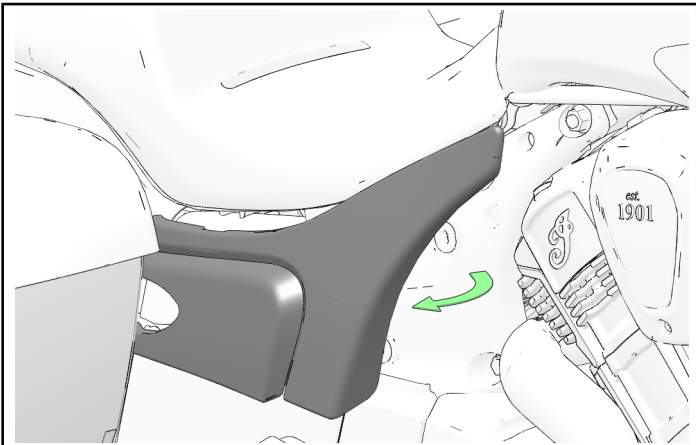

REMOVE LEFT SIDE PANEL

1. Gently grasp front lower corner left side panel and pull away from vehicle to release three grommet pins. Use caution to prevent damage to painted surfaces.

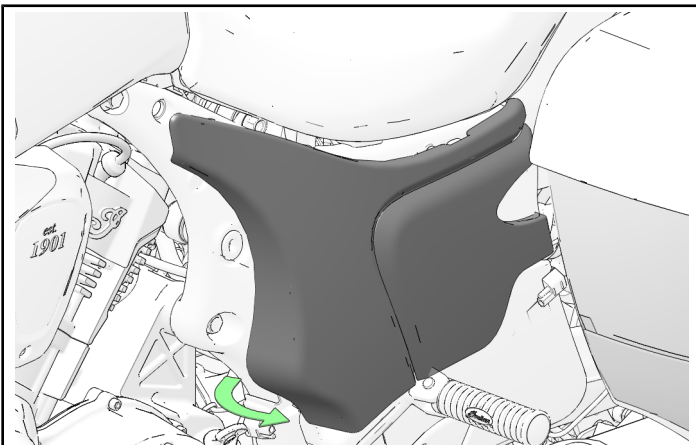

REMOVE SEAT

1. Remove and retain one screw from each side of seat.

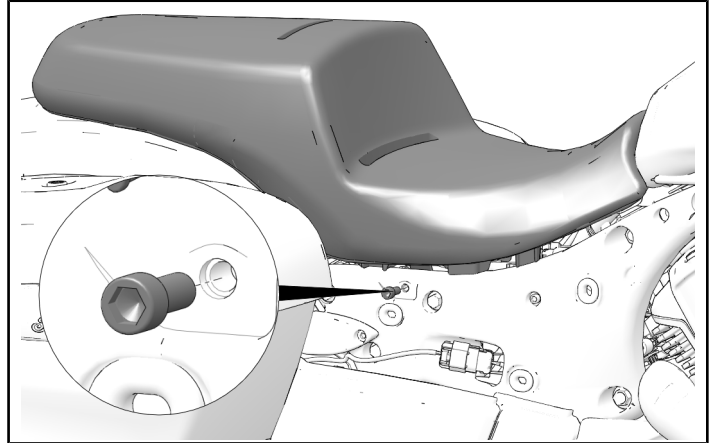

2. Pull seat rearward, then upward to disengage seat from frame mount and hat bushing. Do not allow seat mount brackets to contact rear fender.

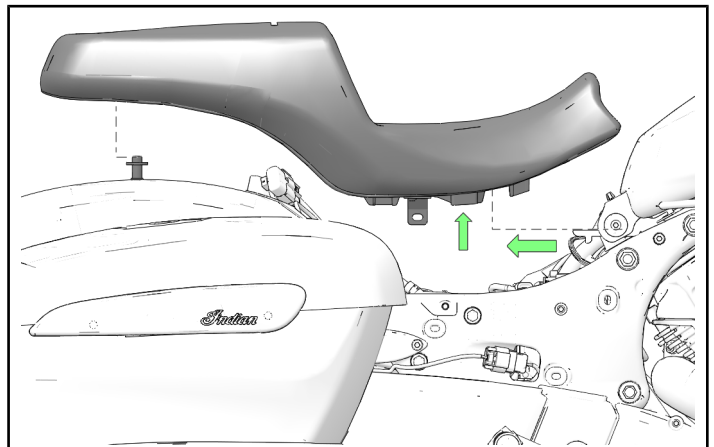

ACCESSORY INSTALLATION

1. Install new seat ① on motorcycle, insert hat bushing A into slot under rear of seat and slide seat forward, ensuring that tabs B engage slots on new seat. Do not allow seat mount brackets to contact rear fender.

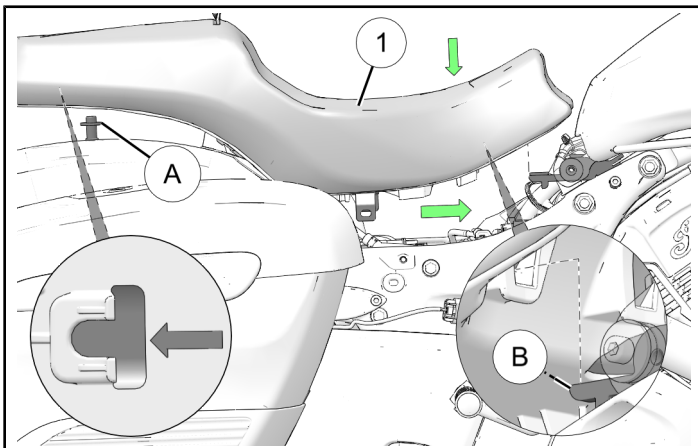

2. Pull straight up on front of seat to ensure a secure fitting.
3. Move seat ① until tabs align with hole in frame as shown and reinstall retained screws. Torque screws to specification.

TORQUE

Seat Mount Bracket Screws:
18 ft-lbs (24 N·m)

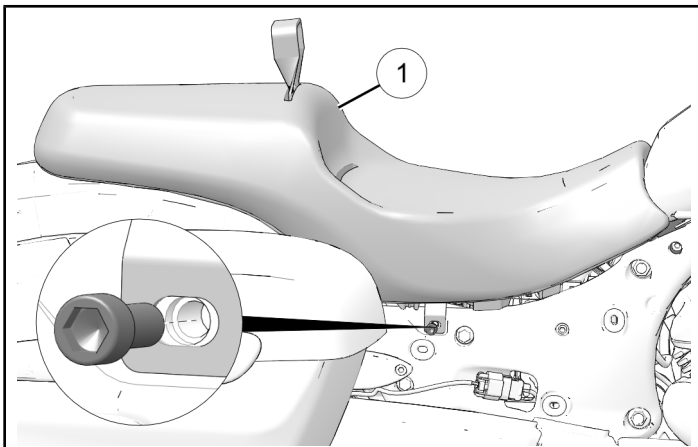

⚠ WARNING

Seat must be properly installed for safe operation of motorcycle. Failure to ensure proper installation may lead to loss of control and result in serious injury or death.

VEHICLE REASSEMBLY

GENERAL

1. Reinstall left and right side covers. Ensure all three anchors on each cover are fully engaged.

NOTE

See owner's manual for seat care instructions.

FEEDBACK FORM

A feedback form has been created for the installer to provide any comments, questions or concerns about the installation instructions. The form is viewable on mobile devices by scanning the QR code or by clicking [HERE](#) if viewing on a PC.

