

STAGE 3 116 KIT MODEL YEAR 2019+



P/N 2883921

IMPORTANT

Due to the technical nature of this kit, Indian® insists that this installation be performed by a certified Indian Motorcycle® Technician.

NOTICE

Factory approved and certified accessories and calibrations are designed for maximum performance, while protecting the engine over a wide range of operating conditions. Use of aftermarket or unapproved accessories or calibrations will cause abnormal sensor or engine operation, error codes and risks damage to the engine. The Indian Motorcycle® Limited Warranty *excludes* damages or failures resulting from use of aftermarket or unapproved components, accessories, and calibrations.

APPLICATION

Model 2019 and newer Indian® Motorcycles with 111 Thunder Stroke®
Verify accessory fitment at www.indianmotorcycle.com.

BEFORE YOU BEGIN

Read these instructions and check to be sure all parts and tools are accounted for. Please retain these installation instructions for future reference and parts ordering information.

REQUIRED SOLD SEPARATELY

The Indian Stage 3 116 Kit Model Year 2019+ contains parts for installation of the Stage 3 116 Kit only. Prior installation of the following additional kits is also required (sold separately):

- Stage 1 High Performance Air Cleaner Kit, PN 2881779-XXX or Thunder Stroke® High Flow Air Cleaner Kit, PN 2880654-XXX
- Stage 1 Muffler Kit, PN 2879529-XXX, 2879724-XXX, 2879768-XXX, or 2879769-XXX

NOTE

XXX = Indian® color code (For example: 266 = Black)

KIT CONTENTS

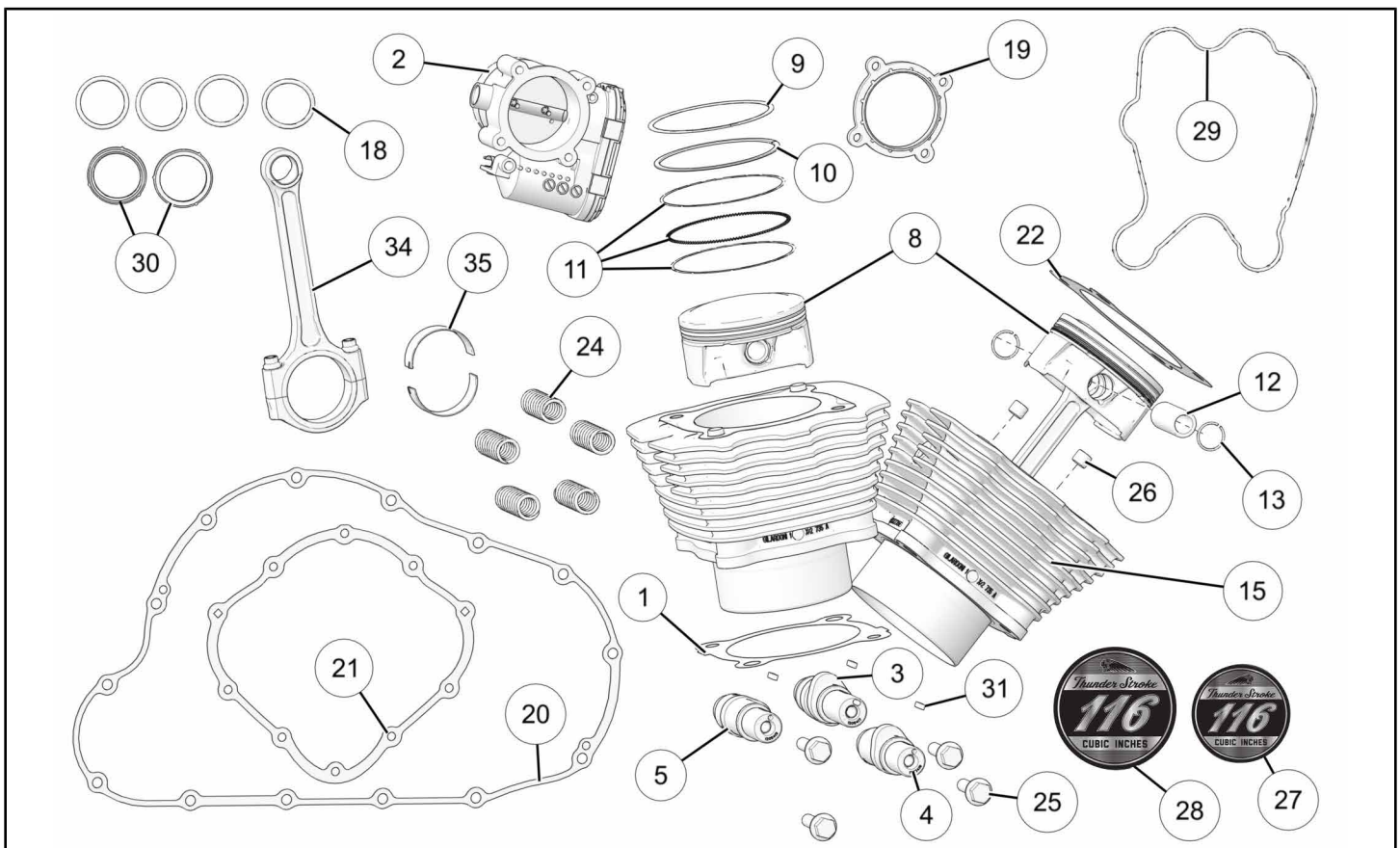

REF	QTY	PART DESCRIPTION	PART NUMBER
1	2	Gasket, Base	5256328
2	1	Assembly, Throttle Body	1204975
3	1	Assembly, Camshaft, Stage 3, Intake	1205417
4	1	Assembly, Camshaft, Stage 3, Exhaust-Front	1205418
5	1	Assembly, Camshaft, Stage 3, Exhaust-Rear	1205419
8	2	Assembly, Piston, 103.2 MM	3023066
9	2	.Ring, Top, Piston, 103.2 MM	3023069
10	2	.Ring, Second, Piston, 103.2 MM	3023070
11	2	.Ring, Oil, Piston, 103.2 MM	3023068
12	2	.Pin, Piston, 22 MM	3023324
13	4	.Ring, Retaining, Round, 22 X 1.6 MM	7710479
15	2	Cylinder, 103.2 MM	5140989
18	8	O-Ring, 36.091 X 3.53	5416074
19	1	Gasket, Airbox	-
20	1	Gasket, Primary Cover	5813897
21	1	Gasket, Camshaft Outer Cover	5813898
22	2	Gasket, Cylinder Head, 103.2 MM	5814541

REF	QTY	PART DESCRIPTION	PART NUMBER
24	5	Clutch Spring, 395N	7044826
25	4	Screw, Hex Flange Head, M10 X 1.5 X 40	7519763
26	4	Dowel, Hollow, M13 X 10	7663008
27	1	Badge, Outer Cam Cover	5266138-01
28	1	Badge, Outer Primary Cover	5266139-01
29	2	Seal, Valve Cover	5414859
30	2	Gasket, Exhaust	5257156
31	3	Key, Round, End, 4 X 4 X 16	7710623
33	1	Calibration Card, 50 State, Indian (Not Shown)	-
34	2	Assembly, Connecting Rod, Billet, 184 MM	3023589
35	4	Bearing, Rod, 52 MM	3515097-002
36	1	Fastener Assembly Lube, 1.0 oz. (Not Shown)	-
	1	Instructions	9929249

TOOLS REQUIRED

- Safety Glasses
- Breaker Bar
- Digital Wrench
- Drain Pan
- Hammer, Soft Face
- Piston Ring Compressor, Two-Piece Plier Style
- Platform Jack, Motorcycle
- Pliers, Side Cutting
- Pry Tool
- Screwdriver, Phillips
- Screwdriver, Slotted
- Socket Set, Hex Bit, Metric
- Socket Set, Metric
- Socket Set, Torx® Bit
- Torque Wrench
- Wrench Set, Metric
- Wrench, 0° Offset 12-point Box End, 10 mm
- Valve Spring Compressor
- Vehicle Lift/Support Equipment
- **Special Service Tool:**
3/8" Drive 12-Point Metric 10 mm Torque Adaptor
PN FRDHM10

CONSUMABLES REQUIRED

- Gloves, Chemical Resistant
- Grease, White Lithium
- Room Temperature Vulcanization Silicone (RTV), Loctite® SI 698 Black (or equivalent)
- Solvent Wipe (99% Isopropyl Alcohol)

IMPORTANT

Your Indian Stage 3 116 Kit Model Year 2019+ is exclusively designed for your vehicle. Please read the installation instructions thoroughly before beginning. Installation is easier if the vehicle is clean and free of debris. For your safety, and to ensure a satisfactory installation, perform all installation steps correctly in the sequence shown.

MAINTENANCE

Installation of the 116ci Big Bore Kit replaces several major engine components. Indian Motorcycle® recommends changing the engine oil and filter after the first **500 miles (805 km)** following installation and each subsequent 5,000 mil (8046 km) interval as outlines in the standard Maintenance Schedule. (Example: Odometer reading at 116ci kit install: 0 miles; 1st oil change at 500 miles; 2nd oil change at 5,000 miles; 3rd oil change at 10,000 miles; 4th oil change at 15,000 miles; etc.)

ASSEMBLY TIME

Approximately 12 hours

INSTALLATION INSTRUCTIONS

IMPORTANT

Protect all finished surfaces during these operations.

NOTE

Take careful notes of wire routing and cable tie locations during disassembly to ensure proper reinstallation.

Special care should be taken on higher mileage bikes during disassembly. Especially when removing fasteners threaded into engine block and cylinder heads (For example: Exhaust manifold bolts, Primary cover bolts, etc.) Thread repair kit may be necessary if threads become damaged.

VEHICLE PREPARATION

1. Turn key or ignition switch to "OFF" position and remove key. If equipped with keyless fob, remove fob from proximity of vehicle.
2. Ensure motorcycle is parked on a flat surface, kickstand is fully extended, and vehicle is stable prior to installation.
3. Remove front fender as per service manual.
4. Support motorcycle securely in an upright position. Clamp front tire securely in a wheel vise.

ENGINE REMOVAL PREPARATION

1. Drain engine oil.
2. Remove and retain upper and lower side covers, saddlebags, seat, battery, and fuel tank as per service manual.
3. Disconnect Oxygen sensor wiring connectors and remove exhaust system as per service manual.

4. Remove and retain four screws **(A)** and **(B)** and remove drive sprocket cover **(C)**.

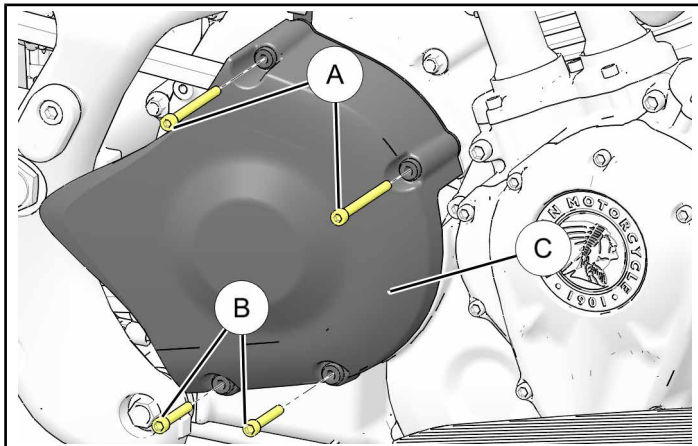

5. Remove and retain three screws **(D)** and cover **(E)**.

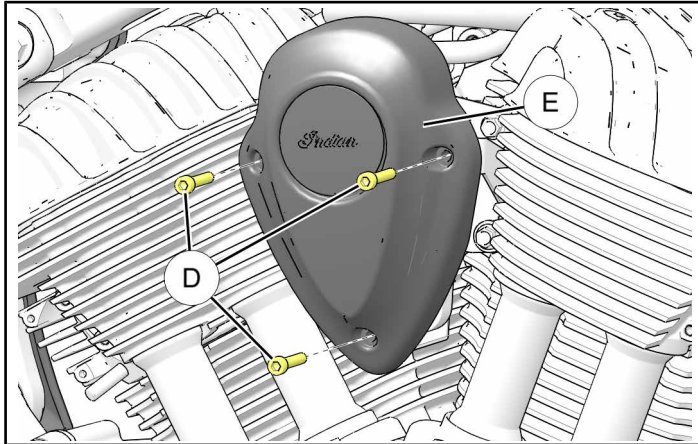

6. Mark ignition cables and remove from ignition coil (K). Unplug connector (L). Remove and retain ground wire screw (M). Remove and retain three screws (G) and remove ignition coil (K) from engine.

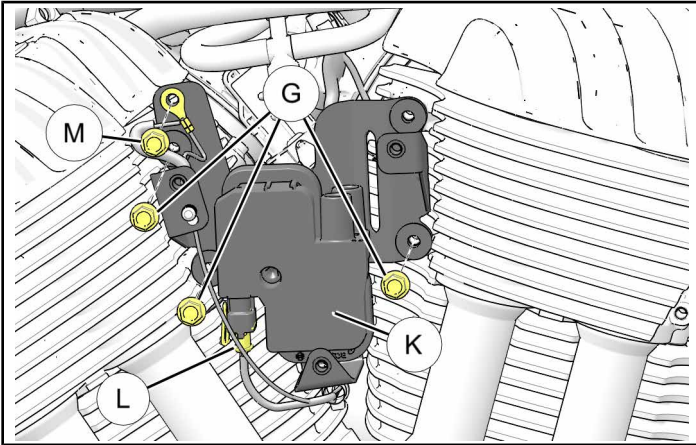

7. Remove floorboards as per service manual.
8. Remove highway bars (if installed) as per service manual.
9. Loosen (**DO NOT REMOVE**) rear axle nut (N). Loosen belt tension adjustment nuts (P) to relieve tension and remove belt from sprocket.

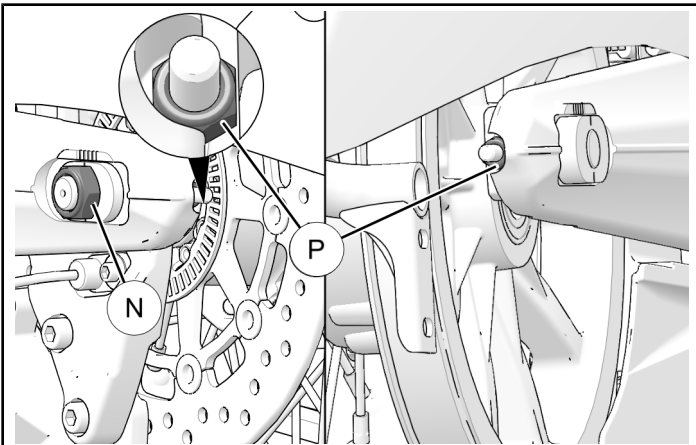

10. Remove airbox and throttle valve as per service manual.

11. Unplug TMAP Sensor (Q) and CHT Sensor (R). Remove and retain screw (S) and knock sensor (T).

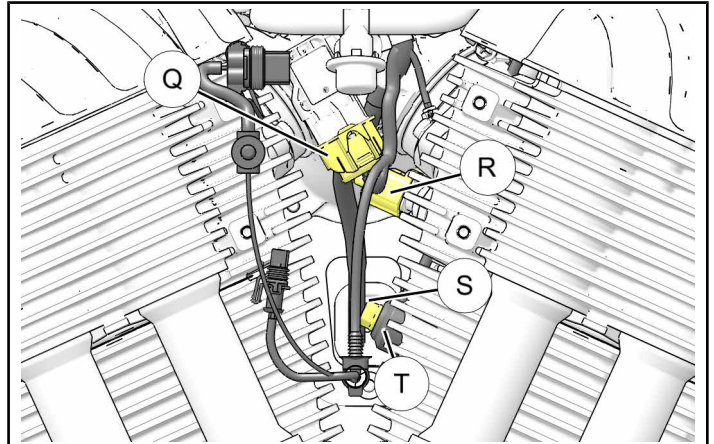

12. Remove top oil cooler fastener (U) and release oil cooler (V) from lower mounting. (Skip this step if oil cooler not equipped.)

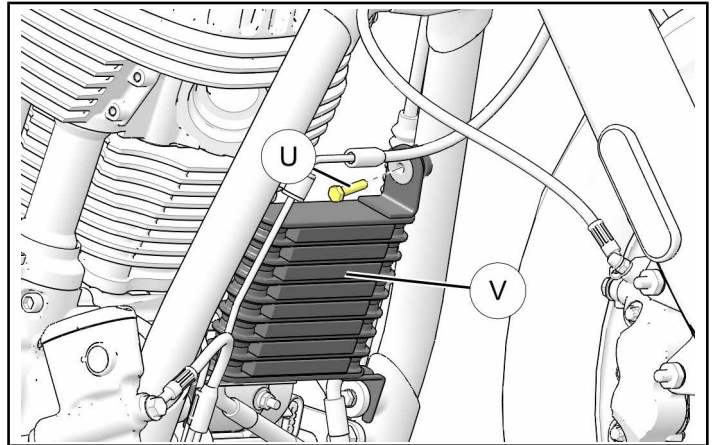

CALIFORNIA AND INTERNATIONAL MODELS ONLY

North American models: Skip to Next Section

1. Disconnect two hoses (A) from canister (B).

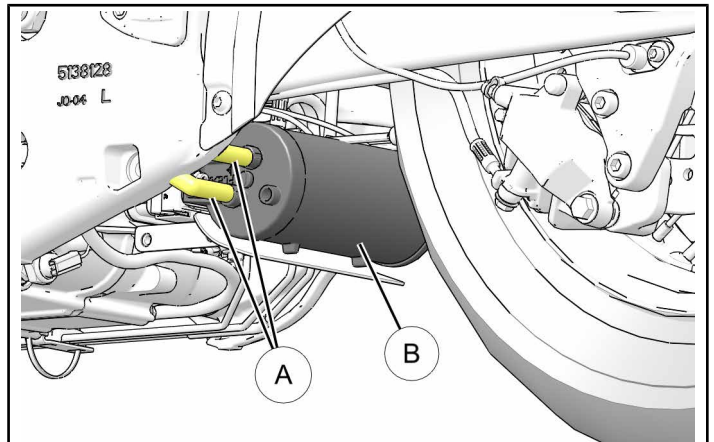

- Remove and retain two fasteners (C) and remove charcoal canister (B) from bracket.

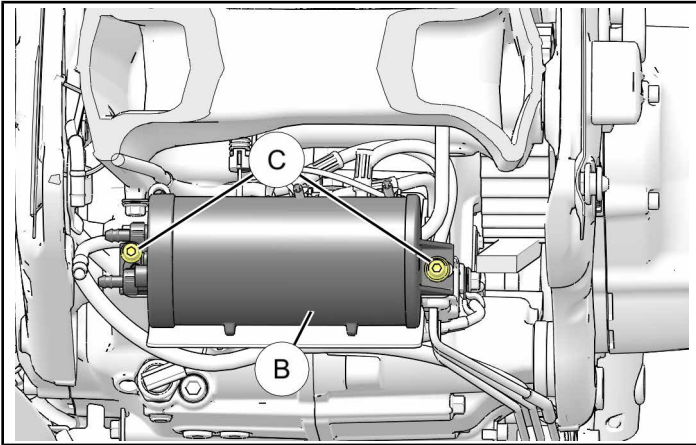

- Remove and retain two fasteners (D). Disconnect main ABS electrical connector and two brake switch connectors from ABS module.

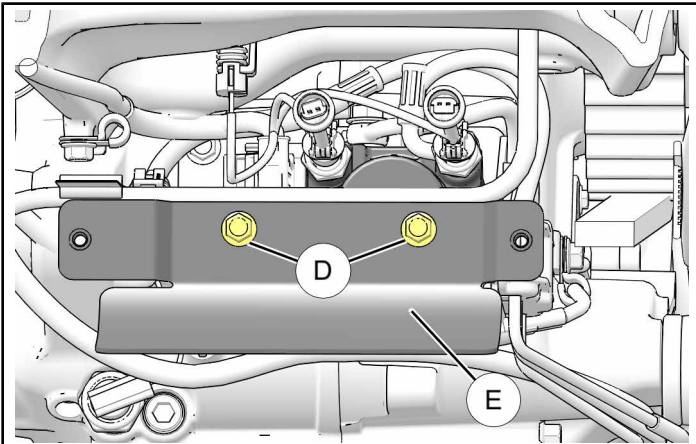

NOTE

It is not necessary to remove hydraulic lines from ABS module during engine removal.

- Remove and retain four fasteners (F) from ABS bracket (G).

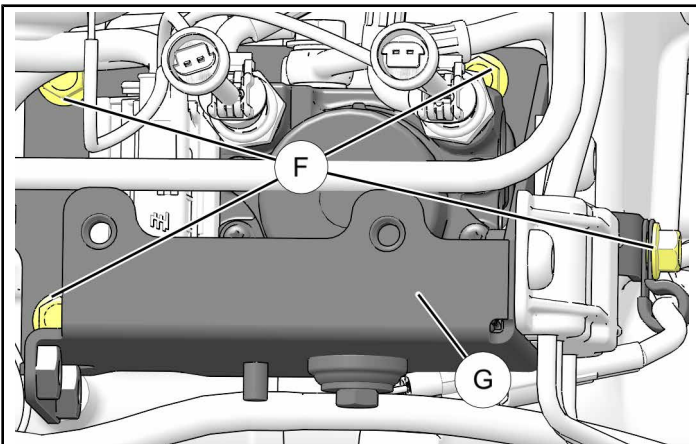

- Move ABS module/bracket and hydraulic brake lines far enough away from RH side of engine so engine can be lowered.

ENGINE REMOVAL

- Remove and retain side stand bumper bolt (A) and clutch cable E-clip (B).

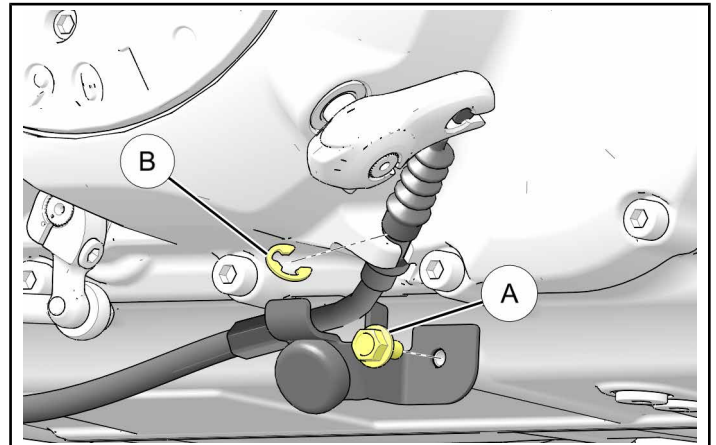

- Protect clutch release arm (C) with a shop towel. Rotate release arm inward. Disconnect clutch cable (D) from release arm.

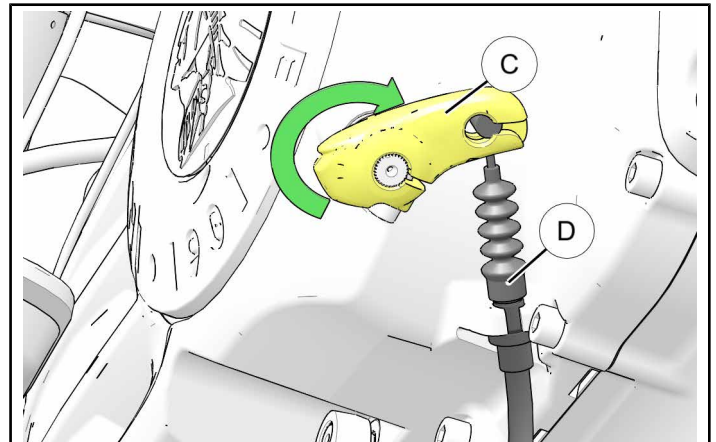

- Withdraw clutch cable (D) from mounting boss located on primary cover.

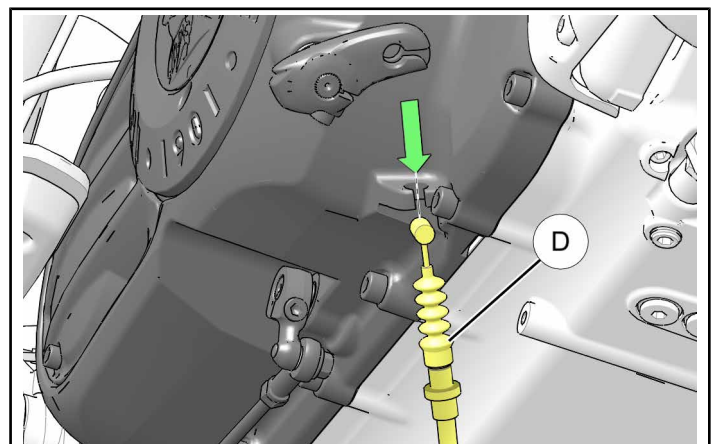

4. Disconnect electrical connect for kickstand switch **E**. Remove and retain two screws **F** and kickstand switch **E**.

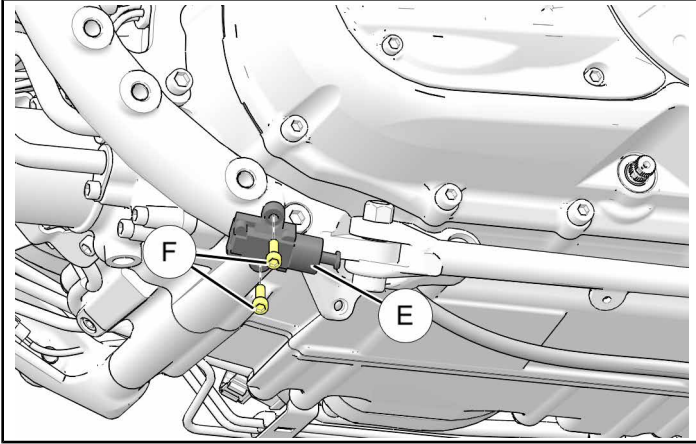

5. Flip kick stand down. Place small platform jack beneath engine just before front frame **G** (shown with arrow) and raise enough to support crankcase. Ensure clutch cable **D** is not pinched between jack and frame.

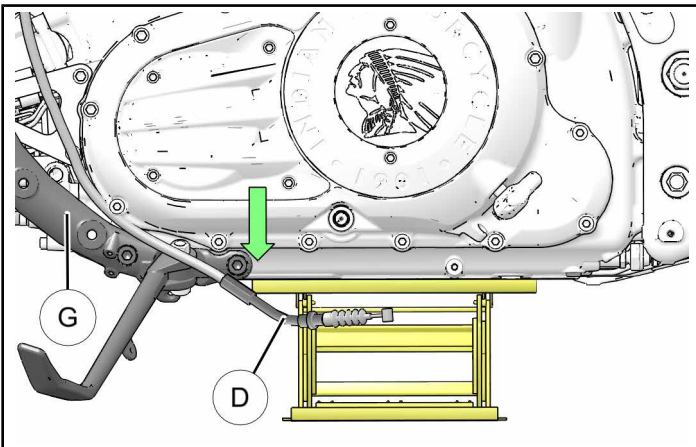

6. Remove and retain two screws **H**, one bolt **J** and nut **K**, screws **L**, **M**, and **N**, and remove LH frame downtube **G**.

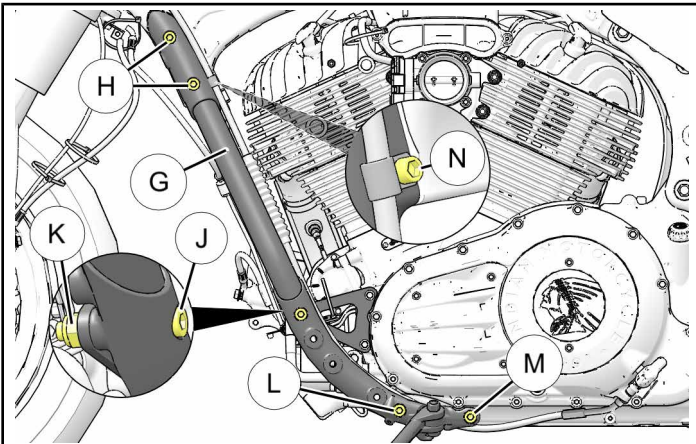

7. Remove and retain two screws **P** and remove RH frame downtube **Q**.

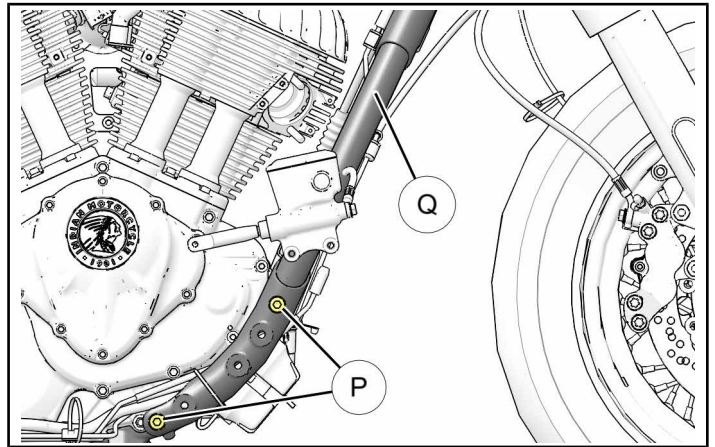

8. Position clutch cable so it is clear of engine area.
9. Remove and retain two fasteners **R** securing battery tray to engine and one screw **S** securing ground cable to engine case.

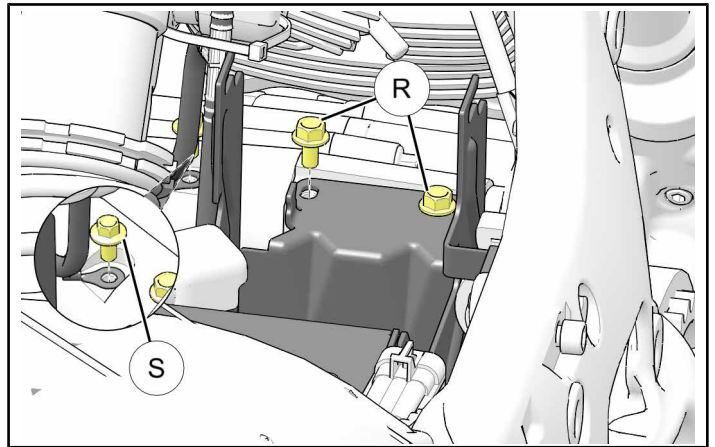

10. Slide the platform jack forward so its leading edge is under end of flat portion of engine as shown. Raise jack to support engine.

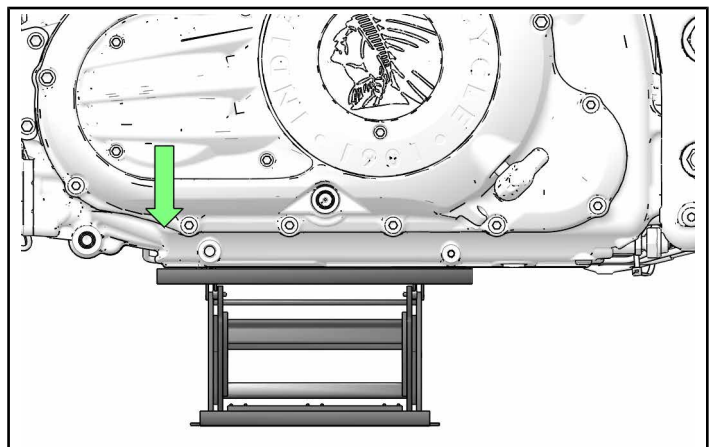

11. On RH side of engine, remove and retain upper **T** and lower **U** engine mount bolts. Remove and retain two spacers **V** from between engine and frame panel.

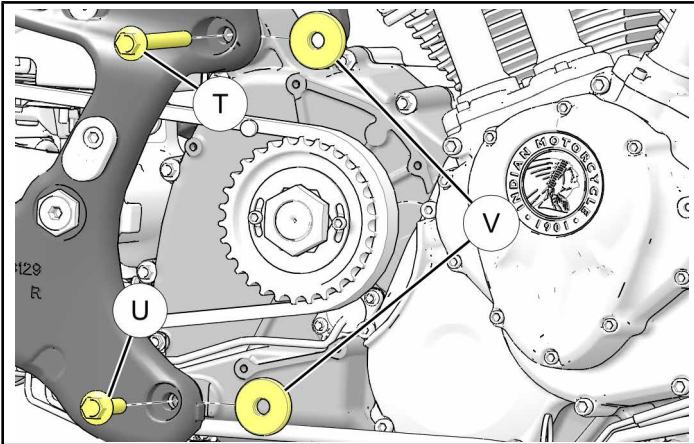

12. On LH side of engine, remove and retain two engine mount bolts **W**.

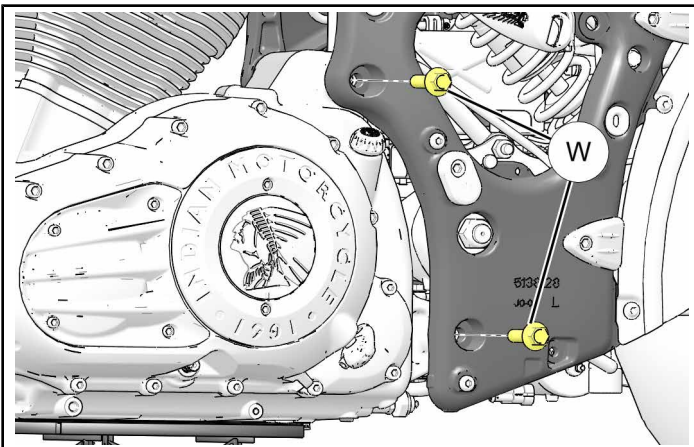

13. Push engine slightly to RH side to release from alignment dowels. With an assistant, carefully lower engine from frame.

14. Disconnect any remaining electrical, vacuum, or breather lines from top of engine.

NOTE

Take careful notes of wire routing and cable tie locations during disassembly to ensure proper reinstallation.

REMOVE CYLINDER HEADS AND CYLINDERS.

1. Remove and retain six upper valve cover screws **A**. Remove both valve covers **B** and set aside.

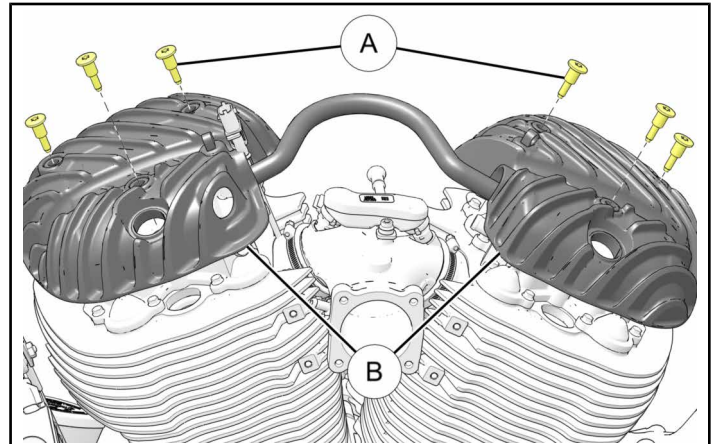

2. Fuel rail assembly **C** and injectors **D** will NOT be removed. Remove and retain two hose clamps **E** and intake manifold **F** with fuel rail and injectors still installed.

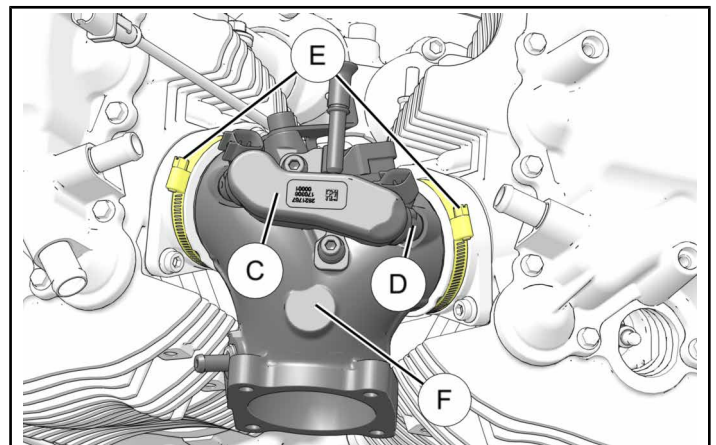

3. Remove and retain eighteen screws **G** and front **H** and rear **J** lower valve covers.

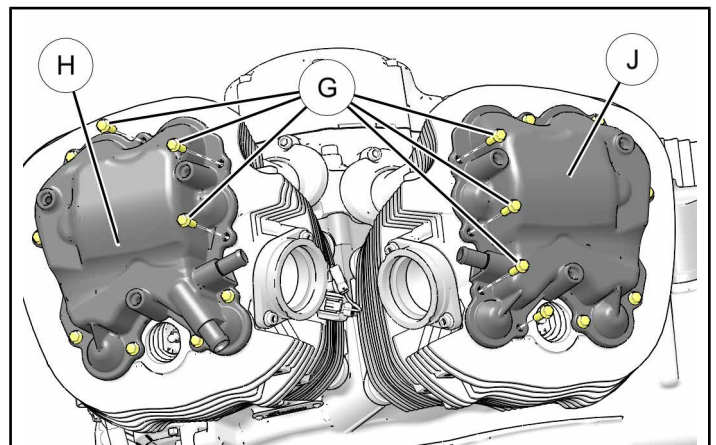

- Loosen rocker arm bolts (K) and turn rocker arms (L) enough to remove pushrods (M). Label pushrods upon removal for reinstallation.

CAUTION

If engine will be disassembled for extended period of time (overnight), the hydraulic lifters may bleed down. To prevent this, place hydraulic lifters in oil bath until ready for reassembly. Failure to do this may cause engine to NOT turn over with starter motor upon initial reassembly of engine.

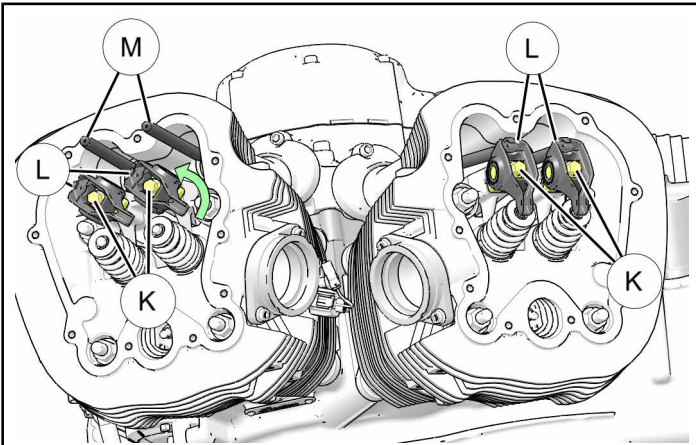

- Alternately loosen eight cylinder head nuts (N). Remove and retain eight nuts (N) and eight washers (P).

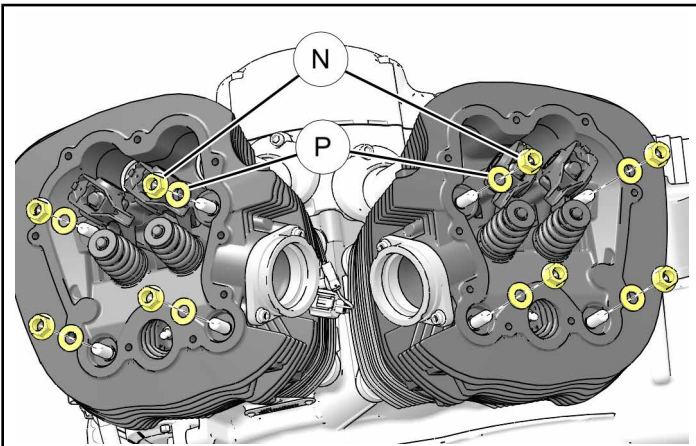

- Remove cylinder heads (Q), head gaskets (R), and four pushrod tubes (S). Label and set parts aside.

NOTE

Separation of cylinder heads from push rod tubes may be difficult, particularly on high mileage engines. Special care or modified process may be required.

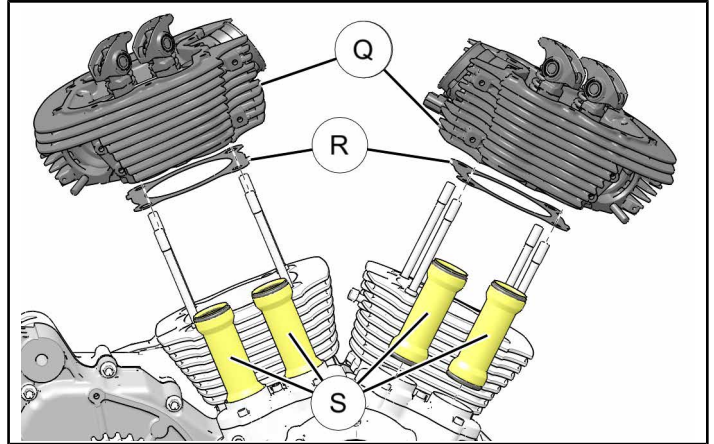

- Clean head gasket mounting surface on bottom of cylinder head.
- Lift and remove both cylinders (T) and gaskets (U) from engine block.

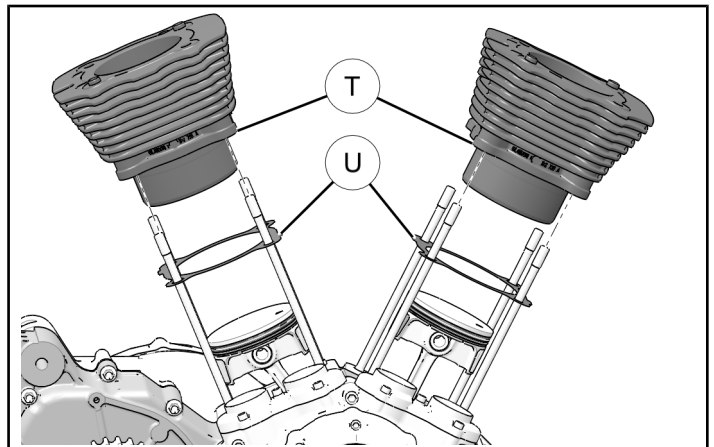

- Clean cylinder gasket mounting surface on top of engine block.
- Slide rubber hoses over lower studs to protect piston rings from damage.

PISTON AND CONNECTING ROD REPLACEMENT

PISTON REMOVAL

1. Remove left piston pin retaining ring. (A). Push piston pin (B) out to left side of engine and remove stock piston (C).

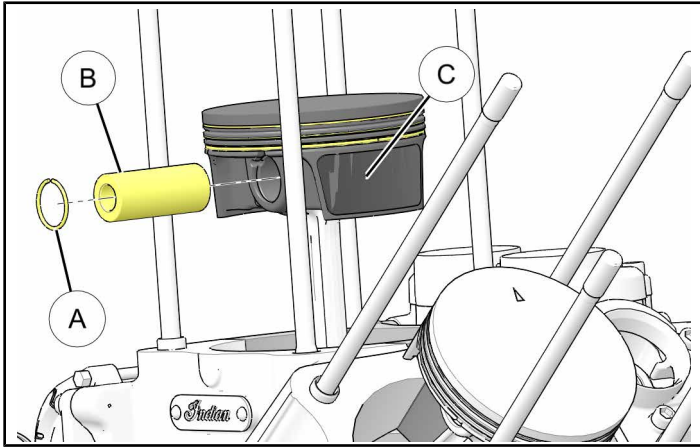

2. Repeat step for other piston.

CONNECTING ROD REMOVAL

NOTICE

This procedure requires the use of a 10mm Torque Adapter (PN: **FRDHM10**). Failure to use this tool for the procedure may cause damage to connecting rod bolts.



CAUTION

The piston cooling jet (A) is located on the inside of cylinder wall. Be careful not to damage cooling jet during connecting rod replacement.

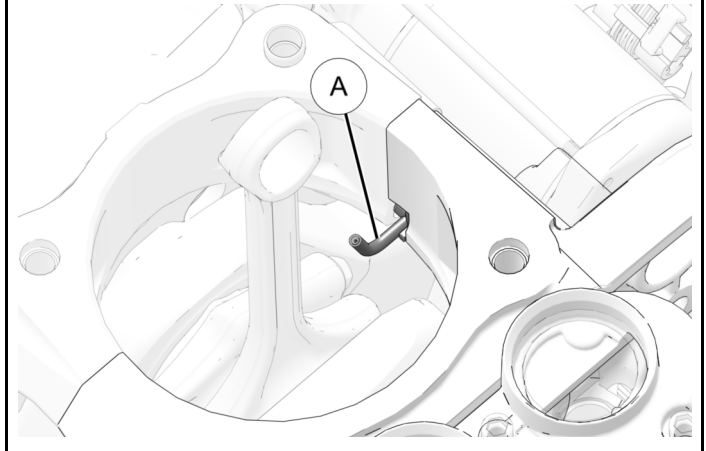

1. Assemble Special Tool (PN **FRDHM10**) to an 8 inch (203 mm) extension and ratchet as shown.



IMPORTANT

Do NOT use a wobble type extension.

IMPORTANT

Ensure detent ball engages in the hole of the tool.

STOP!

Serious damage may occur if the following step is not performed properly.

IMPORTANT

Make sure to turn the connecting rod bolt in the correct orientation. Turn the socket clockwise when looking down at the rod through the cylinder bore.

2. Using following detailed steps, remove connecting rod fasteners and **DISCARD** both parts of the connecting rod and fasteners.

TIP

Have a second technician hold engine in place while loosening connecting rod screws.

Working from pushrod side of engine:

- a. Position Crank Pin **(B)** @ 10 o'clock. Hold connecting rod in cylinder bore as shown. Remove rear connecting rod, rear bolt **(C)** using special tool **FRDHM10** and discard.

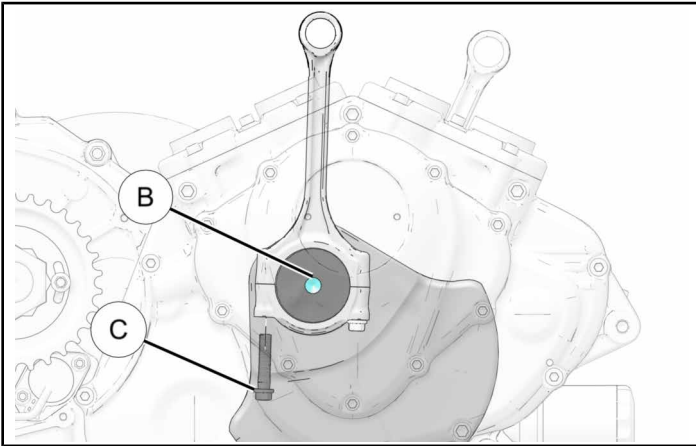

- b. Position Crank Pin **(B)** @ 12 o'clock. Allow connecting rods to rest in cylinder bore as shown. Remove rear connecting rod, front bolt **(D)** and front connecting rod rear bolt **(E)** using 0° offset 12-pt 10mm box end wrench

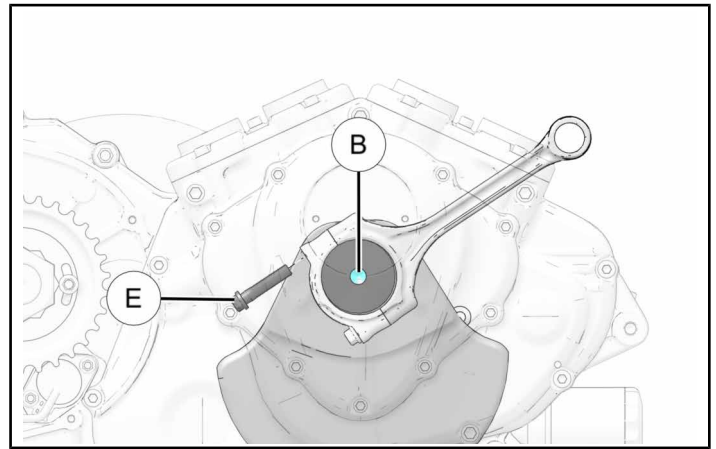
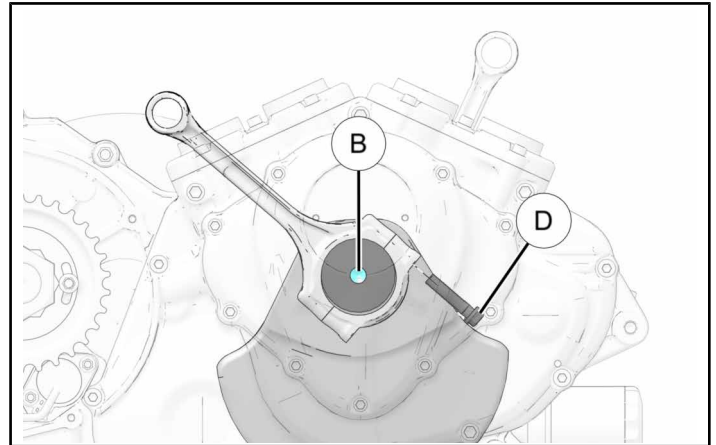

- c. Position Crank Pin **(B)** @ 2 o'clock. Hold connecting rod in cylinder bore as shown. Remove front connecting rod, front bolt **(F)** using special tool **FRDHM10** and discard.

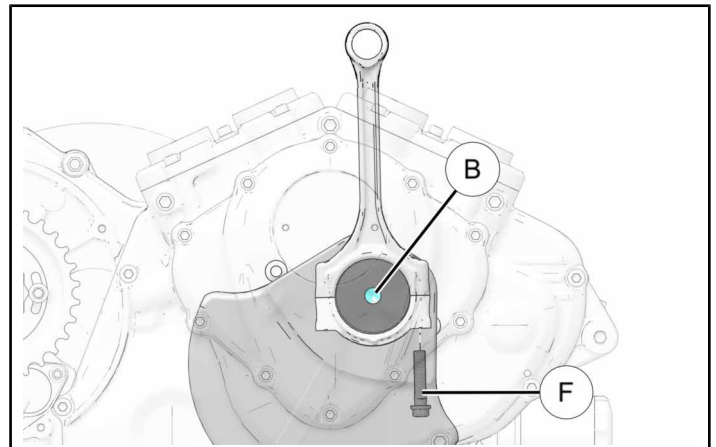

- d. Carefully remove both connecting rods, ensure connecting rod bearing are also removed and discard.

CAUTION

Magnets used to recover items from crankcase must be clean and free from debris.

CAUTION

Do NOT rock connecting rod back and forth to remove bearing cap, crankshaft bearing damage may occur.

CONNECTING ROD INSTALLATION

CAUTION

Inspect cylinder for debris and clean prior to installation, if necessary.

1. Carefully remove and retain bolts (A) from connecting rod assemblies (3 & 4). Carefully separate connecting rods and caps.

IMPORTANT

Connecting rods and connecting rod caps are matched sets. Ensure to keep pairs together.

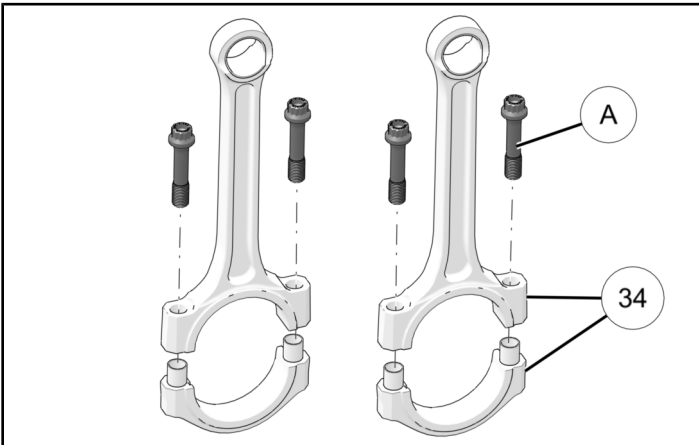

2. Install Rod Bearing Halves (35) into each connecting rod. Ensure tabs on bearings line up with slots on connecting rods and are centered.

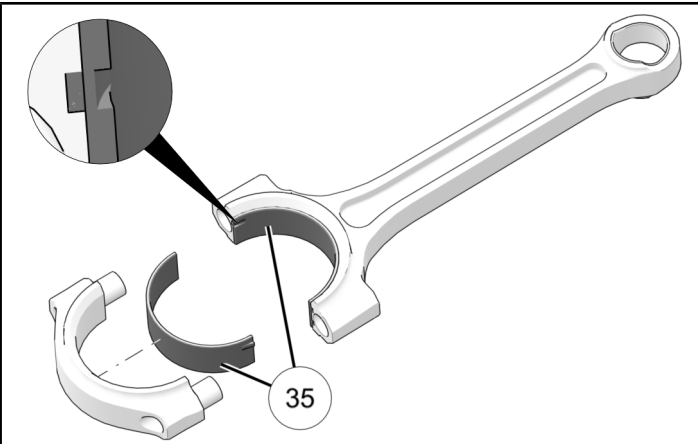

3. Install the bottom half of the connecting rod onto the crankshaft.

IMPORTANT

The connecting rods are machine split. Ensure the bearing is properly installed and mark the both halves of the connecting rod prior to installation.

4. Apply Moly lube to bearing surfaces.
5. Apply assembly lube (PN 8560265) to connecting rod fasteners. Ensure assembly lube is applied to threads of connecting rod bolts AND under bolt heads.

- Install top half over bottom half. Hand tighten connecting rod fasteners. Torque connecting rod fasteners to specification.

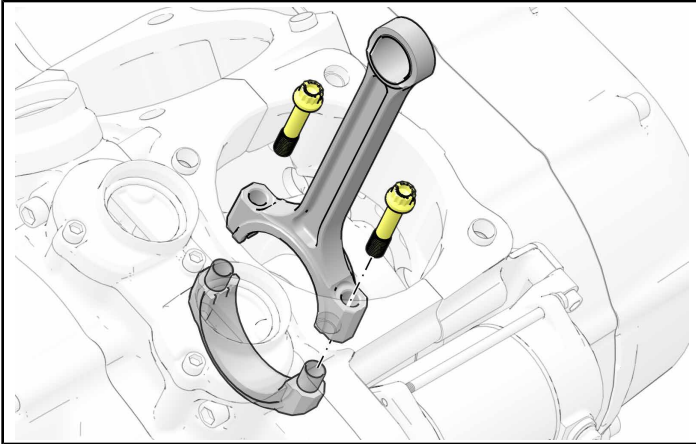

IMPORTANT

Ensure chamfered side **(B)** of connecting rods are orientated as shown.

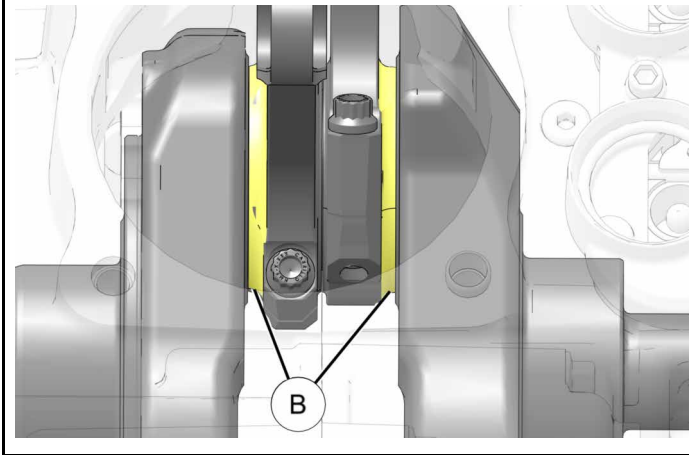

CAUTION

Magnets used to recover items from crankcase must be clean and free from debris.

TORQUE

Connecting Rod Fasteners: **46 ft. lbs. (62 Nm)**

IMPORTANT

Verify that piston cooling jet was not damaged during connecting rod removal or installation.

PISTON RING ALIGNMENT

- Ensure piston ring gaps are aligned as shown:
 Compression Ring 1 and 2 **(1)**
 Upper Oil Control Ring **(2)**
 Lower Oil Control Ring **(3)**
 Expander Ring **(4)**

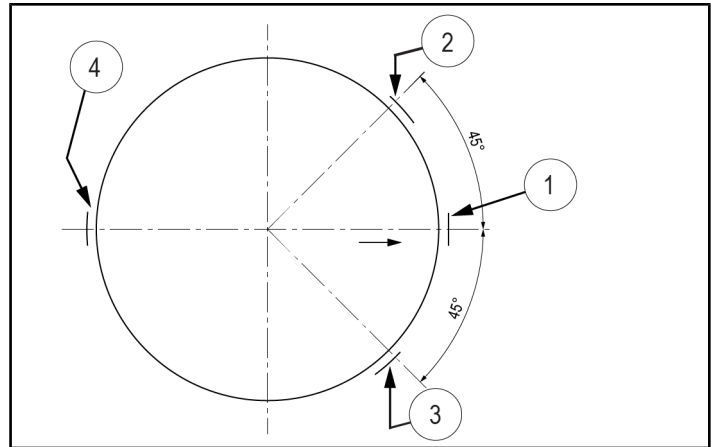

- Lubricate all rings and sides of pistons with engine oil.

PISTON AND CYLINDER INSTALLATION

NOTE

Pistons are marked with an arrow on crown. Install with arrow facing **FRONT** of engine.

- Apply a light coat of engine oil to piston and rings.
- Place a clean shop towel over crankcase to prevent foreign material from entering crankcase.
- Ensure retaining ring **(13)** is installed on one side of piston **(8)** with end gap facing **UP** (12:00 position).

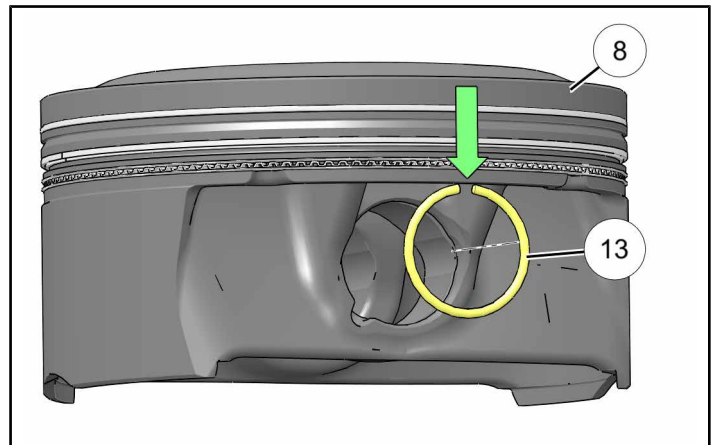

- Slide piston pin **(12)** out of piston **(8)**.
- Install piston **(8)** over connecting rod with arrow on piston crown facing **FRONT** of engine.

6. Slide piston pin ⑫ back into piston ⑧.
7. Install new retaining ring ⑬ on piston ⑧ with end gap facing **UP** (12:00 position).

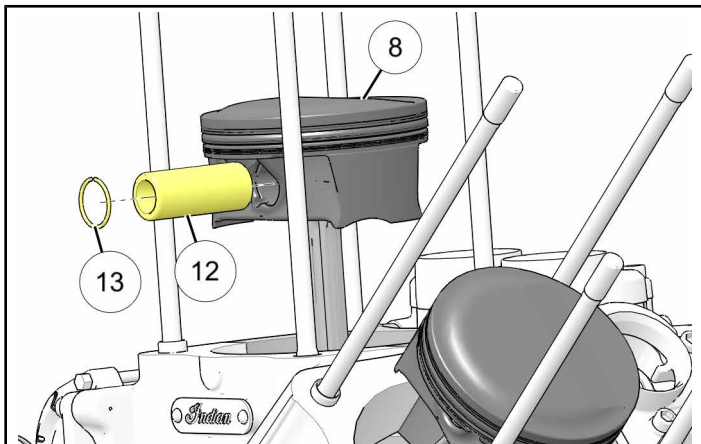

8. Repeat steps 1-6 for second piston.
9. Transfer any sensors or brackets over from the stock cylinders to the new cylinders.

TORQUE

Knock Sensor Fastener: 15 ft. lbs. (20 Nm)

10. Apply RTV Silicone (Loctite® SI 698 Black or similar) to split line of engine block on both sides of cylinder (shown with arrows).

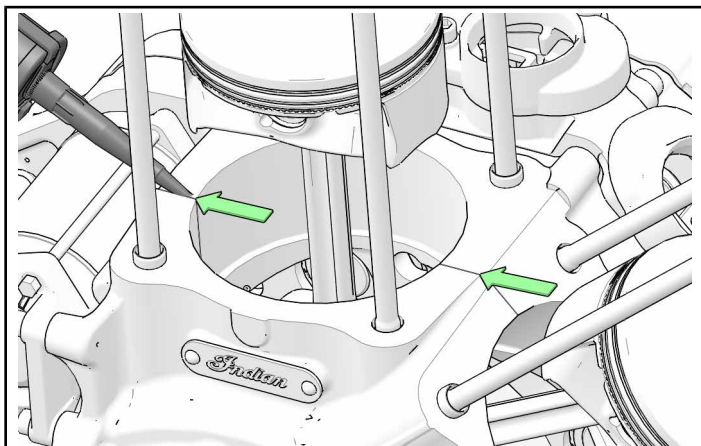

11. Install new base gasket ① on engine block.

12. Double check piston ring gap placement and install piston ring compressor around piston ⑧. Remove protective hoses from cylinder studs.

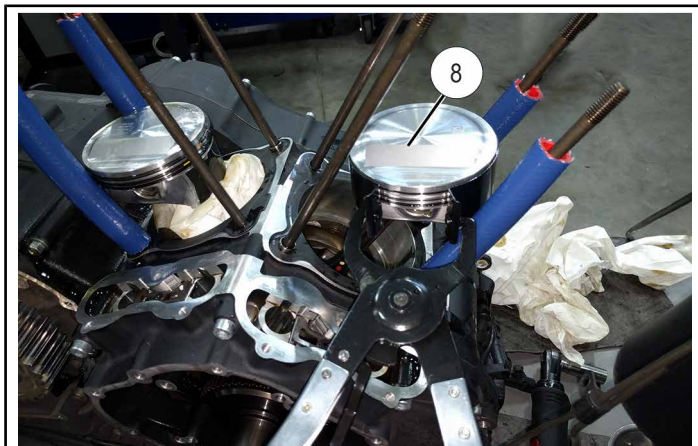

13. Hold piston in place and carefully slide cylinder ⑮ over piston ring assembly. **Do not force cylinder over piston.** Monitor rings carefully. If a piston ring become dislodged from ring compressor, remove cylinder and inspect ring carefully for damage.

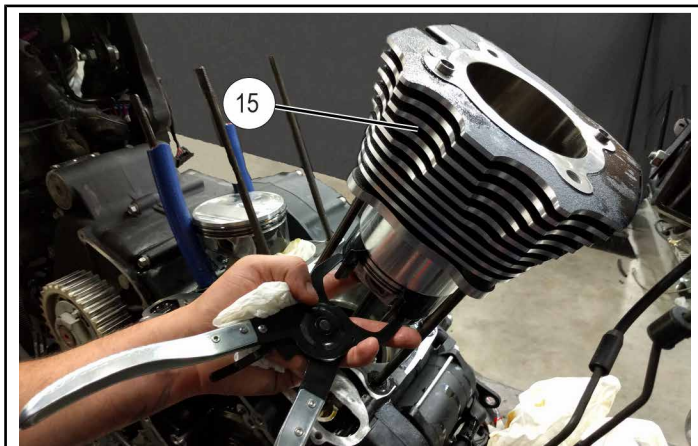

14. Remove piston ring compressor once rings are fully captive in cylinder.
15. Slide cylinder ⑮ down over piston until seated to base gasket and crankcase surface.

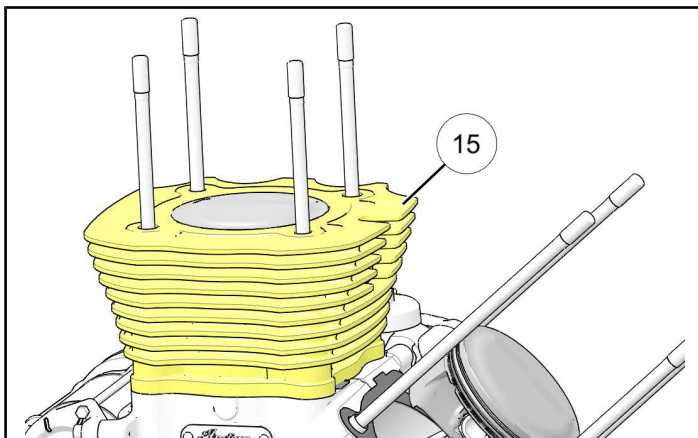

16. Repeat steps 9-14 for other cylinder.

17. Install two new hollow dowels ②⑥ on each cylinder ⑮ as shown. Install two new head gaskets ②② onto cylinders ⑮ as shown. Ensure larger holes in gasket are installed on dowels ②⑥.

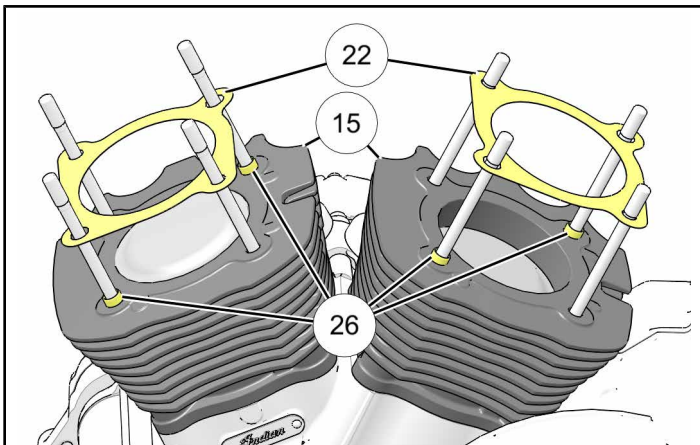

18. Remove and replace push-rod tube O-rings ⑮⑧ on push-rod tubes ⑮⑤.

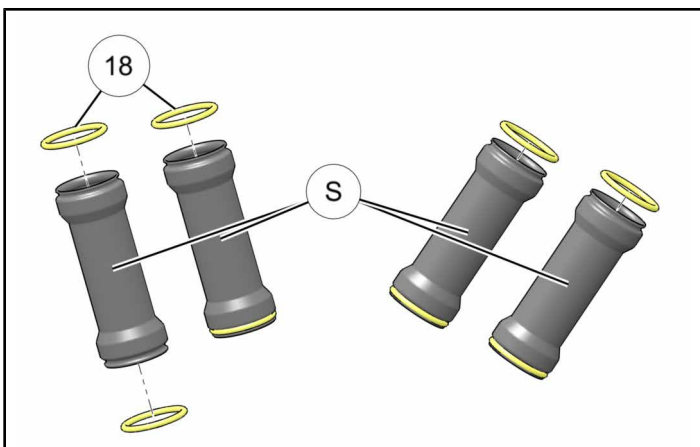

19. Lubricate push-rod tube o-rings ⑮⑧ with engine oil and press push-rod tubes ⑮⑤ into lifter blocks until fully seated.

20. Lubricate cylinder studs with engine oil and set cylinder heads ⑮① in place on cylinder and press down over push-rod tubes ⑮⑤ until fully seated. Install retained washers ⑮② and nuts ⑮③ on cylinder studs. Tighten finger tight.

IMPORTANT

If not seated correctly, O-rings will leak oil. Take special care to ensure O-rings are seated correctly.

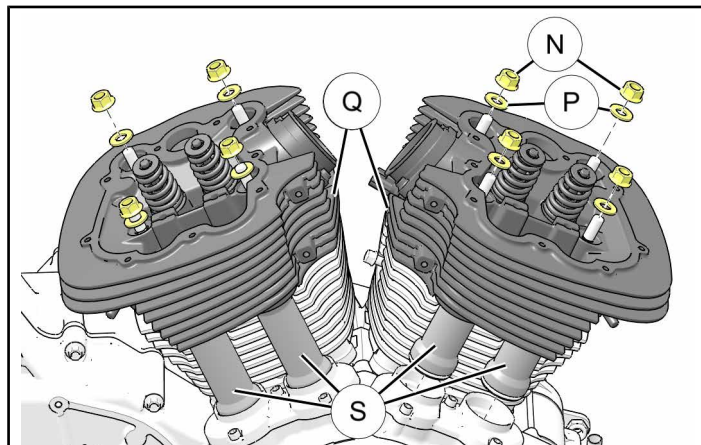

21. Fully torque cylinder heads using a three step process. Follow torque pattern as shown for each step:

TORQUE

Cylinder Head Nuts:

Step 1: 26 ft. lbs. (35 Nm)

Step 2: Turn additional 50°

Step 3: Turn additional 90°

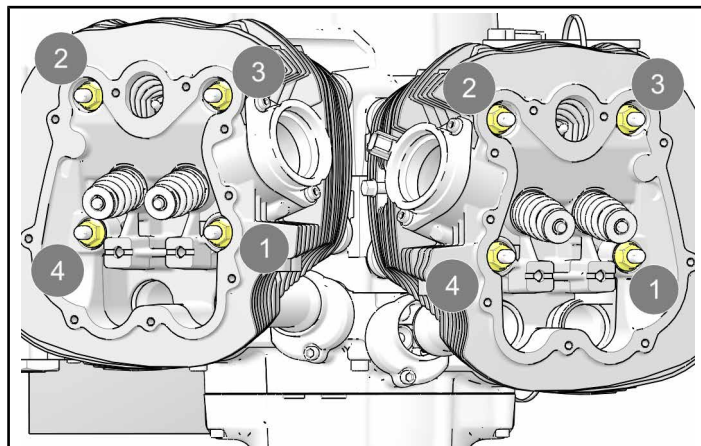

REMOVE PRIMARY COVER AND LOCK CRANKSHAFT

REMOVE PRIMARY COVER

1. Remove and retain clutch arm fastener (A) and clutch arm (B).

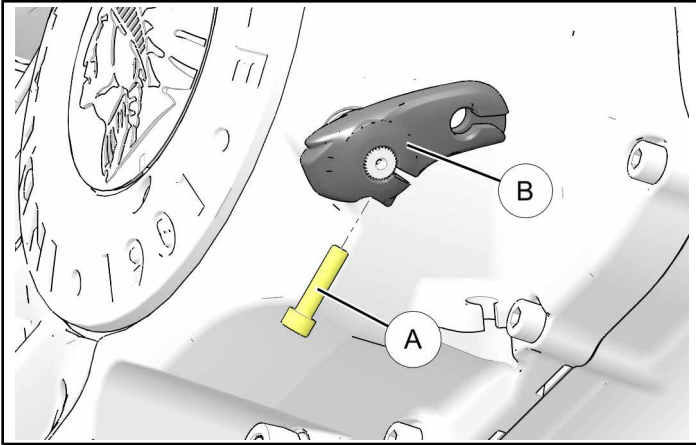

2. Remove and retain shift shaft arm fastener (C) and shift shaft arm (D). Carefully hang shift shaft arm.

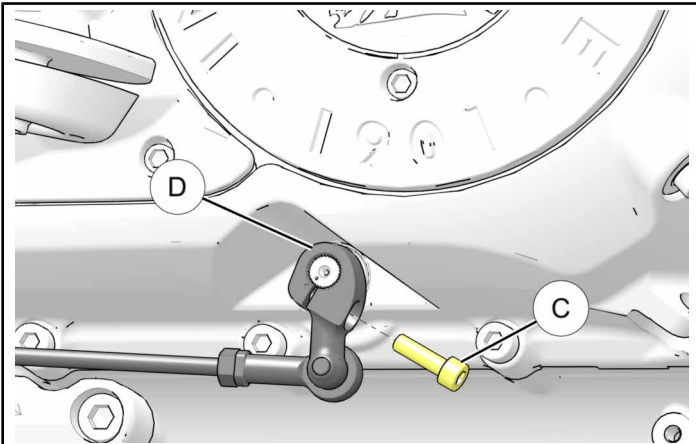

3. Remove and retain seven upper (E) and seven lower (F) primary cover fasteners.

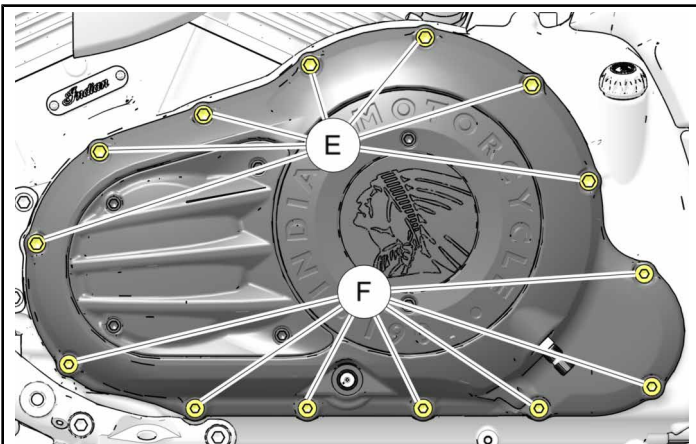

4. Tap cover with a soft face mallet to loosen. Pull primary cover evenly at front and rear of cover to remove.

5. Ensure washer (G) remains in place on shaft after removing primary cover.

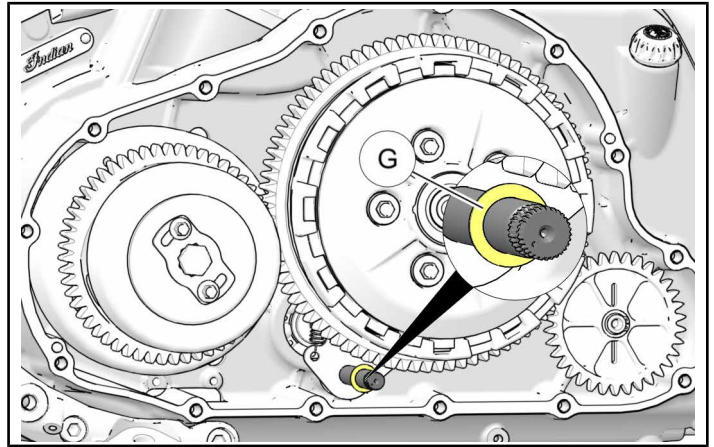

LOCK CRANKSHAFT

1. Perform Crankshaft locking procedure as per Service Manual

REMOVE AND INSTALL CAMSHAFTS

CAM CHAIN, GUIDE AND TENSIONER REMOVAL

1. Remove and retain ten fasteners (A) and (B), make note of different sizes and locations. Remove cam chain cover (C) and gasket.

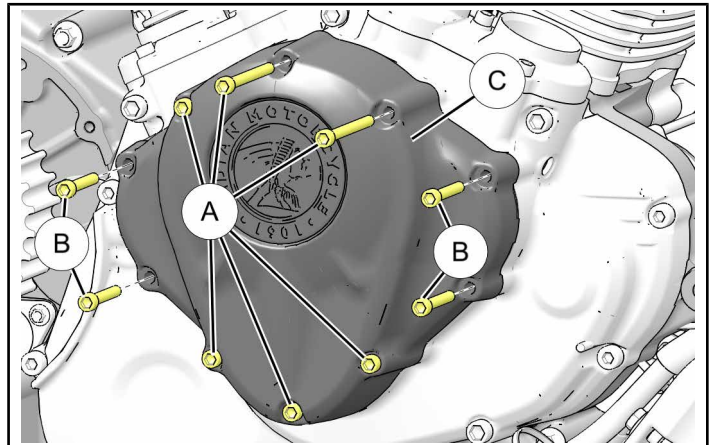

2. Ensure indents on gear faces align with each other as shown. If they do not, repeat crankshaft locking procedure and align them.

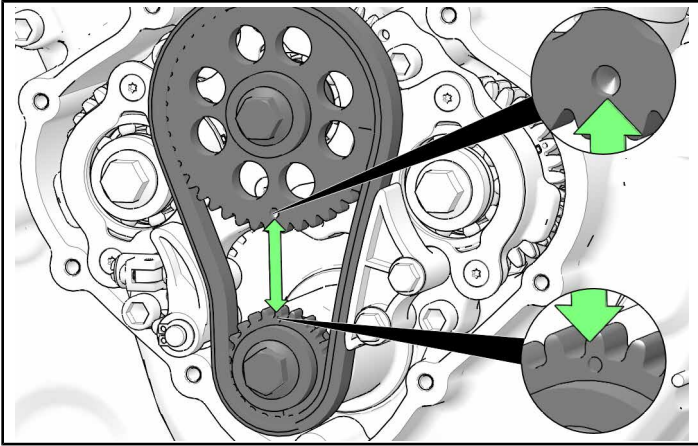

3. Loosen, but **DO NOT REMOVE** four screws ①.

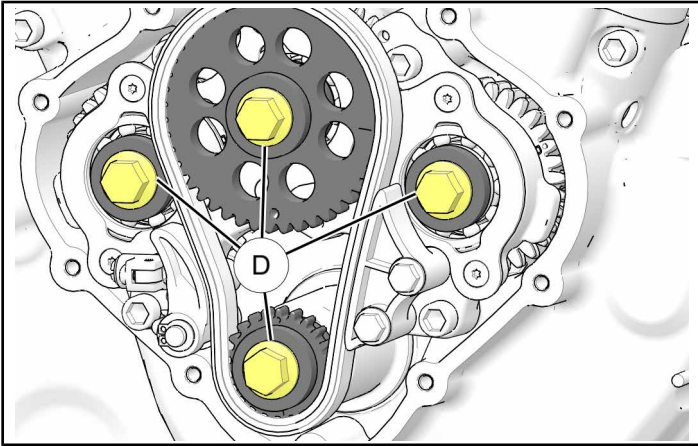

4. Remove and retain chain tensioner fastener ② and chain tensioner ③.

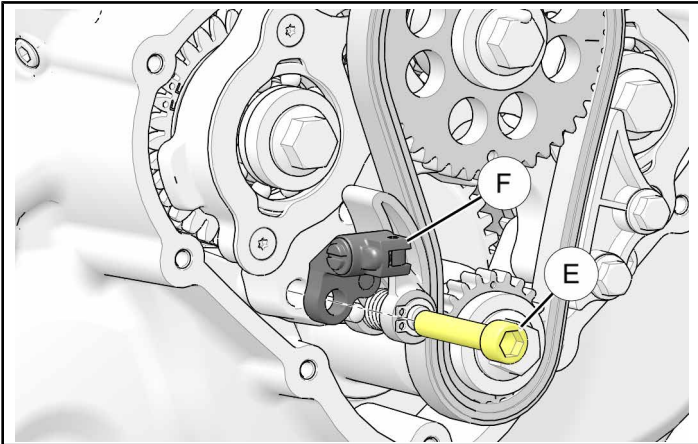

5. Remove and retain external snap ring ④ and chain tensioner arm and spring assembly ⑤.

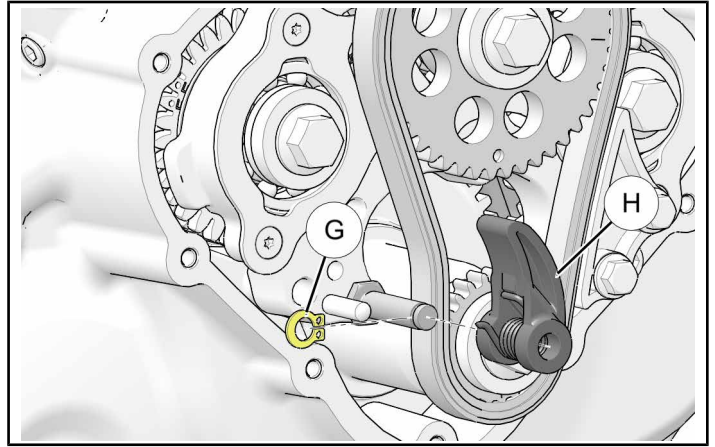

6. Remove and retain two fasteners ⑥ and Camshaft Chain Guide ⑦.

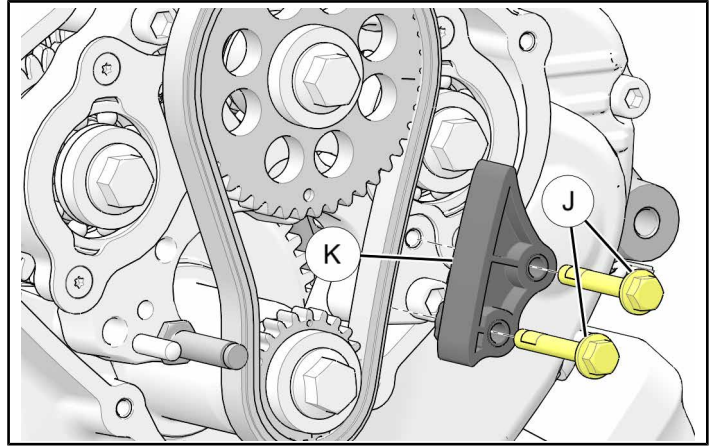

7. Remove screws ① and washers ⑧ from crankshaft and camshaft. Pull camshaft sprocket ⑨, crankshaft sprocket ⑩ and cam chain ⑪ off as an assembly and set aside. Collect woodruff key ⑫ from crankshaft and set aside.

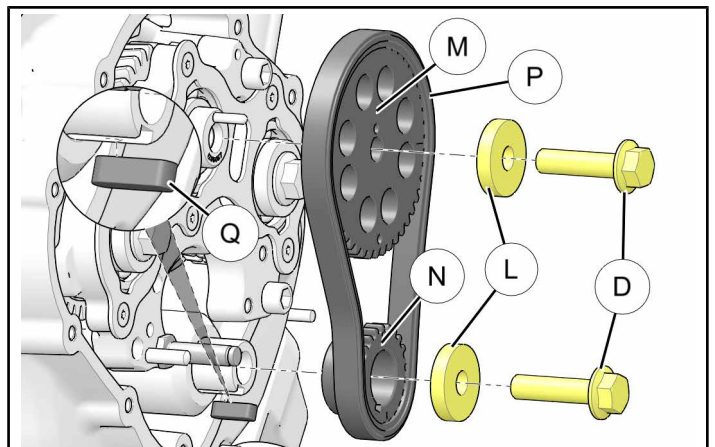

REMOVE AND INSTALL CAMSHAFTS

IMPORTANT

Camshaft removal with cylinder heads torqued in place requires Special Tool: **PF-51455**

1. Remove and install camshafts as per service manual procedure **“CAMSHAFT SERVICE - IN BIKE”**
2. Install new camshafts ③, ④, and ⑤ with new woodruff keys ③① and screws ②⑤ as per service manual procedure.

TORQUE

Camshaft Screws ②⑤: **52 ft. lbs. (70 Nm)**
Camshaft Carrier Fasteners: **15 ft. lbs. (20 Nm)**

CAM CHAIN INSTALLATION

CAUTION

Thunder Stroke is an INTERFERENCE ENGINE. If camshafts and crankshaft must be turned independently of each other to set valve timing, camshafts must be set to TDC prior to rotating crankshaft. Failure to do this may cause pistons to contact valve resulting in engine damage.

1. Verify camshafts are set to TDC.
 - a. Camshaft timing marks ① and ② should be aligned as shown. Camshaft sprocket alignment dowel ③ should be at 12 o'clock as shown.

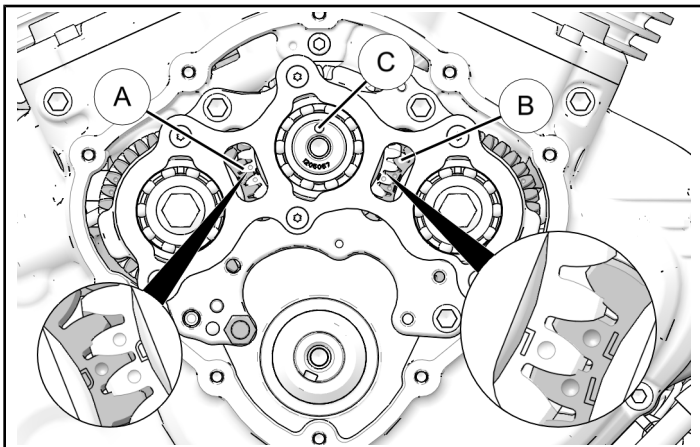

2. Assemble timing chain onto camshaft and crankshaft sprockets.
 - a. Align timing marks ④ as shown.
 - b. Position chain so dark chain links line up with sprocket hashmarks as shown.

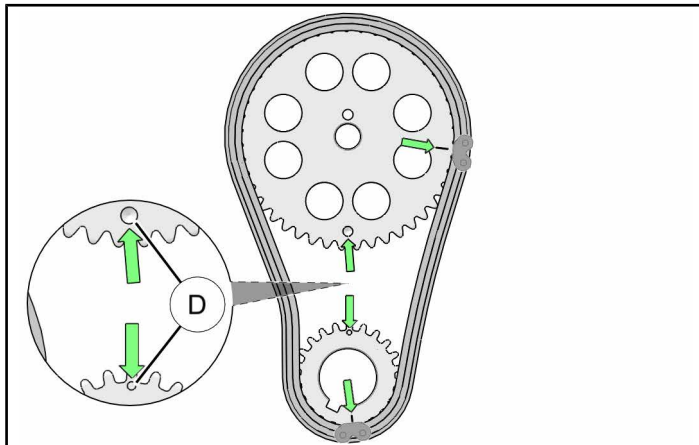

3. Slide chain and sprocket assembly onto crankshaft and center camshaft.
4. Verify crankshaft woodruff key ⑤ is in place and timing marks are aligned.

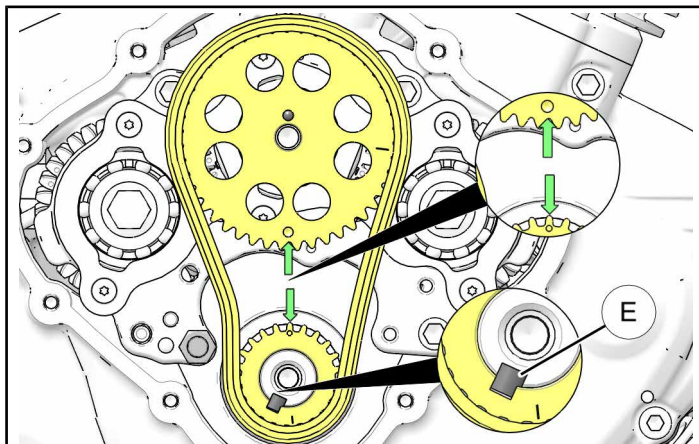

5. Install new crankshaft and camshaft sprocket fasteners and retained washer and torque to specification.

TORQUE

Sprocket Screws ②⑤: **52 ft. lbs. (70 Nm)**

6. Install retained cam chain guide and torque fasteners to specification.

TORQUE

Cam Chain Guide Screws ①: **71 in. lbs. (8 Nm)**

- Install retained cam chain tensioner and tensioner arm assemblies. Torque to specification.

TORQUE

Cam Chain Tensioner Arm Screw (E): **15 ft. lbs. (20 Nm)**

- Clean gasket mating surfaces and install retained cam chain cover with new gasket (21). Torque screws to specification using the following torque sequence.

TORQUE

Cam Chain Cover Screw (A): **10 ft. lbs. (13 Nm)**

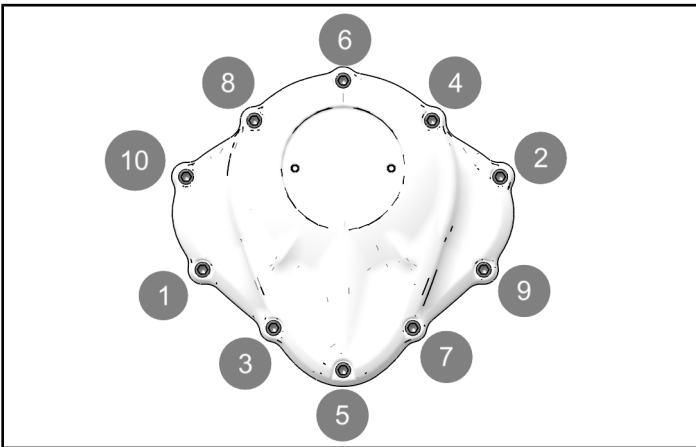

REPLACE CLUTCH SPRINGS

NOTE

Replace clutch springs one at a time so clutch pack removal is not needed.

- With clutch assembly (A) still installed, remove and retain one pressure plate fastener (B), remove one clutch spring (C), and replace with a new clutch spring (22). Reinstall screw (B) and torque to specification.

TORQUE

Clutch Spring Screw (B): **89 in. lbs. (10 Nm)**

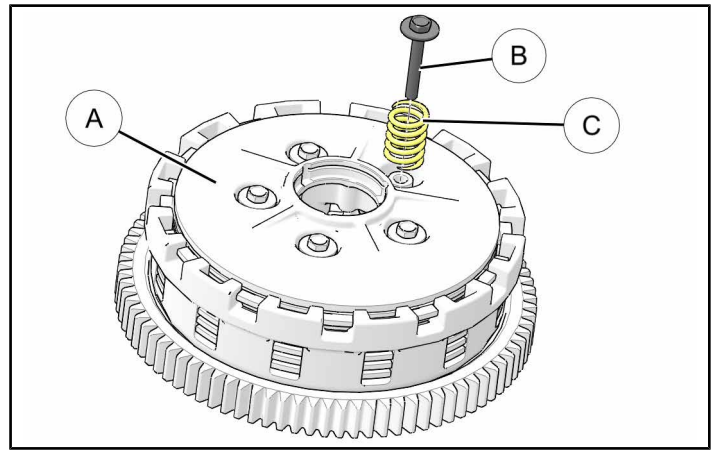

- Repeat procedure for other four clutch springs, replacing them one at a time.

REASSEMBLY

LOWER ENGINE REASSEMBLY

- Remove crankshaft locking pin installed during locking procedure.
- Install stator as per service manual procedure.
- Install flywheel as per service manual procedure.
- Install torque compensator as per service manual procedure.
- Clean gasket surfaces of crankcase and primary cover.
- Ensure thrust washer is installed on shift shaft (as shown in **step 4** of **Remove Primary Cover** section).
- Install new primary cover gasket (20).
- Apply a thin layer of grease to shift shaft seal.
- Install primary cover as per service manual procedure.

- Torque primary cover fasteners to specification following torque sequence.

TORQUE

Primary Cover Screws ③ and ④: **15 ft. lbs. (20 Nm)**

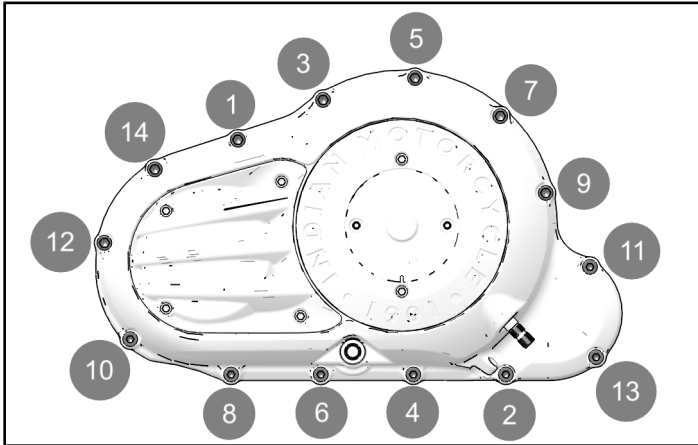

UPPER ENGINE REASSEMBLY

NOTE

Ensure wire routings are clear of sharp edges and heat sources when installing. Refer to notes taken during disassembly and reinstall **ALL** cable ties and clips to original locations.

- Reinstall retained push-rods ① into tubes. Reinstall rockers ② into original locations and torque rockers to specification.

TORQUE

Rocker Arms ②: **22 ft. lbs. (30 Nm)**

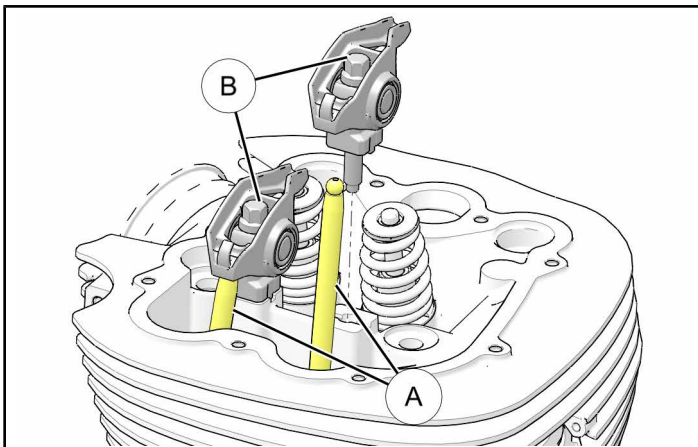

- Replace valve cover gaskets with new gaskets ⑲.

- Install front ③ and rear ④ valve covers with retained bolts ⑥. Tighten bolts finger tight, then torque to specification following torque sequence.

TORQUE

Lower Valve Cover Screws ⑥: **89 in. lbs. (10 Nm)**

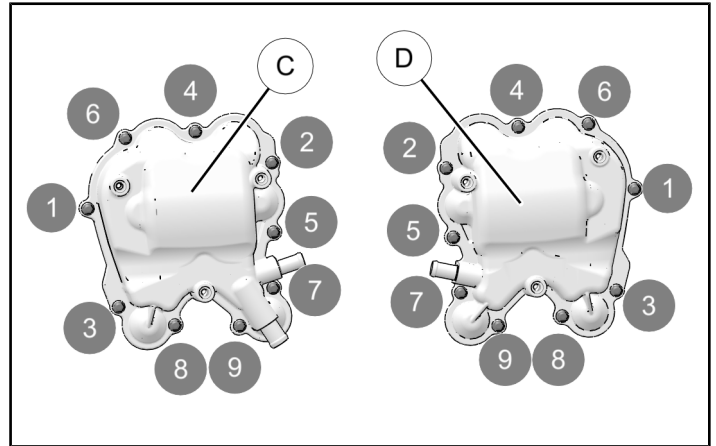

- Install retained intake manifold ⑤ with retained hose clamps ⑥.

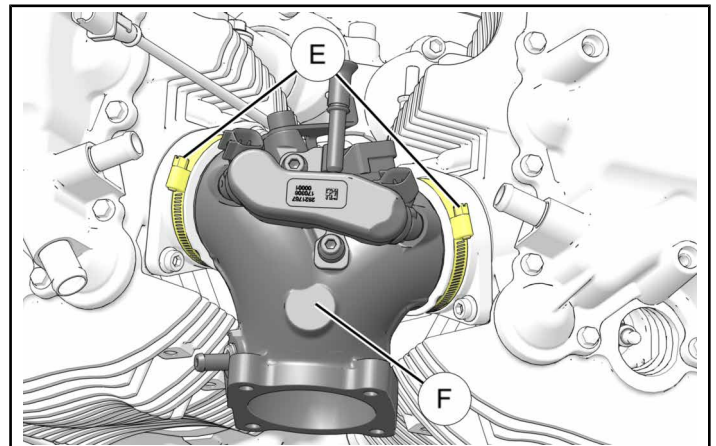

5. Install upper valve covers and breather hose (G) with six retained screws (H). Torque upper valve cover screws to specification.

TORQUE

Upper Valve Cover Screws (H): **89 in. lbs. (10 Nm)**

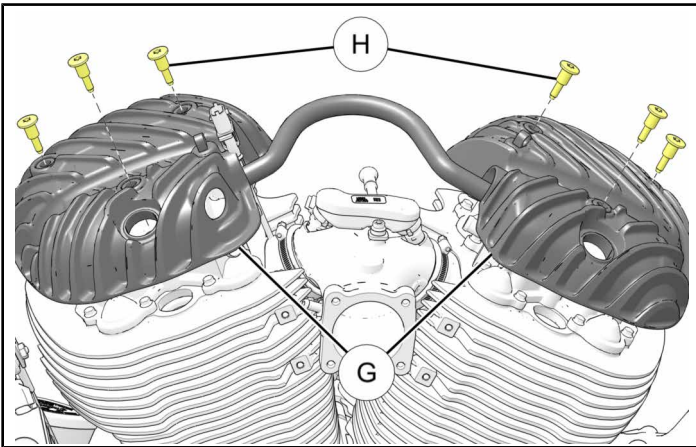

AIRBOX/THROTTLE BODY INSTALLATION

1. Install retained bracket (A) with four retain fasteners (B). Torque fasteners to specification.

TORQUE

Bracket Fasteners (B): **88 in. lbs. (10 Nm)**

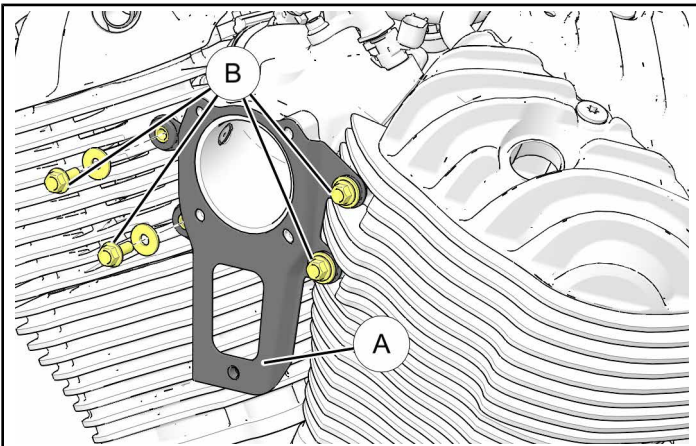

2. Before installing **Stage 1 High Performance Air Cleaner Kit** (PN 2881779-XXX). Remove and discard hard plastic spacer (X).

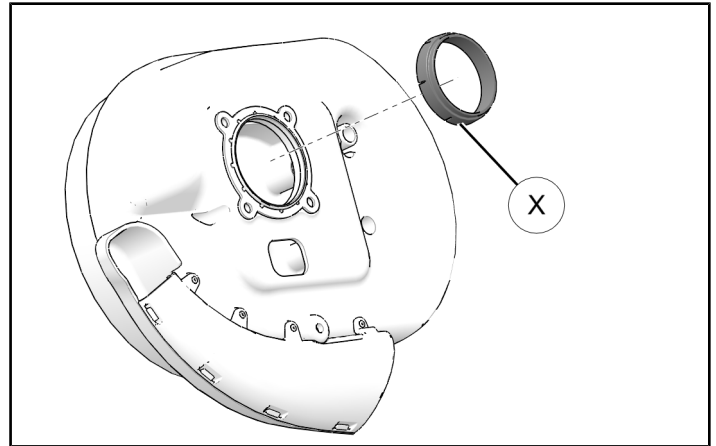

3. Feed throttle body electrical connector (C) through hole in airbox (D) and install rubber harness seal (E) in rectangular cutout.

NOTE

Ensure harness seal is fully seated in airbox.

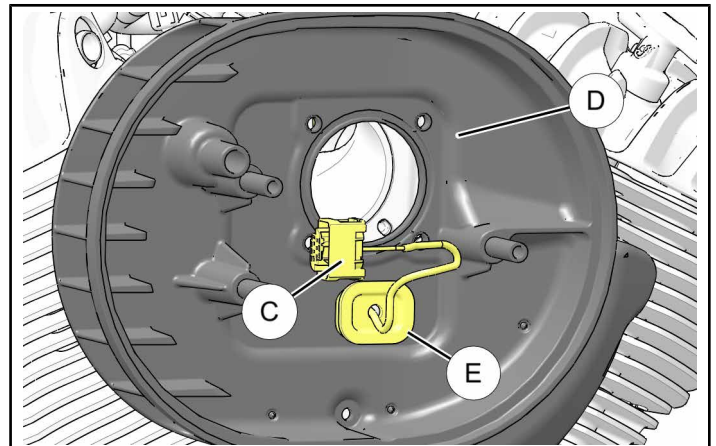

4.

IMPORTANT

Ensure proper airbox gasket is used with corresponding airbox.

- Stage 1 High Performance Air Cleaner Kit (PN 2881779-XXX) (Oval Airbox)
 - Airbox Gasket (N) PN 5633638 (Included in Airbox Kit)
- Performance Airbox Kit (PN 2880654-XXX) (Round Airbox)
 - Airbox Gasket (19) PN 5633754 (Included in Stage 3 116 Kit PN 2883921)

Install new airbox gasket (19) or (N) with inner gasket lip extending into intake (as shown with inset and arrow) between intake manifold (14) and airbox (D) (Airbox may vary from image based on which kit is equipped). Loosely install airbox (D) to intake manifold (14). Ensure breather hose (F) is connected to airbox (D).

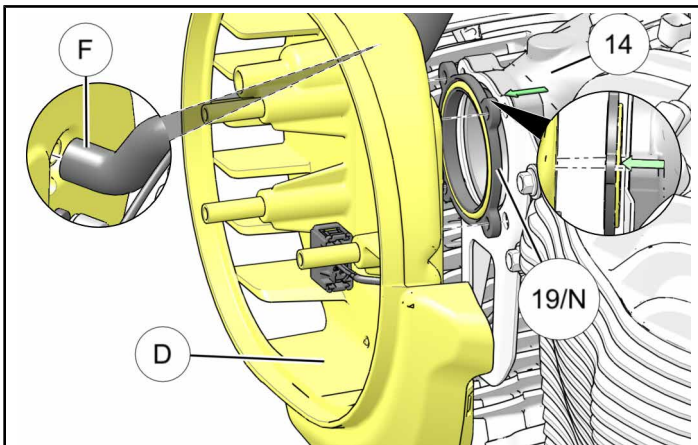

5. Install retained throttle body gasket (G) and new throttle body (2) using four retained screws (H). Plug throttle valve connector (C) into throttle valve. Torque screws to specification.

TORQUE

Throttle Valve Screws (H): **88 in. lbs. (10 Nm)**

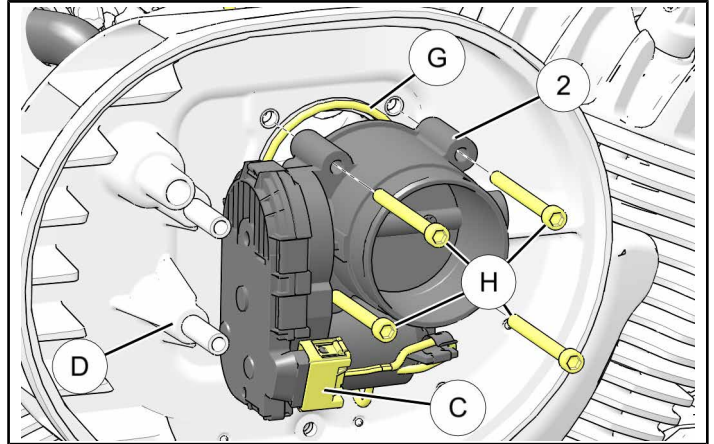

6. Complete installation of airbox using kit instructions for equipped airbox (PN 2881779-XXX or 2880654-XXX)
7. Reconnect any ignition wires, hoses, or any other connections on top of engine.
8. Reinstall ignition coil as per service manual procedure.

INSTALL ENGINE

1. Perform engine installation completely as per service manual procedure.

IMPORTANT

Ensure wire routings are clear of sharp edges and heat sources when installing. Refer to notes taken during disassembly and reinstall **ALL** cable ties and clips to original locations.

NOTE

Stage 1 Muffler Kit (PN 2879529-XXX, 2879768-XXX, or 2879769-XXX) must be installed and not stock exhaust.

2. Replace engine oil with new, clean oil (either Indian® 20W-40 or Indian® 15W-60 Engine Oil) and replace oil filter with new Indian® oil filter.
3. Use dipstick to check engine oil level and add recommended oil, if necessary.
4. Remove spark plugs.
5. Turn engine over several times with starter motor to pump up oil into engine.

6. Reinstall and torque spark plugs.

TORQUE

Spark Plugs: **13ft. lbs (17 Nm)**

REPLACE BADGES

IMPORTANT

- Installation temperature must be between 70-100° F (21-37° C)
- Clean surfaces are critical for adhesion performance.
- Backing liners should not be removed until part is going to be applied.

NOTE

Clean surfaces no more than 20 minutes prior to installation.

⚠ WARNING

Isopropyl alcohol is hazardous to your health. See isopropyl packing for proper handling instructions, including recommended personal protective equipment such as goggles and chemical resistant gloves.

1. Carefully remove Cam Cover badge ① and Primary Cover badge ② with non-marring tool.

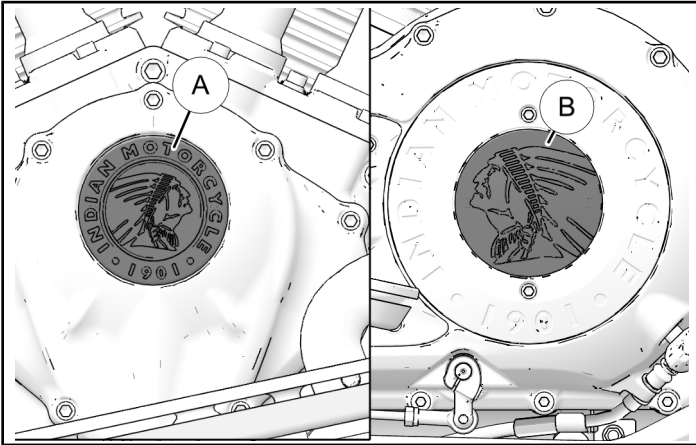

2. Clean adhesive from covers with solvent wipes.
3. Remove backing paper from badges and apply to corresponding locations. Apply firm pressure over entire badge surface for proper adhesion.

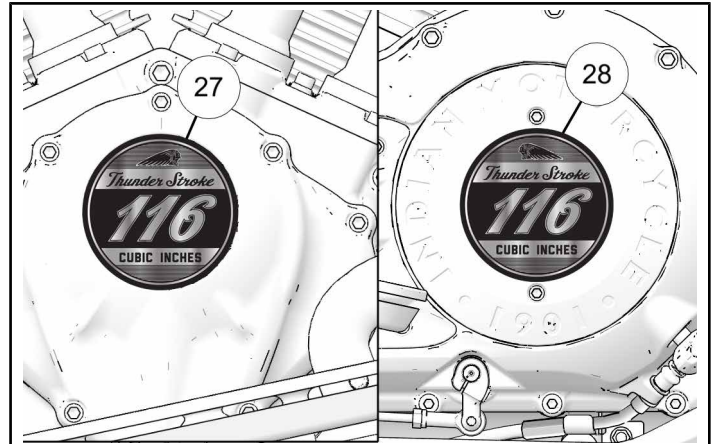

UPDATE ECM

1. Update ECM with new calibration software using included Calibration Card ③.

IMPORTANT

This step must be completed by an Authorized Indian Dealer. Do not operate vehicle until re-calibration of vehicle is complete.

FEEDBACK FORM

A feedback form has been created for the installer to provide any comments, questions or concerns about the installation instructions. The form is viewable on mobile devices by scanning the QR code or by clicking [HERE](#) if viewing on a PC.

FEEDBACK FORM

