

FENDER ORNAMENT KIT



P/N 2880665-XXX, 2884446-XXX

APPLICATION

Verify accessory fitment at www.indianmotorcycle.com.

BEFORE YOU BEGIN

Read these instructions and check to be sure all parts and tools are accounted for. Please retain these installation instructions for future reference and parts ordering information.

KIT CONTENTS

NOTE

XXX = Indian Motorcycle® color code (For example: 266 = Black)

HEADRESS LIGHT KIT, P/N 2880665-XXX

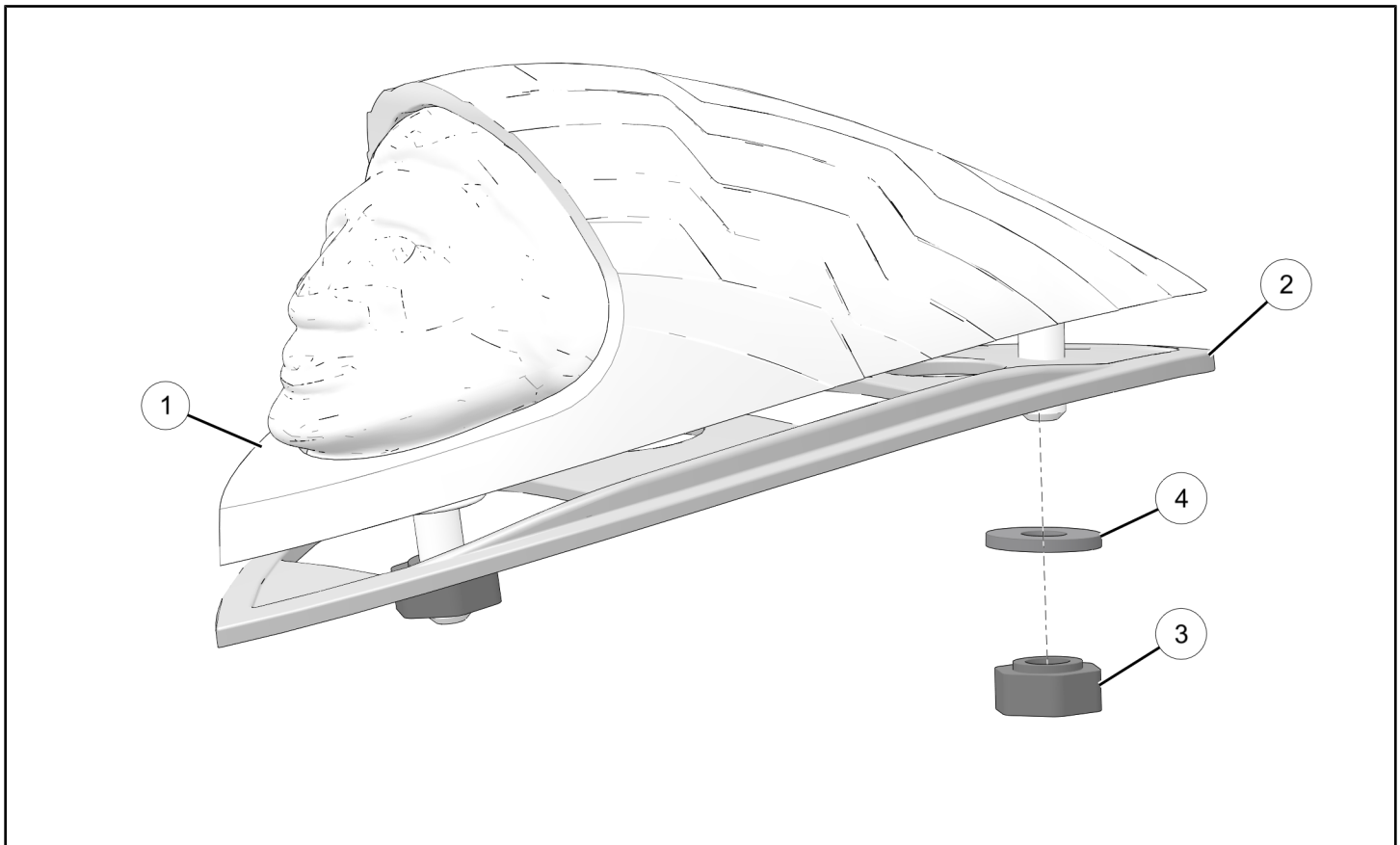

REF	QTY	PART DESCRIPTION	P/N AVAILABLE SEPARATELY
1	1	Assembly-Light, Headdress	2412441-XXX
2	1	Gasket-Headdress	5414721
3	2	Nut-Hex Flange, M6 x 1.0	7547453
4	2	Washer-0.234 in x 0.593 in	n/a

FENDER FIN KIT, P/N 2884446-XXX

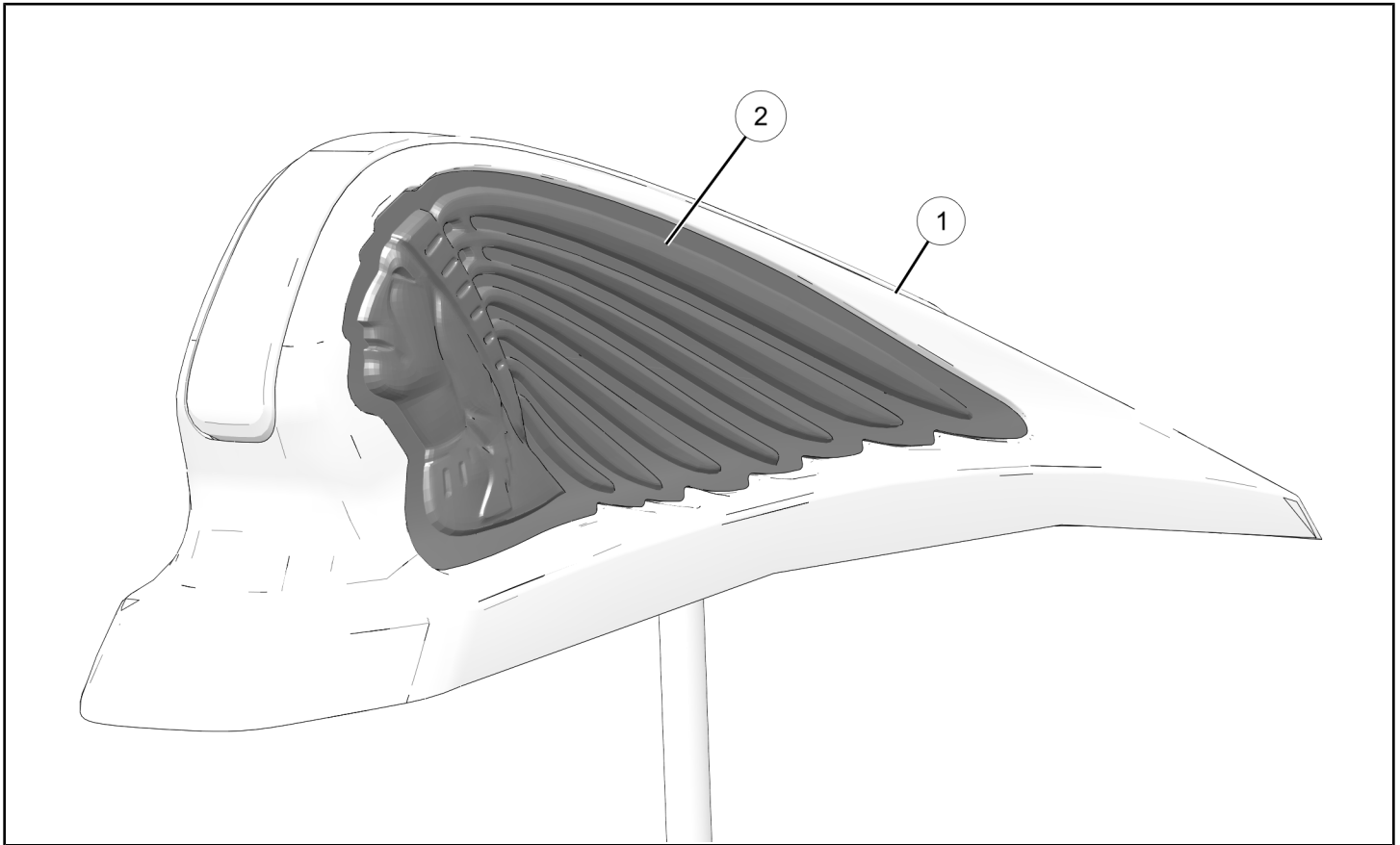

REF	QTY	PART DESCRIPTION	P/N AVAILABLE SEPARATELY
1	1	Assembly-Light, Fin-Head	2415315-XXX
2	1	Decal-Headdress, Left-Hand	7191121-XX
3	1	Decal-Headdress, Right-Hand (not shown)	7191122-XX
4	3	Cable Tie (not shown)	7080138

TOOLS REQUIRED

- Safety Glasses
- Hex Key Set, Metric
- Pliers, Side Cutting
- Socket Set, Hex Bit, Metric
- Socket Set, Metric
- Torque Wrench
- **Special Service Tool:**
 - Non-marring Pry Tool, P/N 5456907 (or equivalent)

IMPORTANT

Your Indian Motorcycle® Fender Ornament Kit is exclusively designed for your vehicle. Please read the installation instructions thoroughly before beginning. Installation is easier if the vehicle is clean and free of debris. For your safety, and to ensure a satisfactory installation, perform all installation steps correctly in the sequence shown.

INSTALLATION INSTRUCTIONS: HEADRESS LIGHT KIT, P/N 2880665-XXX

NOTICE

The following procedures apply only to 2014 and newer Chief®, Chieftain®, Springfield®, and Roadmaster® models.

VEHICLE PREPARATION

GENERAL

1. Turn key or ignition switch to OFF position and remove key.
2. Ensure motorcycle is parked on a flat surface, kickstand is fully extended, and vehicle is stable prior to installation.

CLOSED FENDER REMOVAL

NOTICE

Motorcycle should be parked on level surface, resting on side stand.

CAUTION

Use care to not scratch or damage painted surfaces during fender removal.

1. Remove two acorn nuts and one fastener from each side of front fender to remove caliper covers.

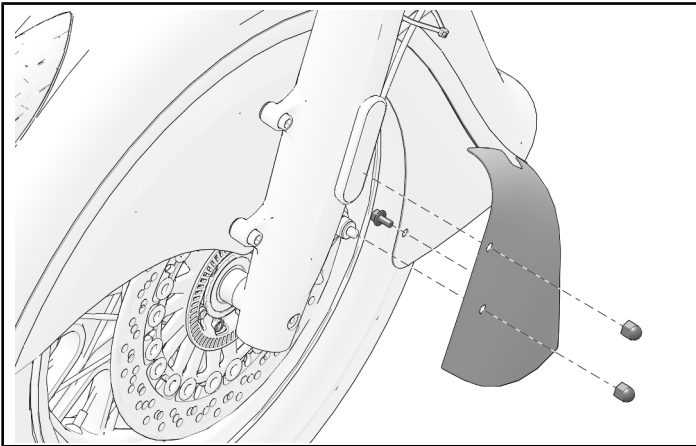

2. Disconnect fender light. Note location of cable ties before removing cable ties.

3. Remove three fasteners from each side of fender.

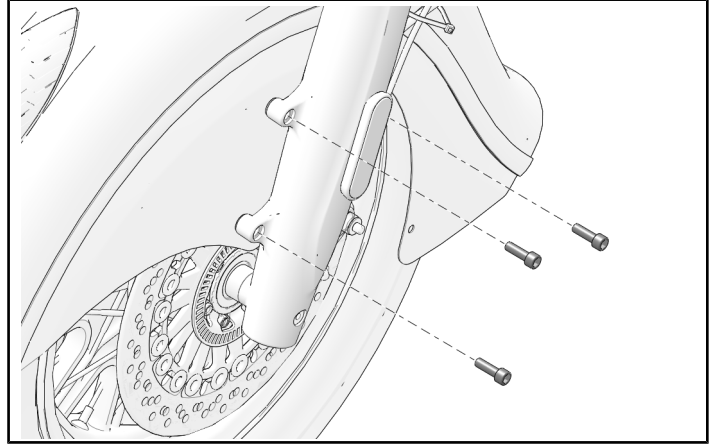

4. Facing front fender, squeeze each side together while rotating fender forward from between forks.

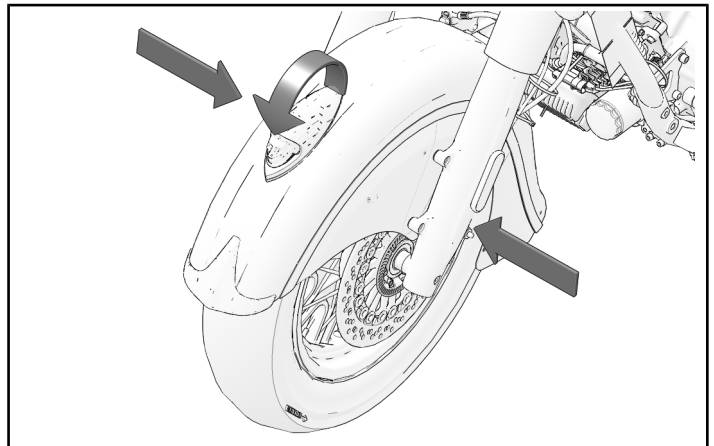

5. If reinstalling fender, store safely until it is reinstalled.

ACCESSORY INSTALLATION

CAUTION

Place fender on soft surface to prevent damage to painted finish during light installation.

1. Remove two nuts from underside of fender to remove fender ornament.

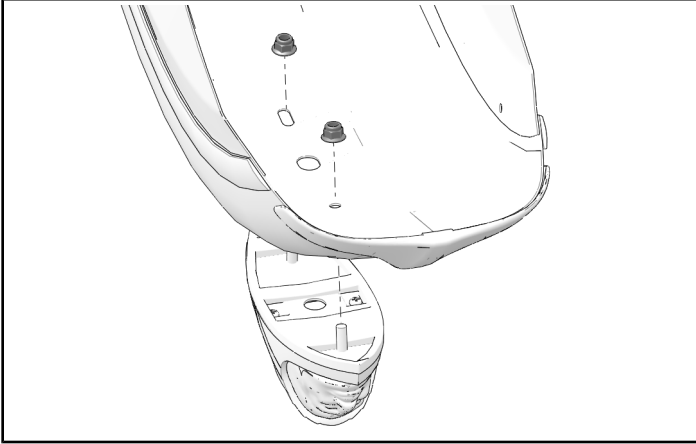

2. Pass light harness through gasket ② and seat light assembly ① on gasket.

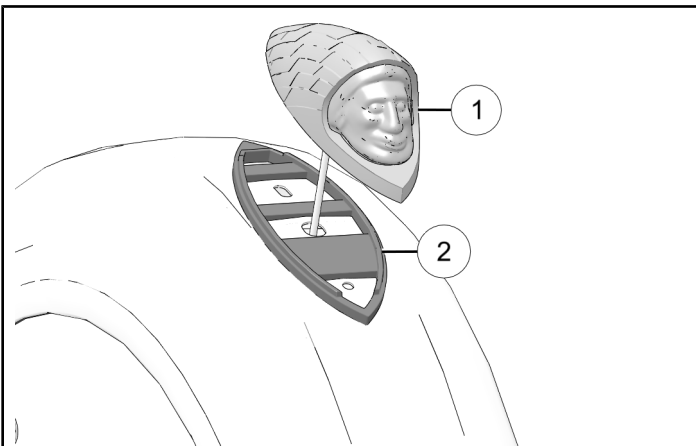

3. Secure light assembly to fender with two washers ④ and two nuts ③.

TORQUE

Light Assembly Nuts:
25 in-lbs (3 N·m)

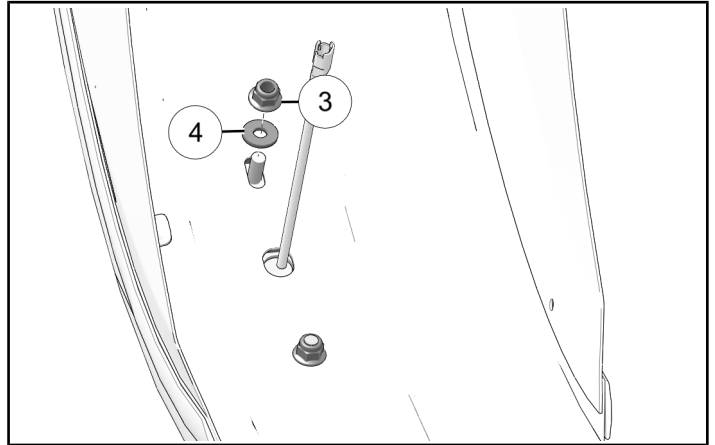

VEHICLE REASSEMBLY

CLOSED FENDER INSTALLATION

NOTICE

Motorcycle should be parked on level surface, resting on side stand.

CAUTION

Use care to not scratch or damage painted surfaces during fender removal.

1. Facing front fender, squeeze each side together while rotating fender between forks.

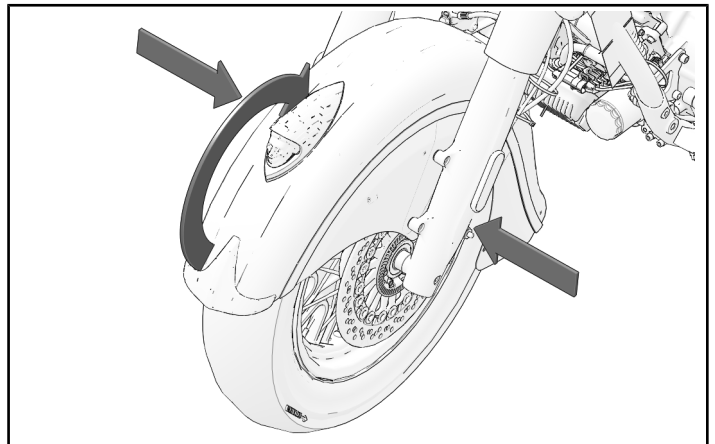

2. Install fender with three fasteners on each side.

TORQUE

Front Fender Fasteners:
18 ft-lbs (24 N·m)

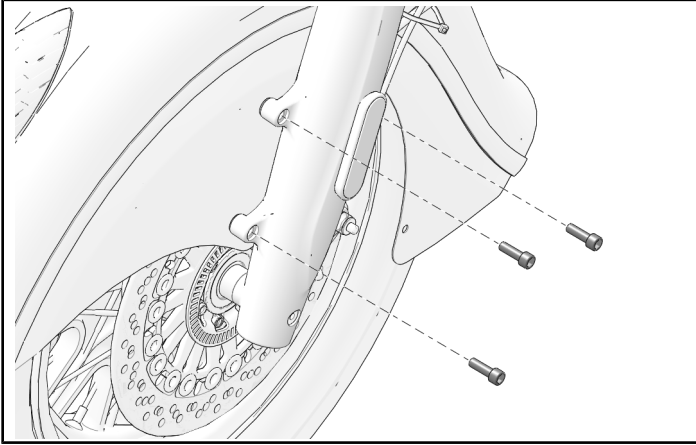

3. Connect fender light to chassis harness. Secure with cable ties, as needed.
4. Install caliper covers with two acorn nuts and one fastener on each side.

TORQUE

Caliper Cover Acorn Nuts:
18 in-lbs (2 N·m)

TORQUE

Caliper Cover Fasteners:
84 in-lbs (9.5 N·m)

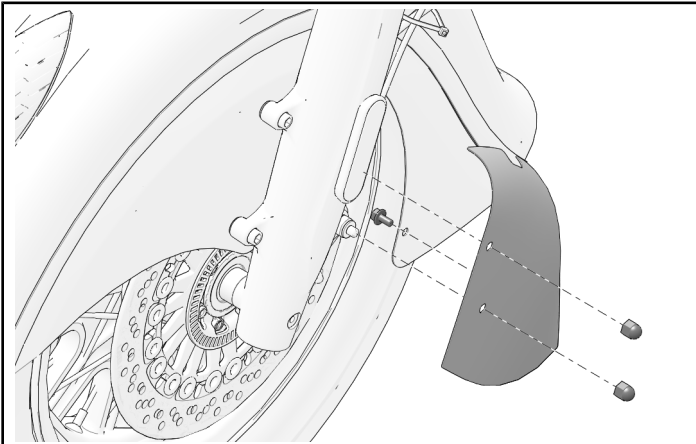

INSTALLATION INSTRUCTIONS: FENDER FIN KIT, P/N 2884446-XXX

NOTICE

The following procedures apply only to 2020 and Newer Challenger models.

VEHICLE PREPARATION

GENERAL

1. Turn key or ignition switch to OFF position and remove key.
2. Ensure motorcycle is parked on a flat surface, kickstand is fully extended, and vehicle is stable prior to installation.

OUTER FAIRING REMOVAL

1. Open storage doors (A) and pull out storage liners (B). Set liners aside.

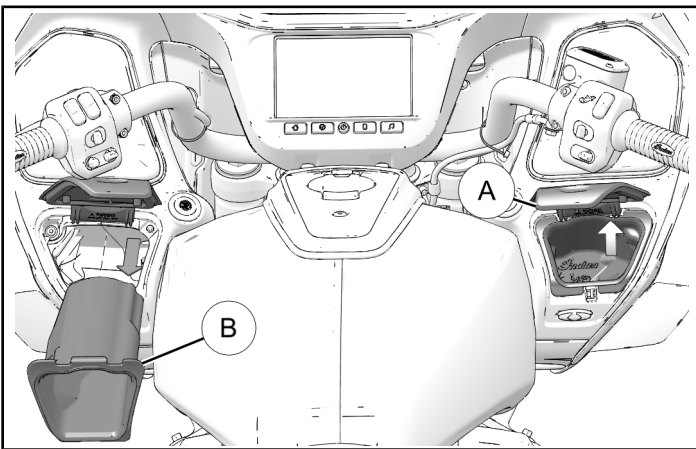

2. Carefully pry along edge with non-marring pry tool to disengage speaker grill assemblies (C).

TIP

Use Special Tool:
Non-marring Pry Tool, P/N 5456907 (or equivalent)

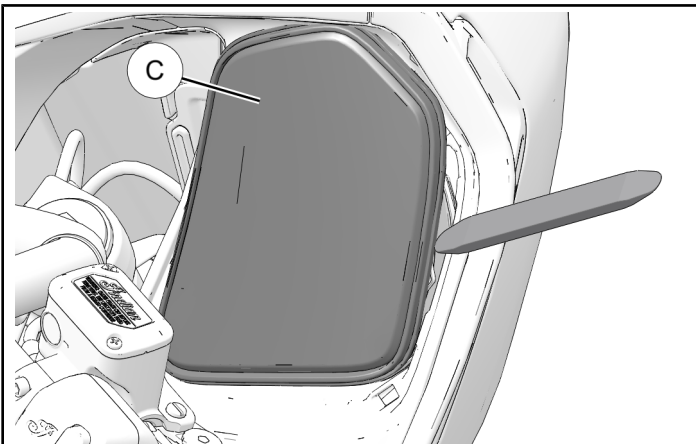

3. Gently pry along top edge of headlight bezel (D) with non-marring pry tool. Pull headlight bezel (D) down and out. Carefully set aside.

TIP

Use Special Tool:
Non-marring Pry Tool, P/N 5456907 (or equivalent)

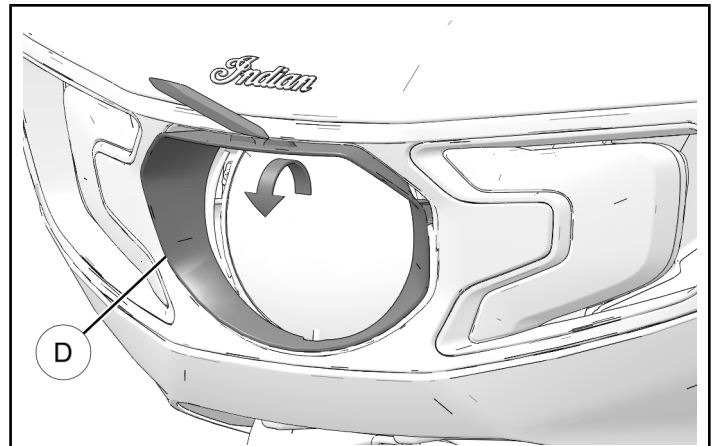

4. Remove and retain three screws (E) from around headlight bezel as shown.

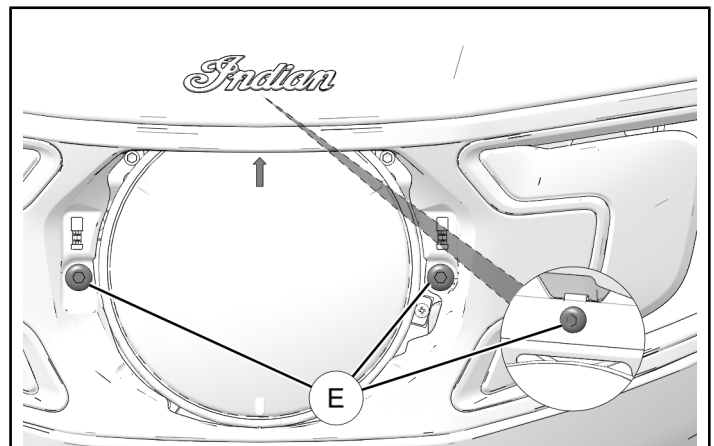

- Remove and retain two screws (F) from top outer corner of storage openings and two screws (F) from top center of speaker openings.

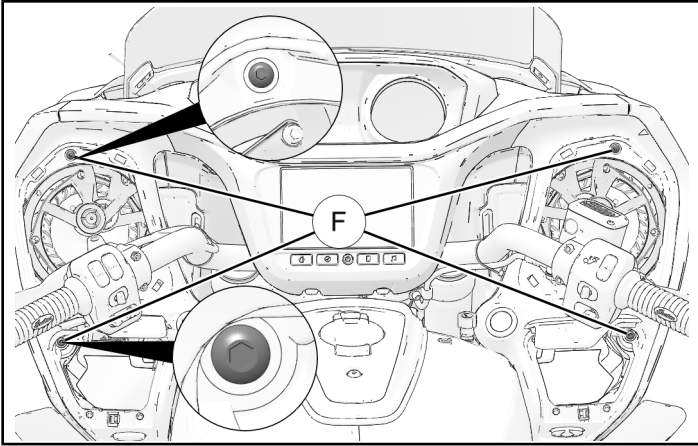

- Remove and retain one screw (G) from under edge of each side of fairing as shown.

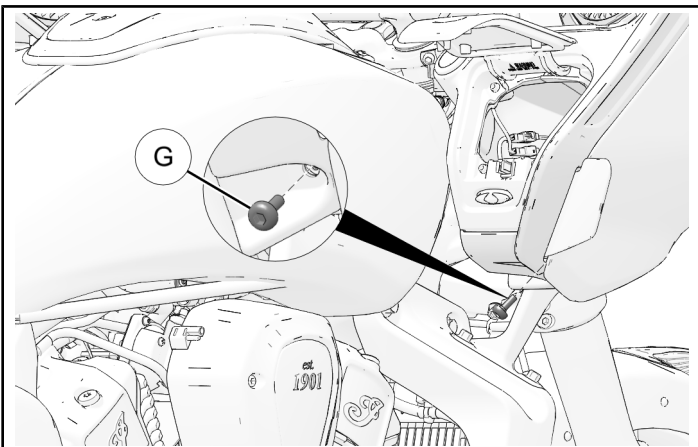
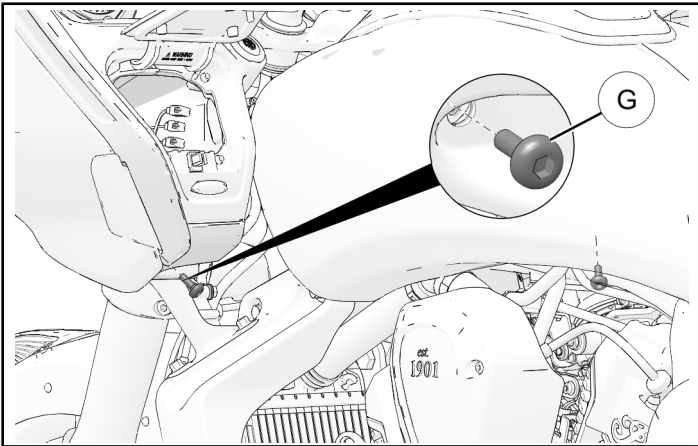

- Pull fairing outward at top to disengage. Pull fairing out a short distance and disconnect headlight and turn signal wire connectors.

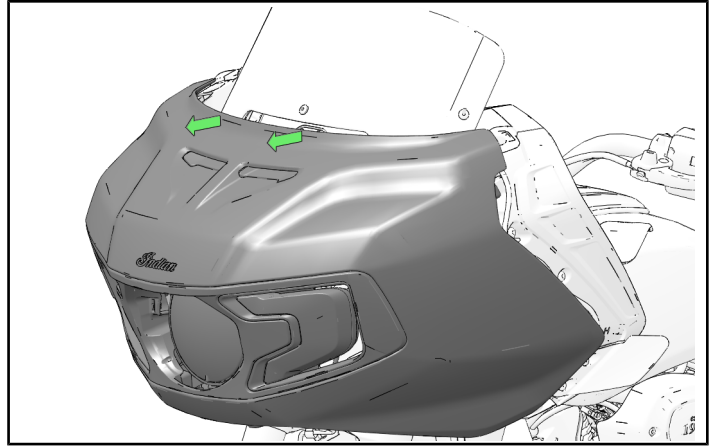

- Disconnect connectors for headlight (H) and turn signals (J).

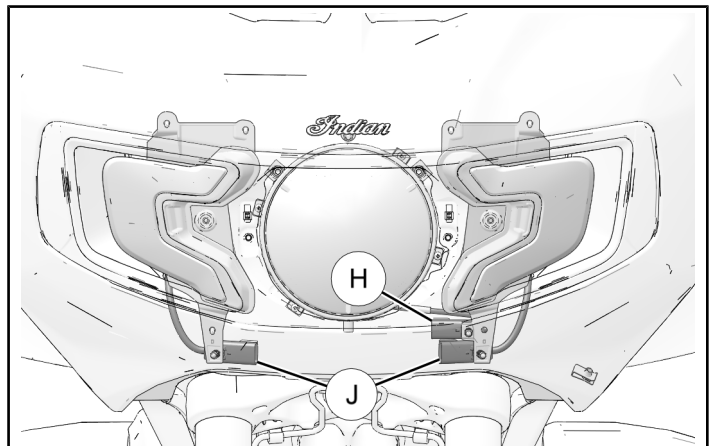

- Carefully pull outer fairing off motorcycle and set aside.

FRONT FENDER REMOVAL

NOTE

Models equipped with an illuminated fender ornament will require the light harness to be disconnected. Remove outer fairing to access electrical connection before proceeding with front fender removal procedures.

CAUTION

Use care not to scratch or damage painted surfaces during fender removal.

- Follow fender light harness up into fairing, locate and disconnect connector.

2. Remove two fasteners from each side of front fender.

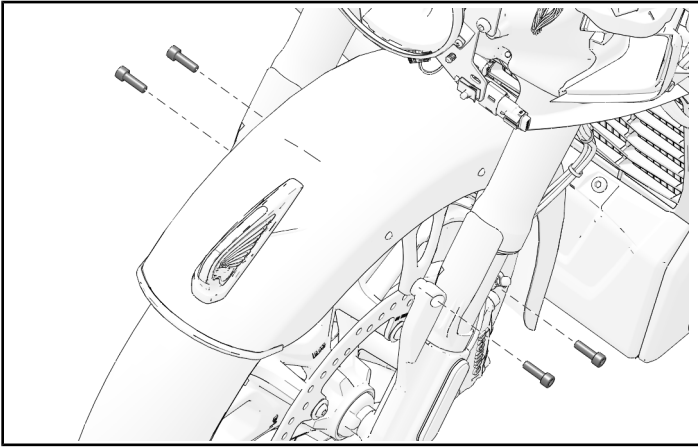

2. Remove light harness from fender channel and harness tray.

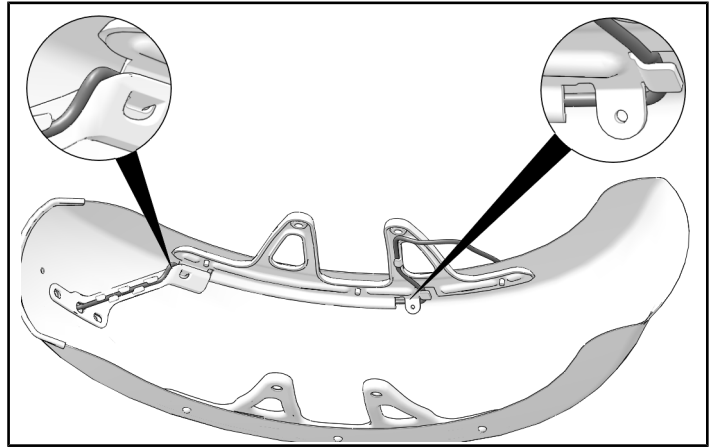

3. Carefully, rotate fender forward and remove.

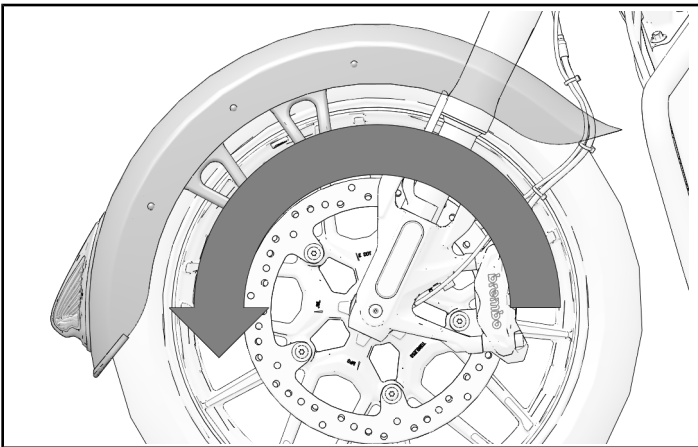

3. Remove fender light while feeding harness out through fender. Retain gasket.

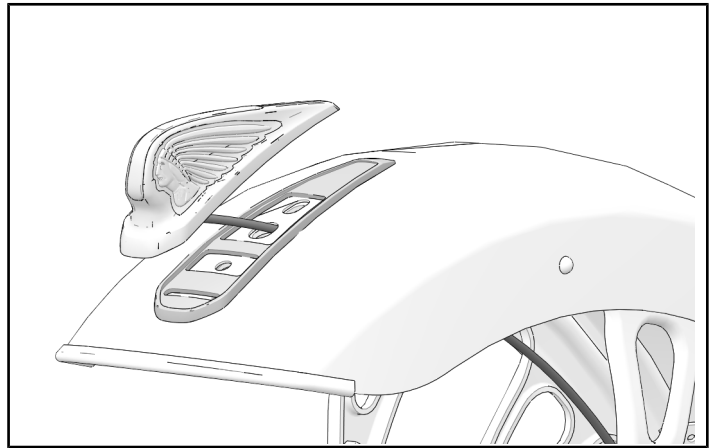

4. If reinstalling fender, store safely until it is reinstalled.

ACCESSORY INSTALLATION

STOCK FENDER LIGHT REMOVAL

1. Remove and retain two fender light fasteners from underside of fender assembly.

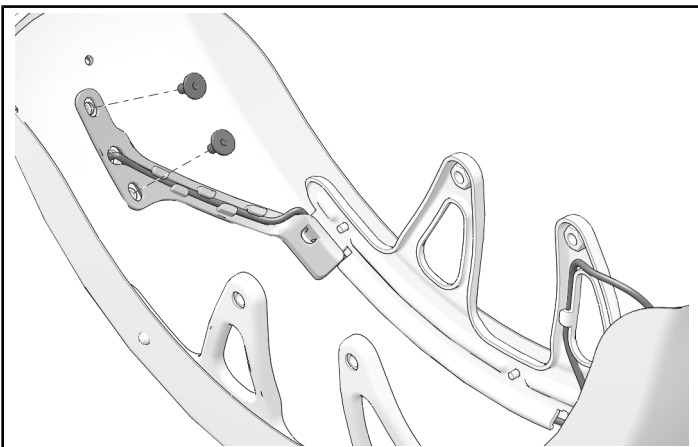

ACCESSORY FENDER LIGHT INSTALLATION

1. Align accessory fender light with gasket and pass harness through gasket and fender.

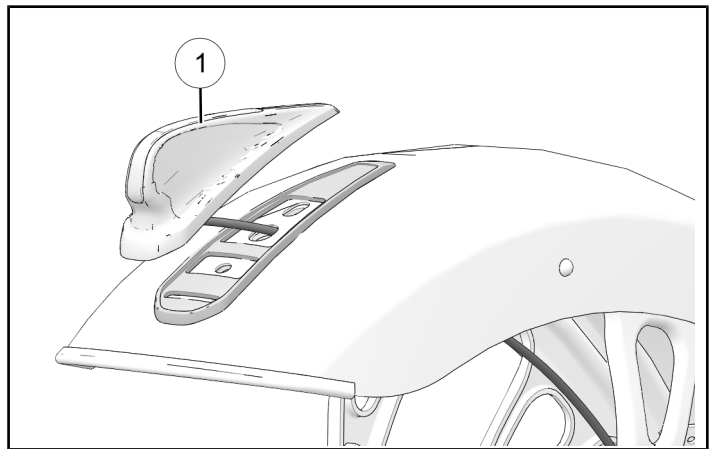

2. Route harness through harness tray.

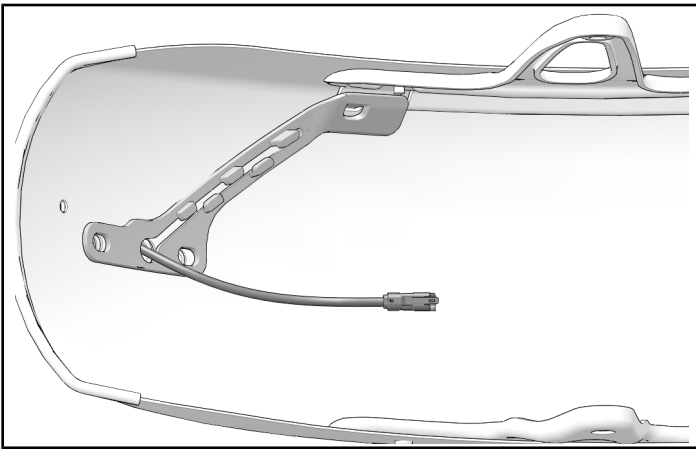

3. Install light with two retained fasteners.

TORQUE

Fender Light Fastener:
36 in-lbs (4 N·m)

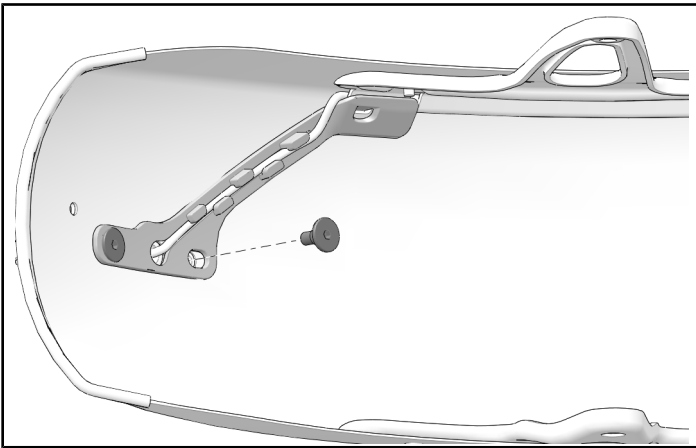

4. Route light harness in harness tray and into fender channel.

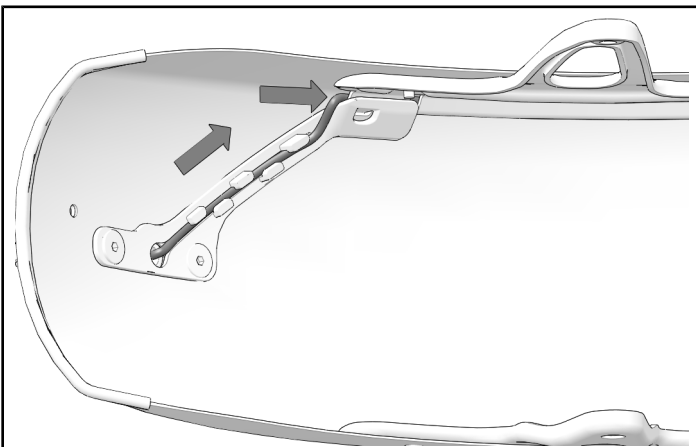

5. Continue to route harness along channel and along fender bracket. Secure harness tray clip to fender channel after harness is routed.

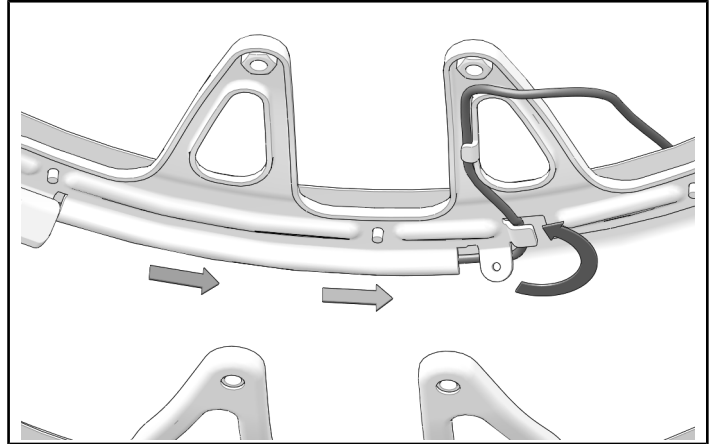

VEHICLE REASSEMBLY

FRONT FENDER INSTALLATION

CAUTION

Use care not to scratch or damage painted surfaces during fender removal and / or installation.

1. Ensure fender light harness is properly routed in fender channel.
2. Carefully, rotate fender rearward and into installed position.

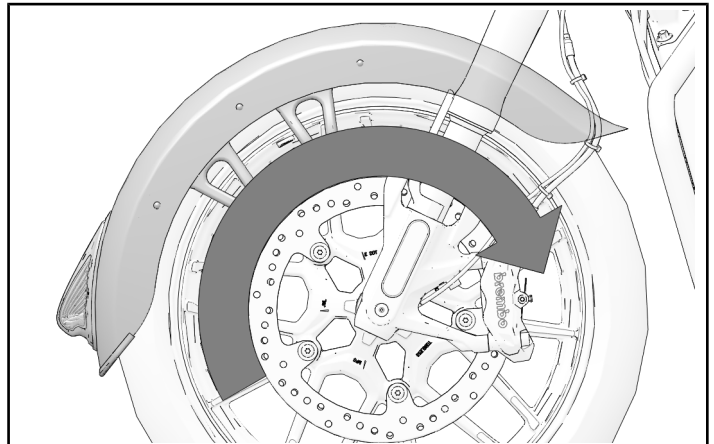

3. Route fender light harness along brake line and secure with cable ties. Connect fender light harness to chassis harness, behind fairing.

4. Install fender with four front fender fasteners.

TORQUE

Front Fender Fasteners:
18 ft-lbs (24 N·m)

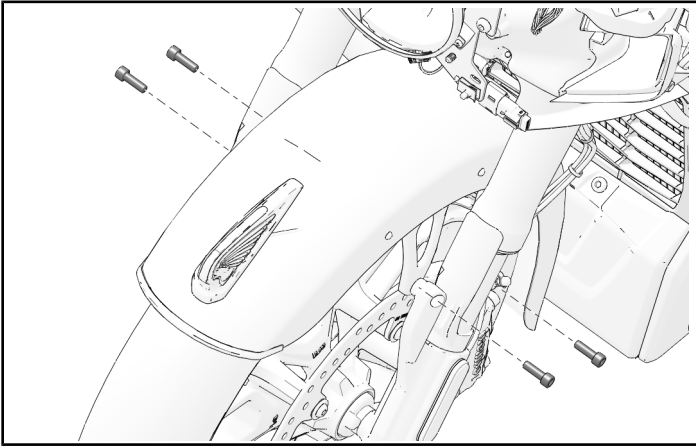

OUTER FAIRING INSTALLATION

1. Set outer fairing in place and connect turn signal **J** and headlight **H** wire connectors.

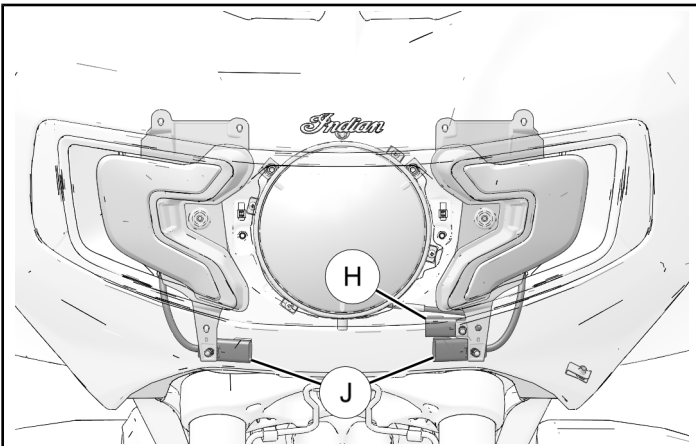

2. Press fairing into place and at top edge to engage locating pins.

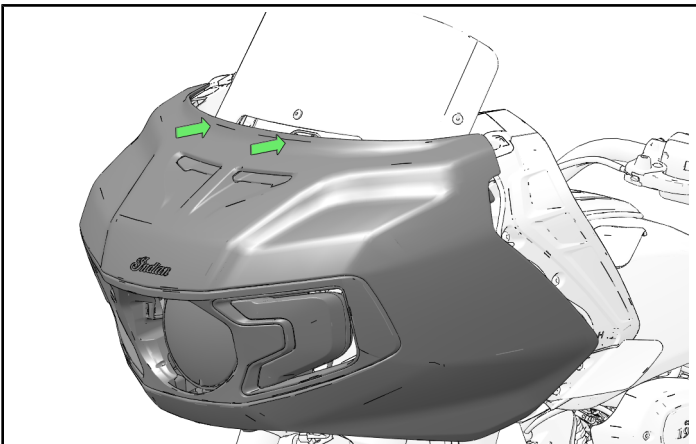

3. Loosely install one screw **G** into hole under edge of each side of fairing as shown. **DO NOT** torque fastener at this time.

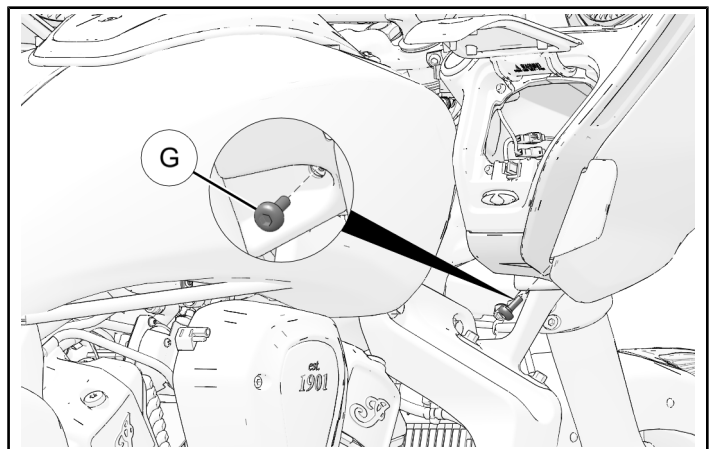
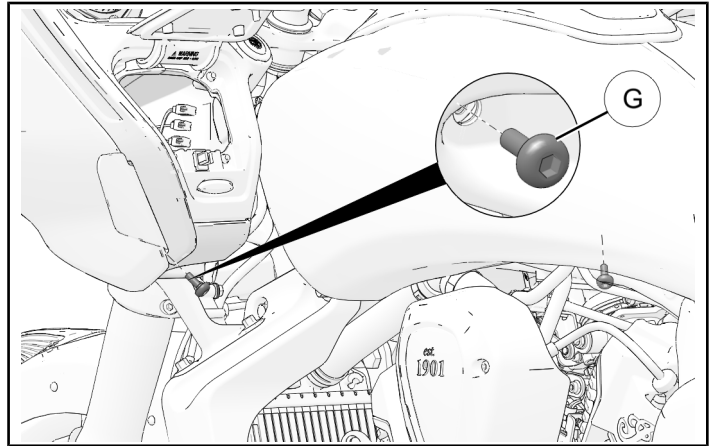

4. Loosely install two screws **F** into top outer corner of storage openings and two screws **F** into top center of speaker openings. **DO NOT** torque fasteners at this time.

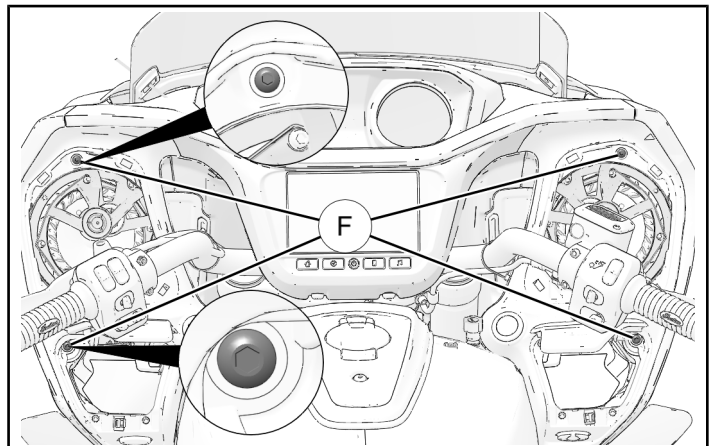

5. Loosely install three screws (E) around headlight bezel as shown.

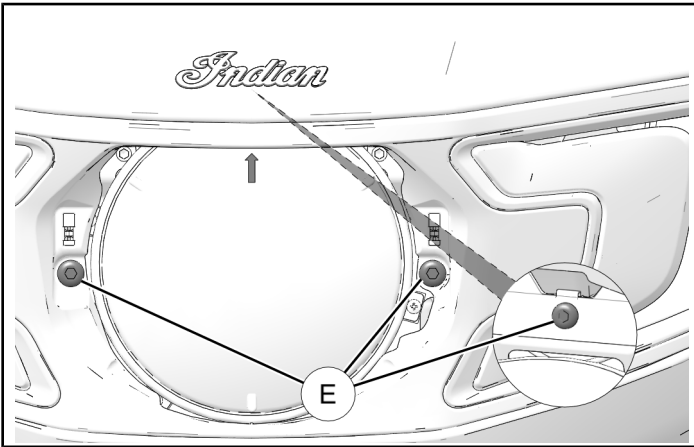

6. Torque all outer fairing screws to specification.

TORQUE

Outer Fairing Screws (E, F, G):
36 in-lbs (4 N·m)

7. Carefully reinstall headlight bezel (D) into outer fairing opening starting with bottom tab. Press down on bezel (or use non-marring tool as shown) to insert upper tabs without damaging finish.

TIP

Use Special Tool:
Non-marring Pry Tool, P/N 5456907 (or equivalent)

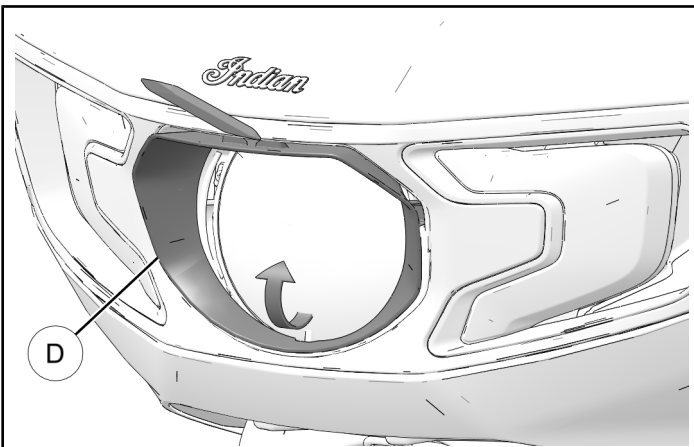

8. Reinstall fairing speaker grills (C).

9. Reinsert storage liners (B).

GENERAL

1. Apply decals (2) and (3) to sides of fender fin.

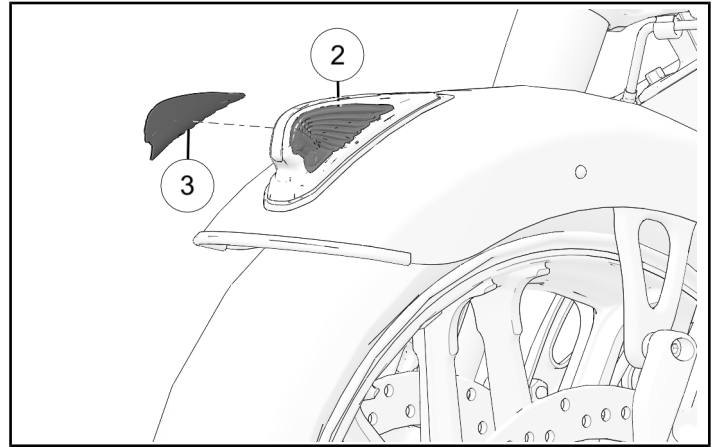

FEEDBACK FORM

A feedback form has been created for the installer to provide any comments, questions or concerns about the installation instructions. The form is viewable on mobile devices by scanning the QR code or by clicking [HERE](#) if viewing on a PC.

