

# FENDER TRIM KIT



**P/N 2880730 (Gloss Black)**

## APPLICATION

2014-2015 INDIAN MOTORCYCLES

## BEFORE YOU BEGIN

Read these instructions and check to be sure all parts and tools are accounted for in package. Please retain these installation instructions for future reference and parts ordering information.

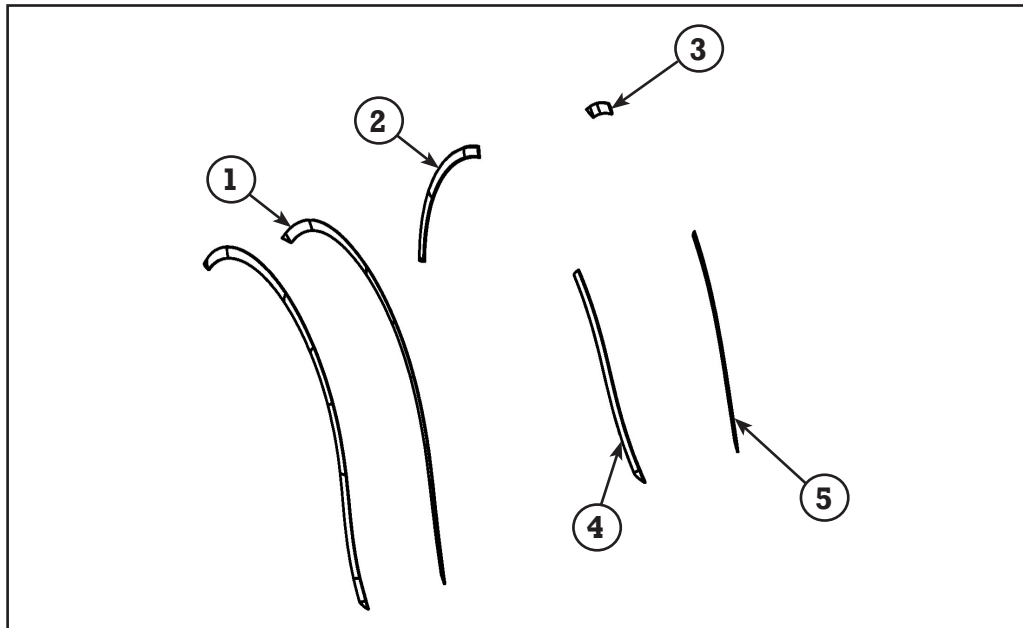

## KIT CONTENTS

Ref	Qty	Part Description	Part Number
1	2	Front Fender Trim	5451881
2	1	Rear Fender, LH Front Trim	5451882
3	1	Rear Fender, RH Front Trim	5451883
4	1	Rear Fender, LH Rear Trim	5451884
5	1	Rear Fender, RH Rear Trim	5451885
	1	Instructions	9925624

## TOOLS NEEDED

Socket Wrench

Torque Wrench

Hex Sockets

Denatured Alcohol

## APPROXIMATE ASSEMBLY TIME

60 mins.

## IMPORTANT

Your Indian FENDER TRIM KIT is exclusively designed for your vehicle. Please read the installation instructions thoroughly before beginning. Installation is easier if the vehicle is clean and free of debris. For your safety, and to ensure a satisfactory installation, perform all installation steps correctly in the sequence shown.

## INSTALLATION INSTRUCTIONS

**NOTE:** Place motorcycle on firm surface on side stand.

### Removal:

1. Remove two screws from RH strut cover (A), and retain screws (B).
2. Remove two screws from LH strut cover, and retain screws.
3. Remove all six pieces of stick on fender trim from the bike. There are two pieces on the front fender and four on the rear.
4. Ensure residue is removed from the fenders before installation of new trim.

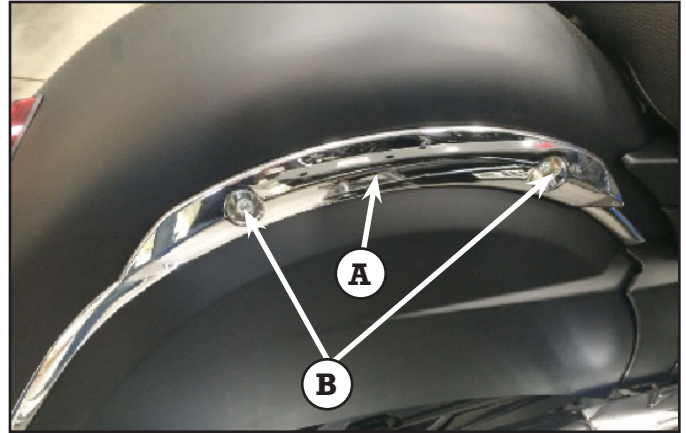

## IMPORTANT

### **Cleaning Matte Clear Coat Finishes:**

Matte finish products are prone to trapping dirt, oils and other contaminants. Always clean this type of finish with warm water and a mild dish-washing detergent. Use a soft sponge to gently rub the surface, and then rinse with clean warm water. For stubborn stains such as grease or oil, use a citrus-based cleaner. Spray the cleaner onto the area and rub gently with a soft sponge. Allow the cleaner to sit for a couple of minutes, and then rinse well with clean warm water. Repeat as needed.

**NOTE:** Never use a polishing/buffing wax or any sponge that has an abrasive surface when cleaning a matte finish. These products will buff the matte surface of the finish and result in a glossy finish. Never clean matte finishes with a pressure washer, as this will further imbed contaminants into the clear coat and may damage labels and decals.

### Installation:

1. Clean fender trim area with warm water and a mild dish-washing detergent before applying trim to remove any residue, dust, dirt, or grime.
2. Test-fit trim to the fender in all locations orientating the trim correctly. Repeat this step several times, ensuring that you will be able to correctly position the trim on the fender when the tape covering is removed.

**IMPORTANT:** The tape used to adhere the trim is aggressive. If you do not position it correctly, it will not be possible to remove or reposition without damaging the trim.

3. Remove the tape cover from the front fender trim. Run fender trim along crown trim line starting in the front for the front fender LH and RH trim pieces (1). Cut flush with the rear of the front fender.
4. Apply firm pressure along the trim during installation. Confirm all edges are adhered to the fender.

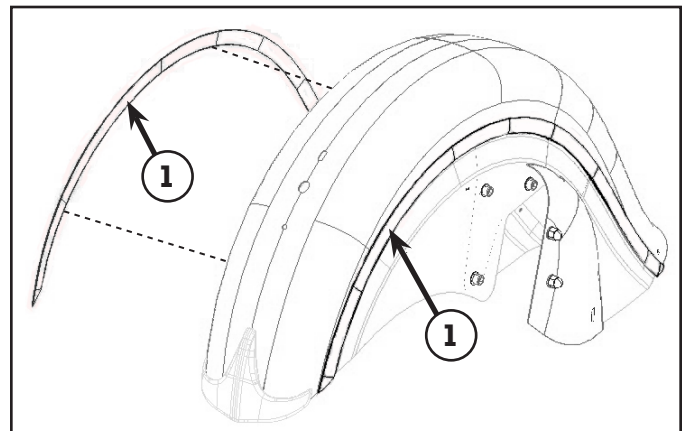

5. Remove the tape cover from the rear fender trim. Run fender trim along crown trim line starting in the rear for the rear fender RH rear trim (5) and rear fender LH rear trim (4).
6. Remove the tape cover from the rear fender trim. Run fender trim along crown trim line starting in the front for the rear fender RH front trim (3) and rear fender LH front trim (2).
7. Apply firm pressure along the trim during installation. Confirm that all edges are adhered to the fender.
8. Reinstall RH strut cover (A) using two screws (B).
9. Reinstall LH strut cover using two screws.
10. Torque all four screws to 84 in-lbs (9.5 Nm).

