

THUNDER STROKE® 111 STAGE 2 CAMSHAFT KIT

P/N 2881676



IMPORTANT

Due to the technical nature of this kit, Indian Motorcycles® requires installation be performed by a certified Indian Motorcycle® Technician.

NOTICE

Factory approved and certified accessories and calibrations are designed for maximum performance, while protecting the engine over a wide range of operating conditions. Use of aftermarket or unapproved accessories or calibrations will cause abnormal sensor or engine operation, error codes and risks damage to the engine. The Indian Motorcycle® Limited Warranty *excludes* damages or failures resulting from use of aftermarket or unapproved components, accessories, and calibrations.

APPLICATION

Indian Motorcycles® with 111 Thunder Stroke®

Verify accessory fitment at www.indianmotorcycle.com.

BEFORE YOU BEGIN

Read these instructions and check to be sure all parts and tools are accounted for. Please retain these installation instructions for future reference and parts ordering information.

REQUIRED SOLD SEPARATELY

Only parts for installation of the Indian Motorcycle® Thunder Stroke® 111 Stage 2 Camshaft Kit are included. Prior installation of the following additional kits is also required (sold separately):

- Stage 1 High Performance Air Cleaner Kit, PN 2881779-XXX or Thunder Stroke® High Flow Air Cleaner Kit, PN 2880654-XXX
- Stage 1 Muffler Kit, PN 2879529-XXX, 2879724-XXX, 2879768-XXX, or 2879769-XXX

NOTE

XXX = Indian® color code (For example: 266 = Black)

KIT CONTENTS

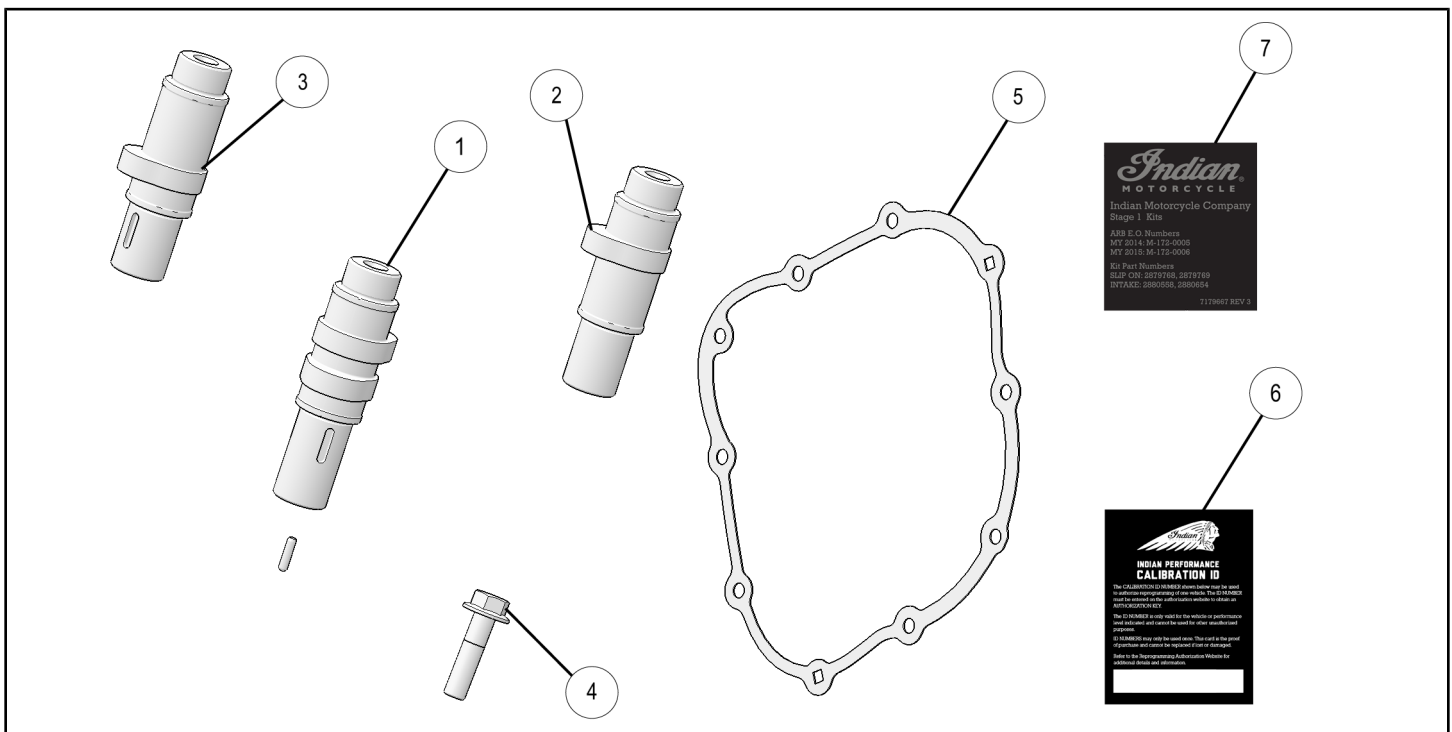

REF	QTY	PART DESCRIPTION	P/N AVAILABLE SEPARATELY
1	1	Camshaft, Stage 2, Intake	1205414
2	1	Camshaft, Stage 2, Exhaust, Front	1205415
3	1	Camshaft, Stage 2, Exhaust, Rear	1205416
4	4	Screw, Hex Flange Head, M10 X 1.5 X 40	7519763
5	1	Gasket, Camshaft Outer Cover	5813898
6	1	Calibration Card, 50 State	4014490
7	1	Label, IM, ACC	-
	1	Instructions	9926750

TOOLS REQUIRED

- Safety Glasses
- Digital Wrench™
- Drain Pan
- Hammer, Soft Face
- Platform Jack, Motorcycle
- Pliers, Side Cutting
- Pry Tool
- Screwdriver, Phillips
- Screwdriver, Slotted
- Socket Set, Hex Bit, Metric
- Socket Set, Metric
- Socket Set, Torx® Bit
- Torque Wrench
- Wrench Set, Metric
- Vehicle Lift/Support Equipment
- **Special Service Tool:**
Camshaft Holding Tool PN PF-52544 and PF-524544 **or** PF-51455-A (Combination Kit)

CONSUMABLES REQUIRED

- Grease, Polaris All Season (or equivalent)

IMPORTANT

Your Indian Motorcycle® Thunder Stroke® 111 Stage 2 Camshaft Kit is exclusively designed for your vehicle. Please read the installation instructions thoroughly before beginning. Installation is easier if the vehicle is clean and free of debris. For your safety, and to ensure a satisfactory installation, perform all installation steps correctly in the sequence shown.

ASSEMBLY TIME

Approximately 1.0 hours

NOTE

Additional time may be required to accommodate other accessories.

INSTALLATION INSTRUCTIONS

IMPORTANT

Protect all finished surfaces during these operations.

NOTE

Take careful notes of wire routing and cable tie locations during disassembly to ensure proper reinstallation.

Special care should be taken on higher mileage bikes during disassembly. Especially when removing fasteners threaded into engine block and cylinder heads (For example: Exhaust manifold bolts, Primary cover bolts, etc.) Thread repair kit may be necessary if threads become damaged.

VEHICLE PREPARATION

GENERAL

1. Turn key or ignition switch to “OFF” position and remove key. If equipped with keyless fob, remove fob from proximity of vehicle.
2. Park motorcycle securely on a lift table with front tire clamped securely in a wheel vise.
3. Drain engine oil.
4. Remove and retain upper and lower side covers, saddlebags, and seat as per owner’s manual. Disconnect battery as per owner’s manual.

RIGHT FLOORBOARD REMOVAL

1. Remove cotter pin **A** and washer **B** from brake master cylinder pushrod.

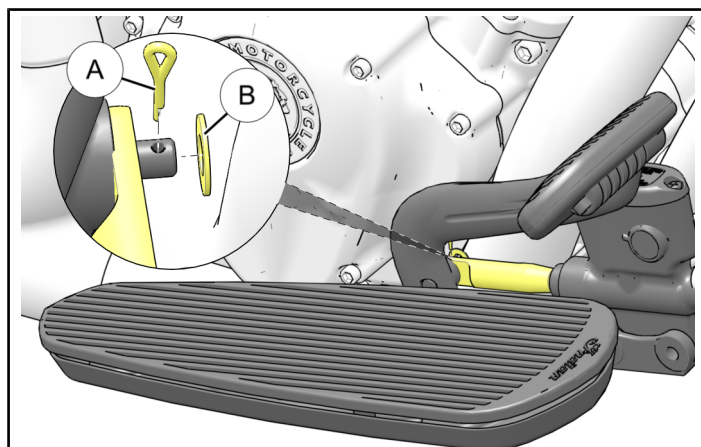

- Remove and retain two screws (C) from brake master cylinder (D), disengage pushrod from brake pedal assembly, and remove brake master cylinder (D) from RH floorboard assembly and move out of the way.

CAUTION

Do not bend or kink flexible brake line during floorboard removal. Master cylinder assembly should be kept in an upright position and properly supported at all times.

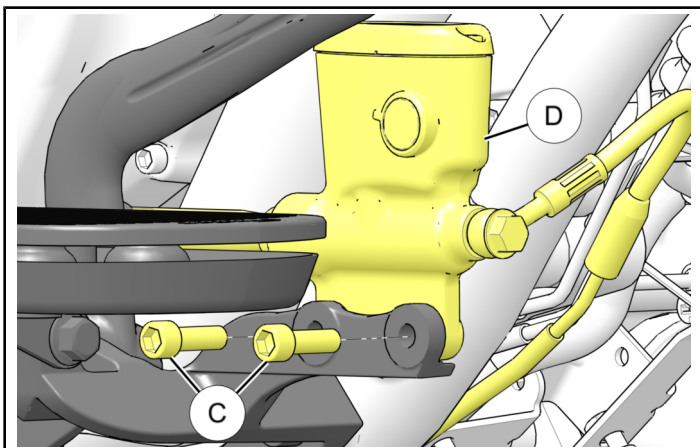

- Remove and retain two bolts (E) and remove RH floorboard assembly (F) from frame.

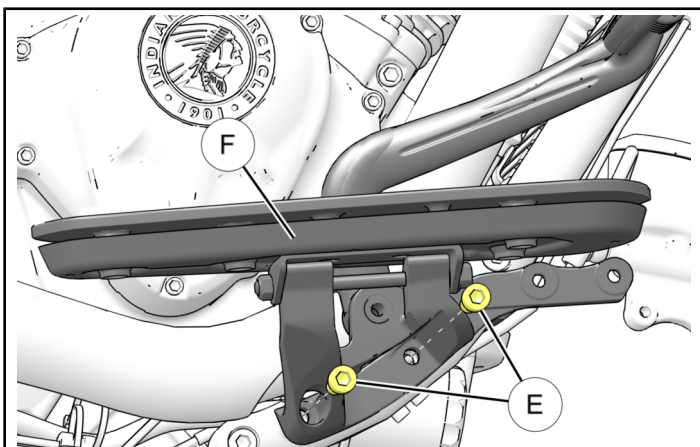

ACCESSORY INSTALLATION

REMOVE AND INSTALL CAMSHAFTS

CAM CHAIN, GUIDE AND TENSIONER REMOVAL

- Remove and retain ten fasteners (A) and (B), make note of different sizes and locations. Remove cam chain cover (C) and gasket.

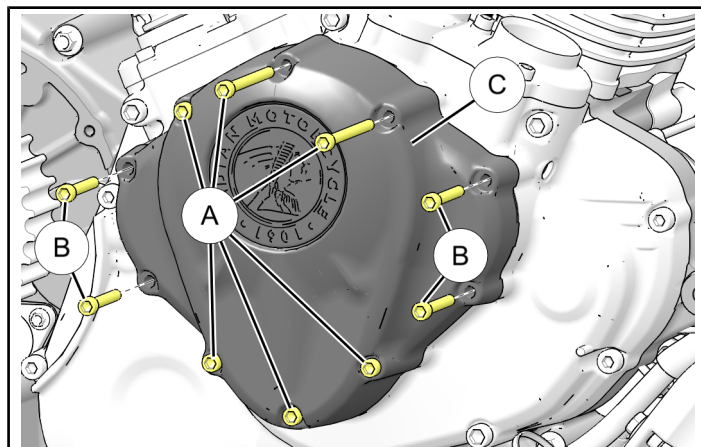

- Ensure indents on gear faces align with each other as shown. If they do not, repeat crankshaft locking procedure and align them.

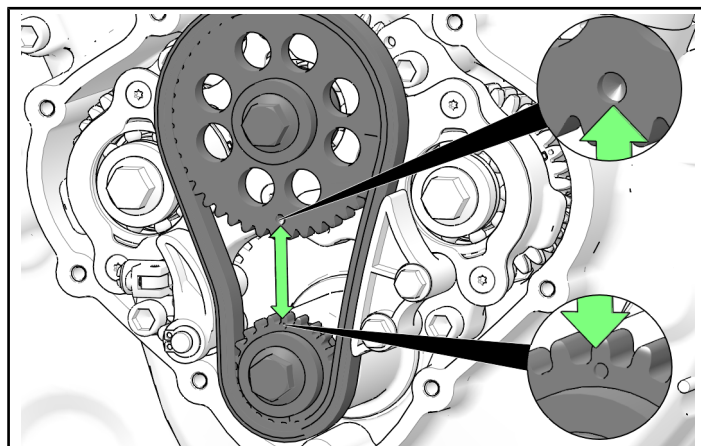

- Loosen, but **DO NOT REMOVE** four screws (D).

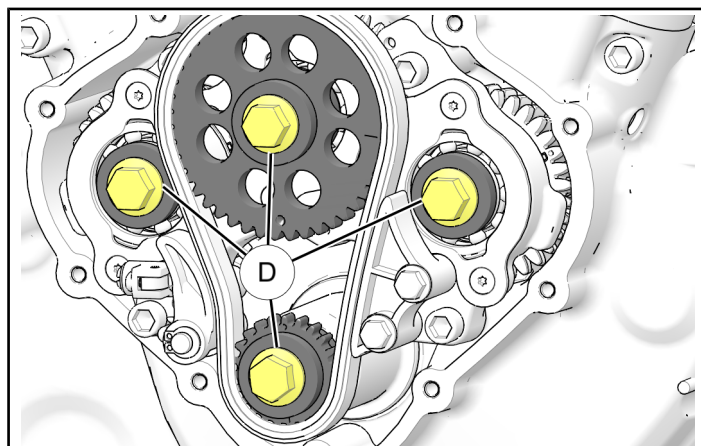

4. Remove and retain chain tensioner fastener ⑤ and chain tensioner ⑥.

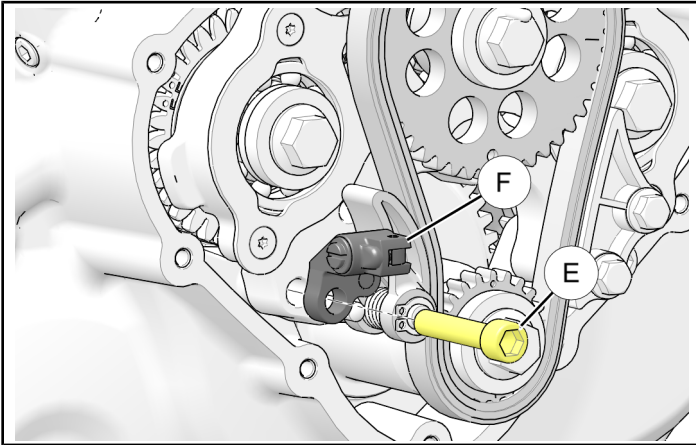

5. Remove and retain external snap ring ⑦ and chain tensioner arm and spring assembly ⑧.

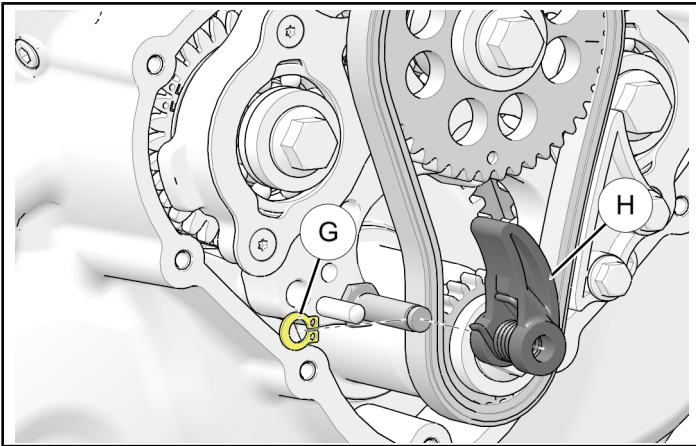

6. Remove and retain two fasteners ⑩ and Camshaft Chain Guide ⑪.

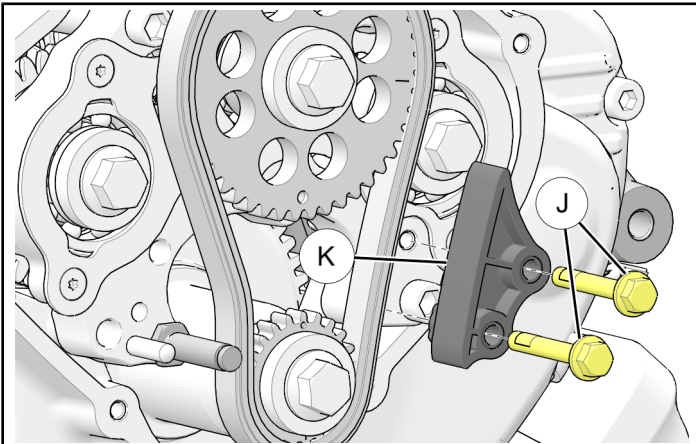

7. Remove and retain screws ④ and washers ③ from crankshaft and camshaft. Pull camshaft sprocket ①, crankshaft sprocket ② and cam chain ④ off as an assembly and set aside. Collect woodruff key ⑤ from crankshaft and set aside.

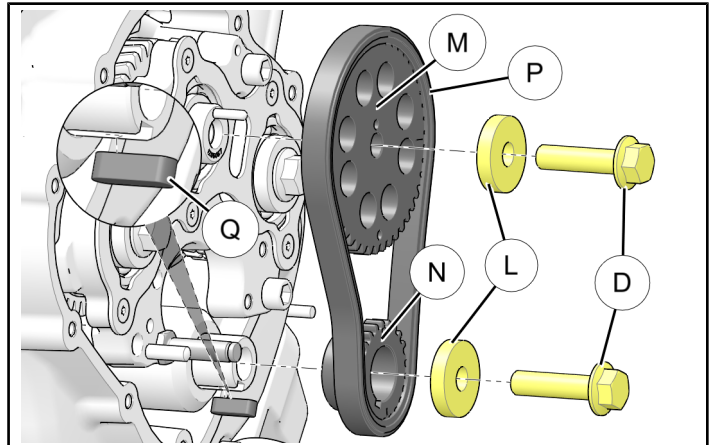

REMOVE AND INSTALL CAMSHAFTS

IMPORTANT

Camshaft removal with cylinder heads torqued in place requires Special Tool: **PF-51455-A**

1. Remove and install camshafts as per service manual procedure "**CAMSHAFT SERVICE - IN BIKE**"
2. Install new camshafts ①, ②, and ③ with new screws ④ as per service manual procedure.

TORQUE

Camshaft Screws ④: **52 ft. lbs. (70 Nm)**
Camshaft Carrier Fasteners: **15 ft. lbs. (20 Nm)**

CAM CHAIN INSTALLATION

CAUTION

Thunder Stroke is an INTERFERENCE ENGINE. If camshafts and crankshaft must be turned independently of each other to set valve timing, camshafts must be set to TDC prior to rotating crankshaft. Failure to do this may cause pistons to contact valve resulting in engine damage.

1. Verify camshafts are set to TDC.
 - a. Camshaft timing marks **A** and **B** should be aligned as shown. Camshaft sprocket alignment dowel **C** should be at 12 o'clock as shown.

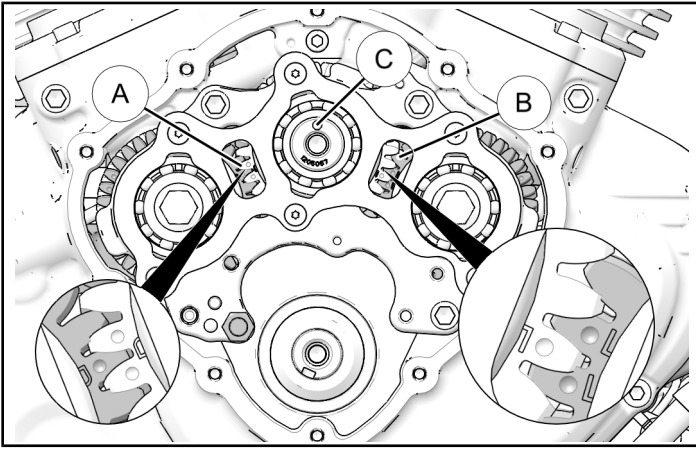

2. Assemble timing chain onto camshaft and crankshaft sprockets.
 - a. Align timing marks **D** as shown.
 - b. Position chain so dark chain links line up with sprocket hashmarks as shown.

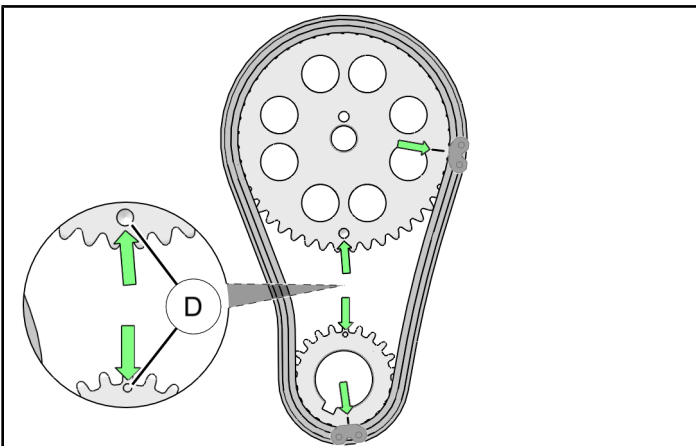

3. Slide chain and sprocket assembly onto crankshaft and center camshaft.

4. Verify crankshaft woodruff key **E** is in place and timing marks are aligned.

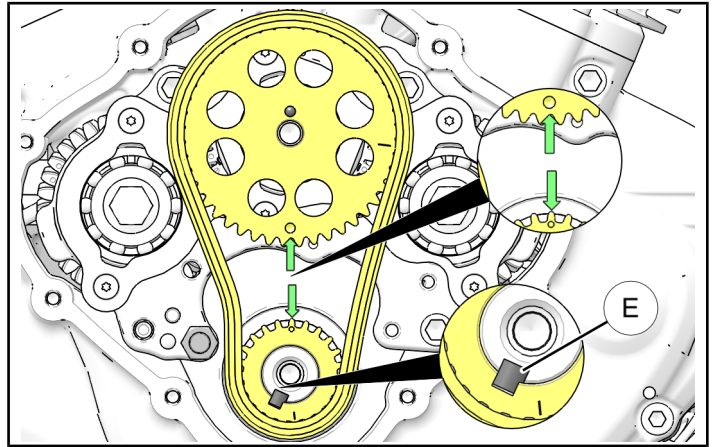

5. Install retained crankshaft and camshaft sprocket fasteners and retained washer and torque to specification.

TORQUE

Sprocket Screws: **52 ft. lbs. (70 Nm)**

6. Install retained cam chain guide and torque fasteners to specification.

TORQUE

Cam Chain Guide Screws **1**: **71 in. lbs. (8 Nm)**

7. Install retained cam chain tensioner and tensioner arm assemblies. Torque to specification.

TORQUE

Cam Chain Tensioner Arm Screw **E**: **15 ft. lbs. (20 Nm)**

- Clean gasket mating surfaces and install retained cam chain cover with new gasket ⑤. Torque screws to specification using the following torque sequence.

TORQUE

Cam Chain Cover Screw ①: **10 ft. lbs. (13 Nm)**

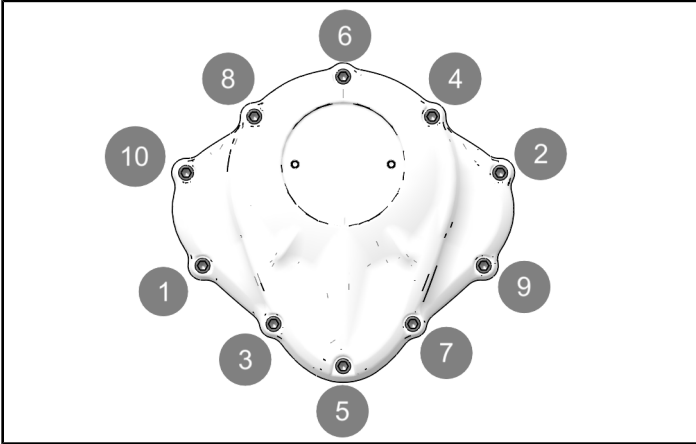

VEHICLE REASSEMBLY

RIGHT FLOORBOARD INSTALLATION

- Hold floorboard assembly ⑥ in place and secure with two retained bolts ④. Torque screws to specification.

TORQUE

Floorboard assembly screws ④: **35 ft. lbs. (47 Nm)**

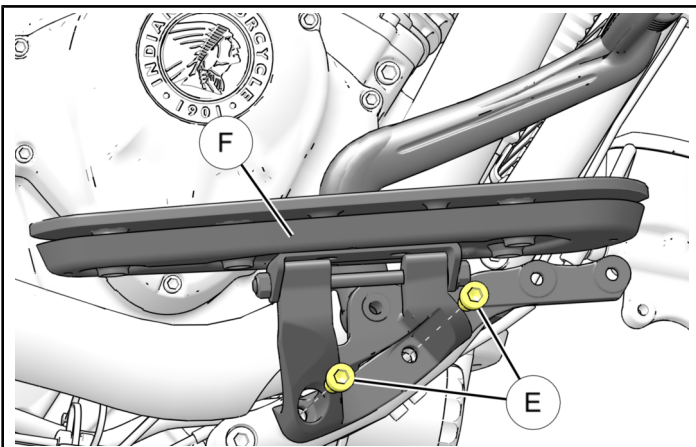

- Lower brake master cylinder ① in place, engaging pushrod onto brake pedal assembly and secure with two retained screws ③. Torque screws to specification.

CAUTION

Do not bend or kink flexible brake line during floorboard removal. Master cylinder assembly should be kept in an upright position and properly supported at all times.

TORQUE

Brake Master Cylinder Mounting Screws ③: **18 ft. lbs. (24 Nm)**

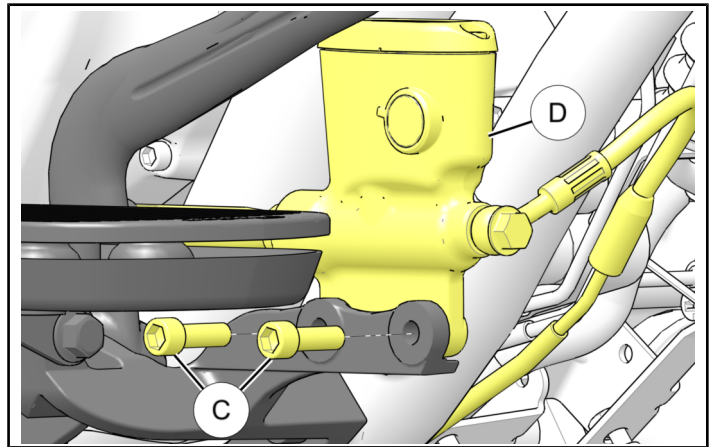

- Apply a thin coat of grease to pushrod pivot pin and install retained washer ② and cotter pin ① onto brake master cylinder pushrod.

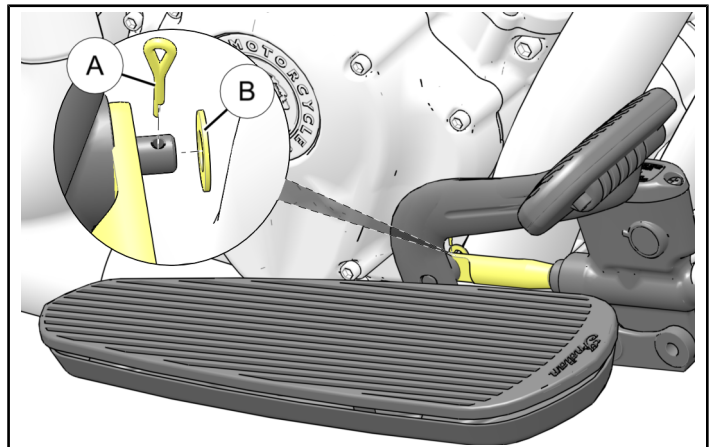

- Test foot brake and verify pedal feels firm and no air has entered hydraulic circuit. Bleed brakes if necessary.

GENERAL

1. Fill and check oil level as per owner's manual.
2. Reconnect battery as per owner's manual.
3. Reinstall upper and lower side covers, saddlebags and seat as per owner's manual.

APPLY LABEL AND UPDATE ECM

1. Install aftermarket exemption label ⑦ required by California Air Resource Board (CARB). To determine if motorcycle is a 50-State model, look for a California EVAP label ① on left hand down-tube frame ②. If label is on frame, apply new CARB exemption label ⑦ on left hand down-tube frame underneath EVAP label as shown.

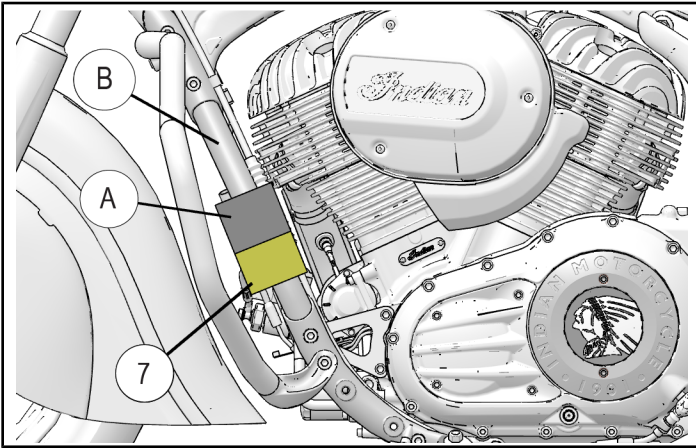

IMPORTANT

Product information label is required to aid in passing California Smog Check Program.

FEEDBACK FORM

A feedback form has been created for the installer to provide any comments, questions or concerns about the installation instructions. The form is viewable on mobile devices by scanning the QR code or by clicking [HERE](#) if viewing on a PC.

FEEDBACK FORM



2. Update ECM with new calibration software using included Calibration Card ⑥.

IMPORTANT

This step must be completed by an Authorized Indian Dealer. Do not operate vehicle until re-calibration of vehicle is complete.