

TRUNK INSTALLATION KIT



P/N 2884007

APPLICATION

All 2019 and newer Springfield® and Chieftain® models
Verify accessory's fitment at www.indianmotorcycle.com

BEFORE YOU BEGIN

Read these instructions and check to be sure all parts and tools are accounted for. Please retain these installation instructions for future reference and parts ordering information.

REQUIRED SOLD SEPARATELY

Only parts for the Indian Motorcycle® Trunk Installation Kit are included. For complete installation the following additional kits are also required (sold separately):

- *Trunk Base Kit*, P/N 2884048-XXX
- *Trunk Kit*, P/N 2884046-XXX

NOTE

XXX = Indian Motorcycle® color code (For example: 266 = Black)

KIT CONTENTS

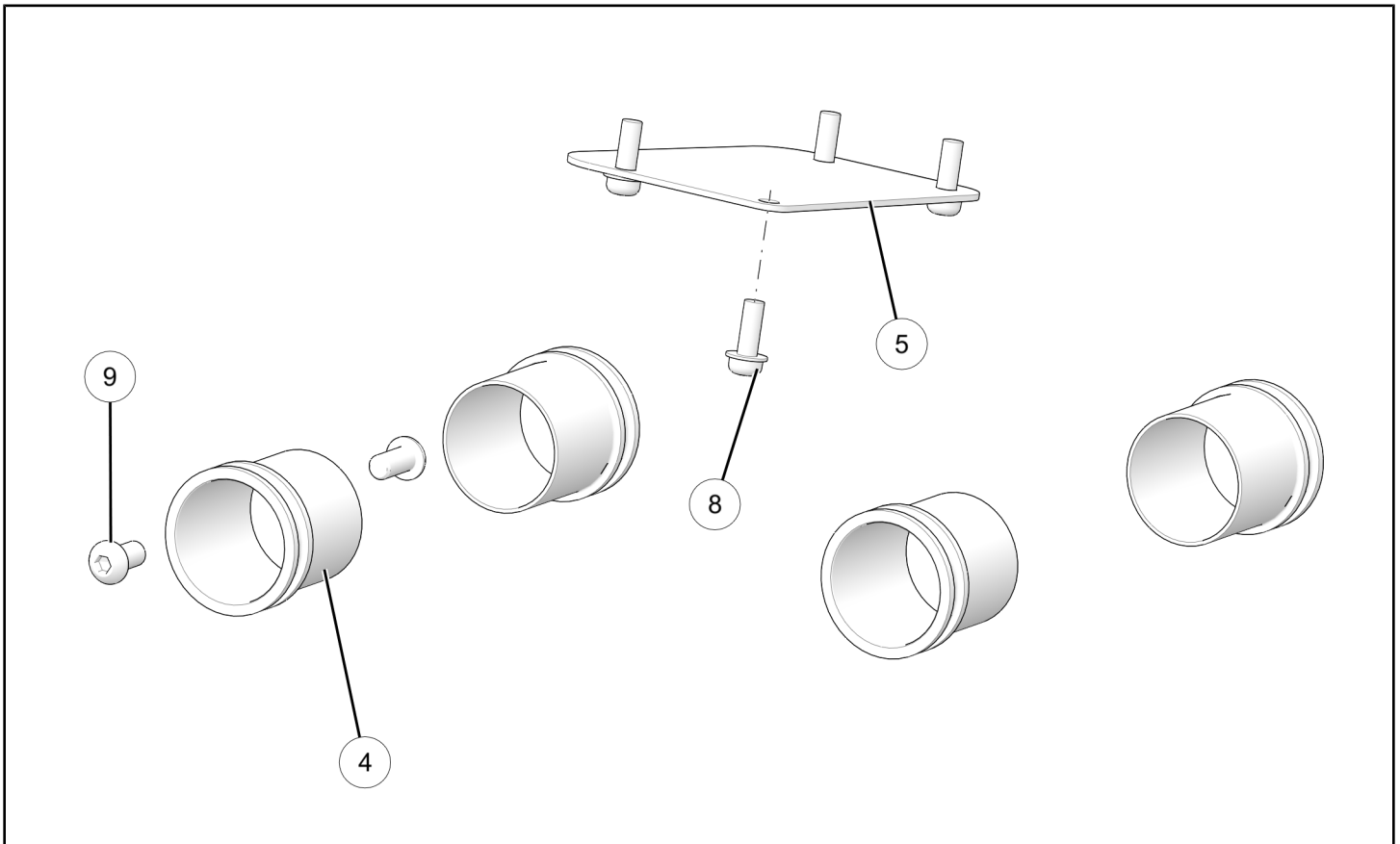

REF	QTY	PART DESCRIPTION	P/N AVAILABLE SEPARATELY
1	1	Harness–Trunk, Chieftain® Seat (see <i>Harness Detail</i> section)	2414487
2	1	Harness–Trunk HP Audio (see <i>Harness Detail</i> section)	2414638
3	1	Harness–Under Seat, H/C (see <i>Harness Detail</i> section)	2414641
4	4	Bushing–Spool, Trunk	5455069
5	1	PL–Wire Cover, Seat, Touring, Heated	5814094
6	2	Cable Tie (not shown)	7080138
7	3	Cable Tie–Release, 7 3/4 in. (not shown)	7082000
8	4	Screw–Washer Pan Head, 10-16, HiLo	7518641
9	2	Screw–Hex Button Head, M6 x 1.0 x 12	7519000

HARNESS DETAIL

SEAT HARNESS ① P/N 2414487



REF	PART DESCRIPTION	PIN QTY/ GENDER	CONNECTS TO
1A	Connector, Trunk	16 pin Female	Harness, Trunk
1B	Connector, Chassis	16 pin Male	Harness, Chassis

TRUNK HARNESS ②
P/N 2414638

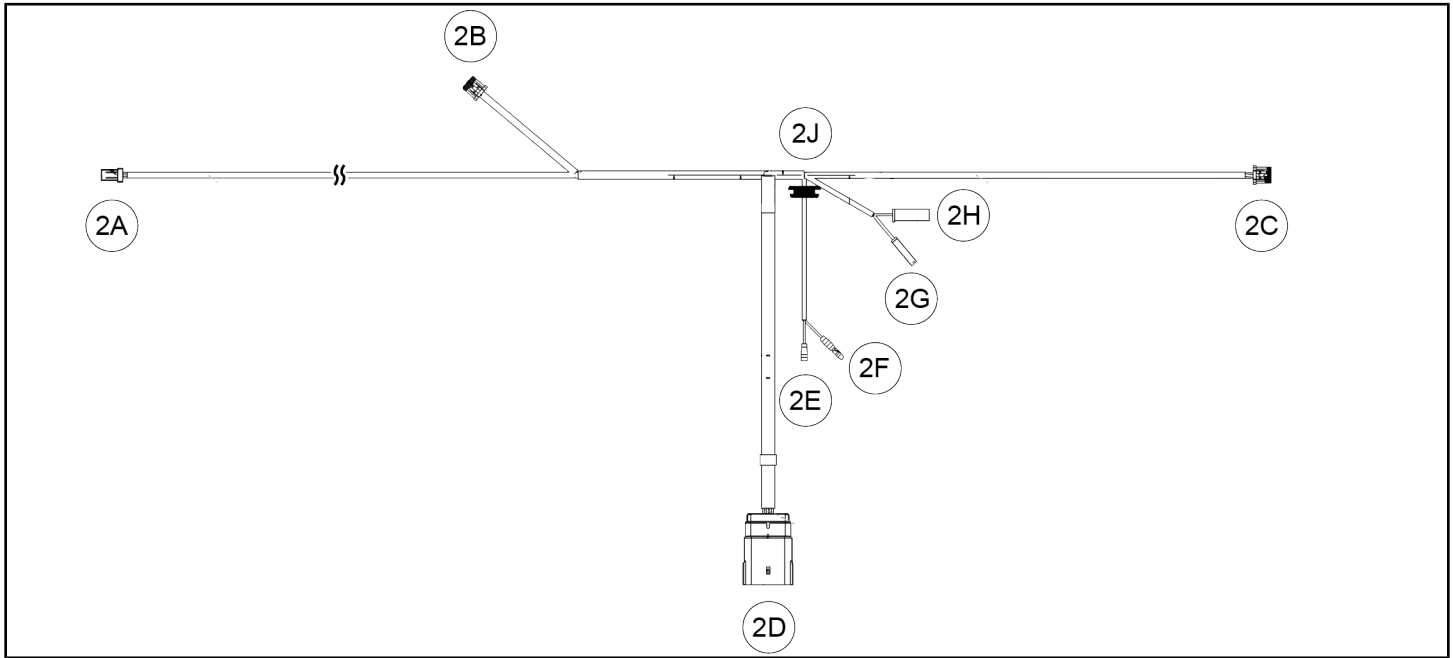

REF	PART DESCRIPTION	PIN QTY/ GENDER	CONNECTS TO
2A	Connector, Taillight	16 pin Female	Taillight
2B	Connector, Trunk Speaker, LH	16 pin Male	Trunk Speaker, LH
2C	Connector, Trunk Speaker, RH	4 pin Female	Trunk Speaker, RH
2D	Connector, Chassis Harness	16 pin Male	Chassis Harness
2E	Connector, Bullet, Lock A	Female	Lock A, Trunk Unlock
2F	Connector, Bullet, Lock B	Male	Lock A, Trunk Lock
*2G	Connector, Accessory Port, Positive	N/A	Accessory Port, Positive
*2H	Connector, Accessory Port, Ground	N/A	Accessory Port, Ground
2J	Grommet-Speaker, Volume	N/A	Trunk

SEAT HARNESS ③
P/N 2414641

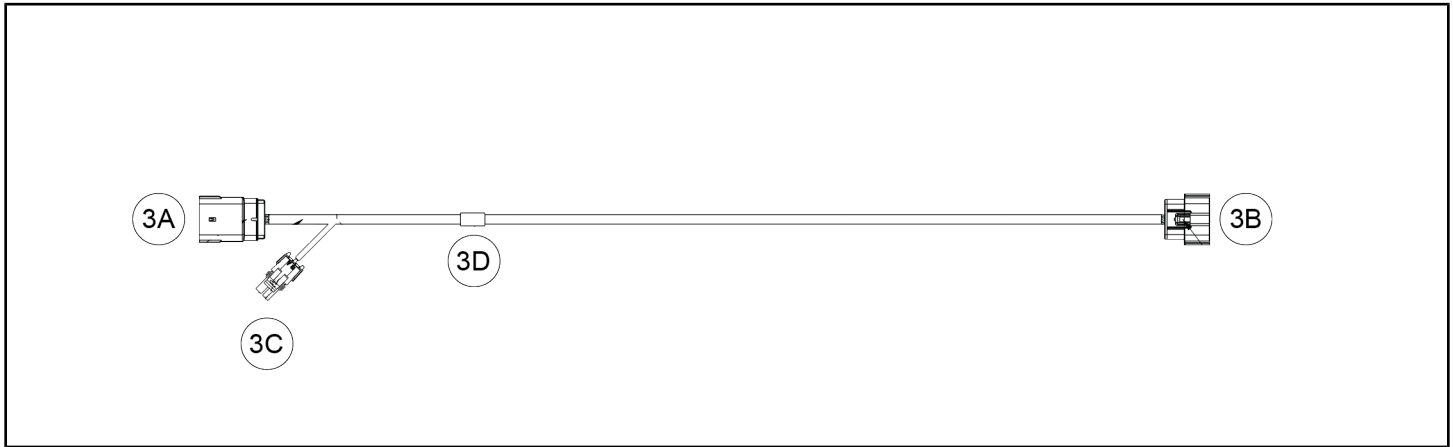

REF	PART DESCRIPTION	PIN QTY/ GENDER	CONNECTS TO
3A	Connector, Chassis Harness	16 pin Male	Harness, Chassis
3B	Connector, Trunk	16 pin Female	Trunk
3C	Connector, Trunk	2 pin Female	Harness, Heated Seat
3D	Tape, White	N/A	Identifies installation location for cable tie ⑦

TOOLS REQUIRED

- Safety Glasses
- Socket Set, Hex Bit, Metric
- Socket Set, Metric
- Torque Wrench

IMPORTANT

Your Indian Motorcycle® Trunk Installation Kit is exclusively designed for your vehicle. Please read the installation instructions thoroughly before beginning. Installation is easier if the vehicle is clean and free of debris. For your safety, and to ensure a satisfactory installation, perform all installation steps correctly in the sequence shown.

INSTALLATION INSTRUCTIONS

VEHICLE PREPARATION

GENERAL

1. Ensure motorcycle is parked on a flat surface, kickstand is fully extended, and vehicle is stable prior to installation.
2. Remove keyless fob from proximity of motorcycle.
3. Remove hard saddlebags as per owner's manual.

ACCESSORY INSTALLATION

SPOOL BUSHING INSTALLATION

1. For models without spool bushings, remove and retain four special screws (A) and stock spools (B).

TIP

Strut cover (if equipped) may need to be loosened to remove spools. Reinstall each strut cover with two screws.

Torque strut cover screws: **84 in. lbs. (9.5 Nm)**

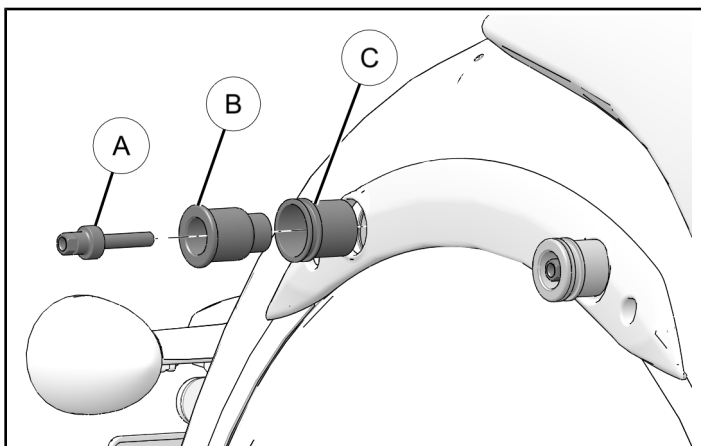

2. Slide one bushing (5) over one spool (B) and install with one retained special screw (A). Repeat this step for three additional spool/bushing assemblies. Torque screws to specification.

TORQUE

Special Screws (A):
32 ft-lbs (43 N·m)

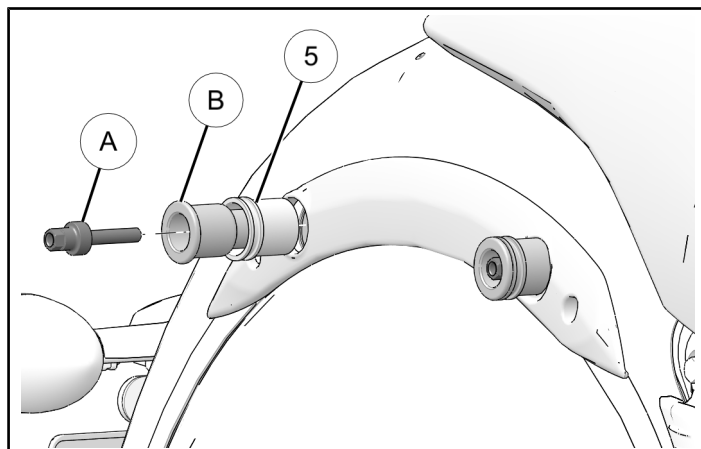

SPEAKER ENCLOSURE REMOVAL

1. Place trunk on clean and flat surface, open trunk lid.
2. Remove and retain trunk liners.
3. Remove and retain three screws (A), holding speaker enclosure to trunk structure.

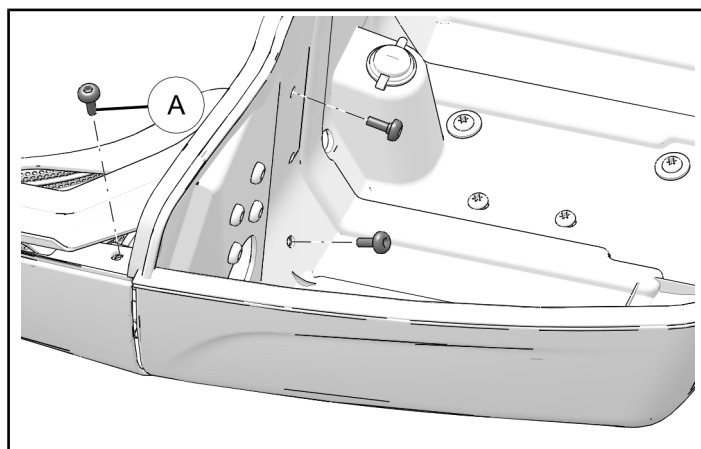

4. Close trunk lid and pull speaker enclosure away from trunk structure.

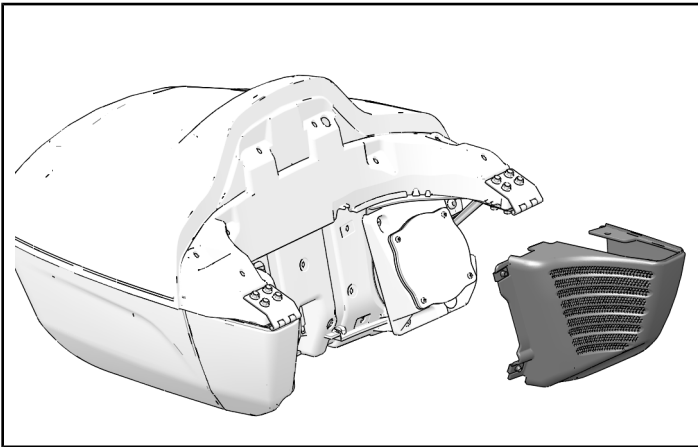

5. Repeat this section for opposite speaker cover.

TRUNK HARNESS ② ROUTING

NOTE

This section references specific components of Trunk Harness ② P/N 2414638. See *Harness Detail* section for details.

1. Remove and retain two screws (A) from each speaker housing.

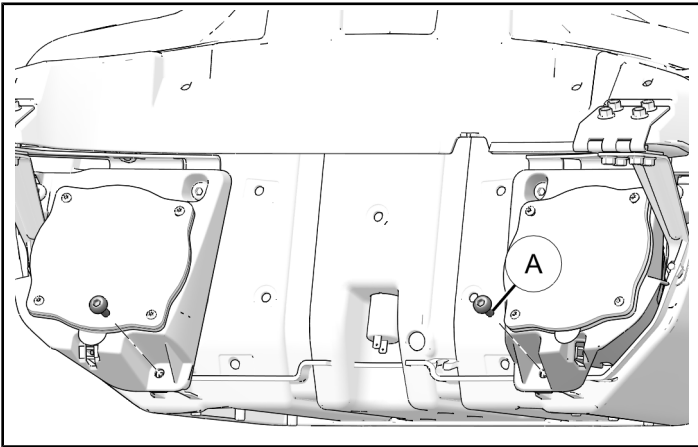

2. Flex LH speaker housing upward to route trunk harness connectors 2A and 2B.

- Route trunk harness connector 2A upwards along speaker housing and clip to housing.
- Route trunk harness connector 2B through hole into trunk compartment.

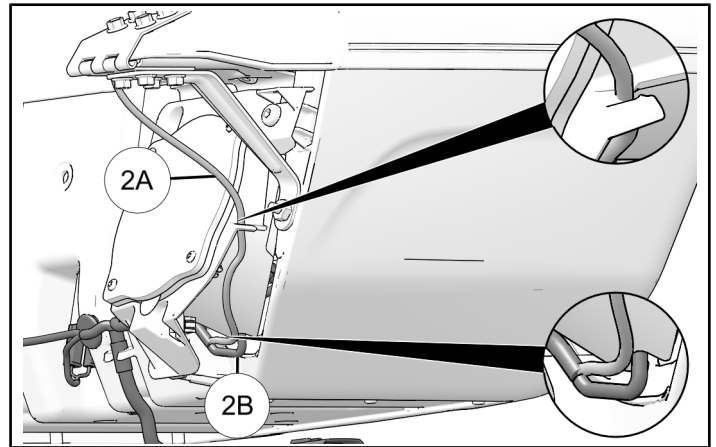

3. Secure center of trunk harness ② to built-in clip at taped location.
 - Route lock connectors 2E and 2F into trunk compartment. Seal hole with grommet 2J.
 - Join positive connector 2G (small connector) to power supply.
 - Join ground connector 2H (large connector) to power supply.

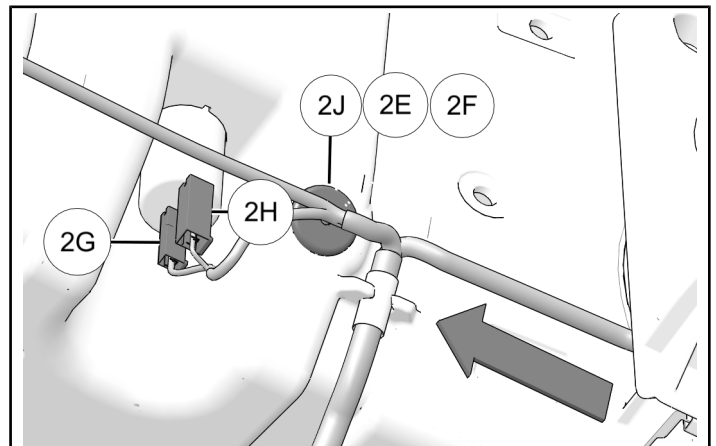

4. Flex RH speaker housing upward to route trunk harness connectors **2C** into trunk compartment.

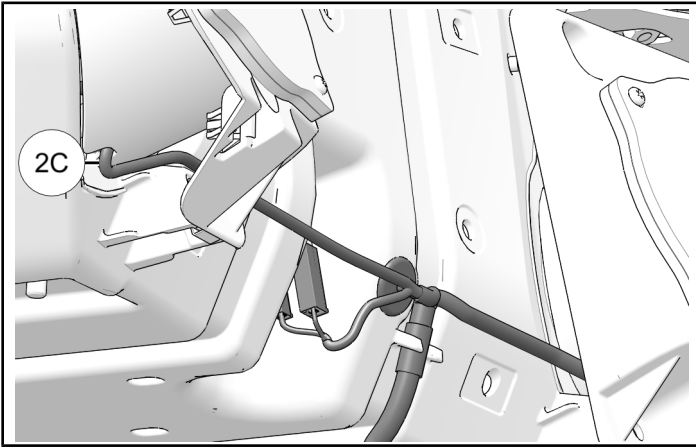

5. Continue to route trunk harness connector **2A** up along trunk back rest and join to taillight connector. Ensure harness is firmly secure within clips.

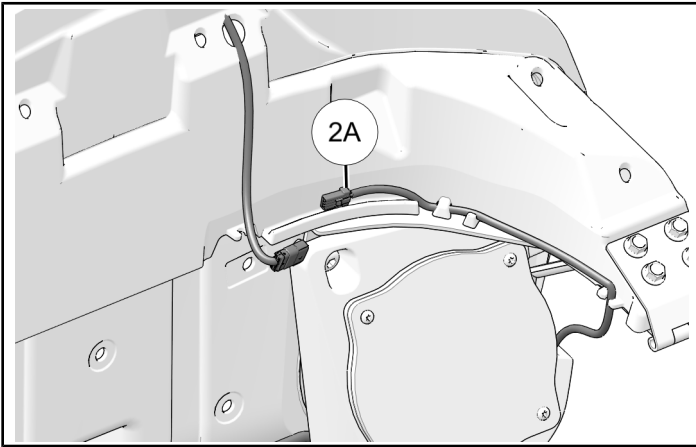

6. Reinstall speaker housings with two screws **A**. Torque screws to specification.

TORQUE

Speaker Housing Screws **A**:
36 in-lbs (4 N·m)

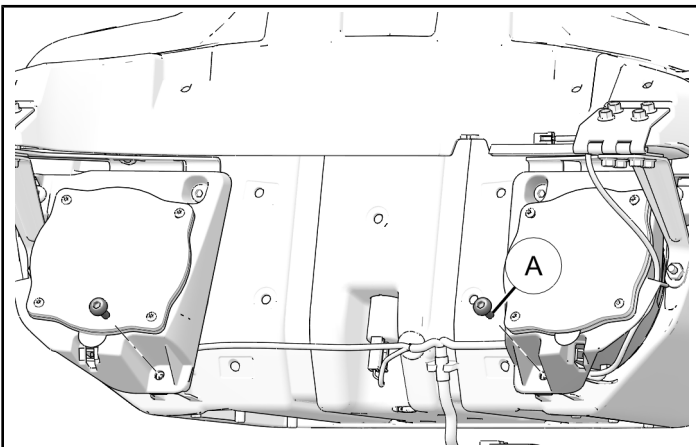

TRUNK AUDIO INSTALLATION

1. Follow installation instructions for selected audio kit (sold separately).
2. Reinstall speaker enclosures with three retained screws **A** per enclosure. Torque screws to specification.

TORQUE

Speaker enclosure screws **A**:
36 in-lbs (4 N·m)

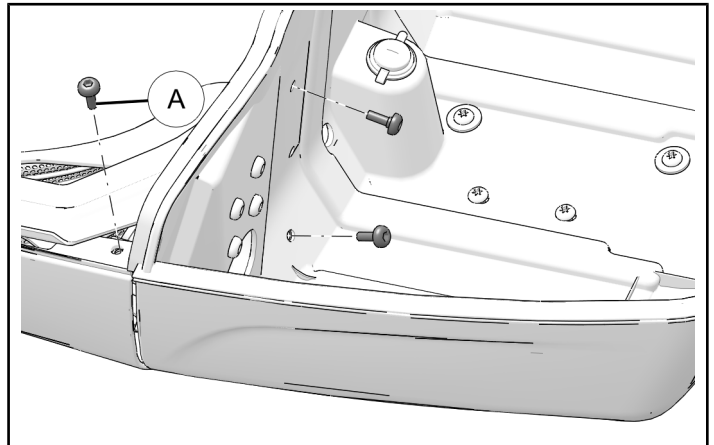

TRUNK BASE AND TRUNK INSTALLATION

1. Install *Trunk Frame Kit* P/N 2884048-XXX onto new spools.
 - a. Hook front of trunk frame onto front spools before lowering frame-rear onto rear spools.

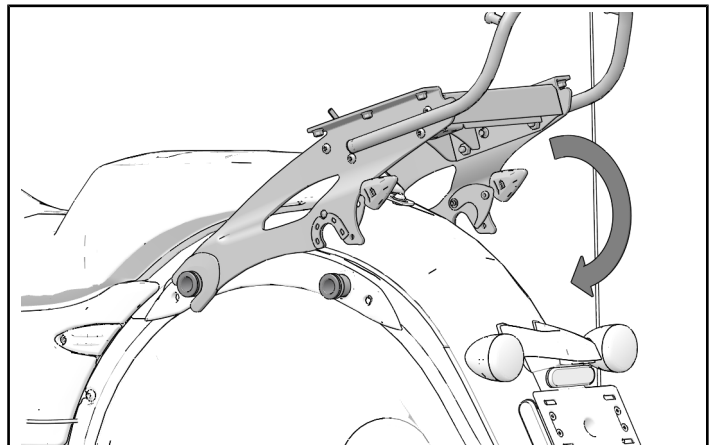

- b. Close latches onto spools to lock frame into place.

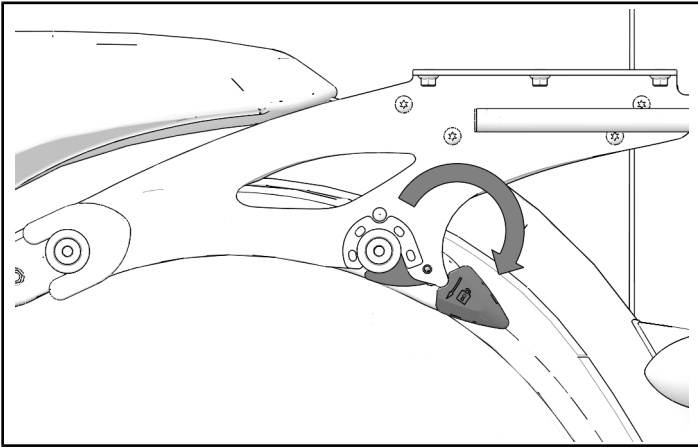

2. Proceed with installing *Quick Release Trunk Kit* P/N 2884046-XXX, as per installation instructions.

TRUNK FITMENT

NOTE

Optional, for models with rear fender closeouts.

1. Remove trunk from vehicle and carefully set aside as to not damage painted finish.
2. For improved trunk fitment, RH lower closeout can be removed. Remove two screws (A) to remove RH lower closeout.

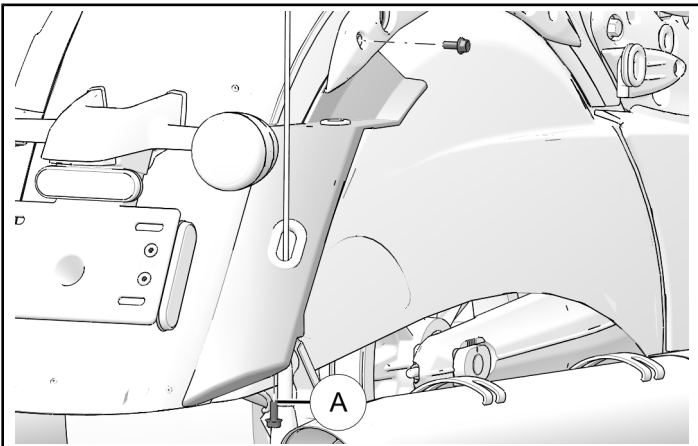

3. Reinstall one screw (A) to strut cover (if equipped) or fender. Torque screw to specification.

TORQUE

Strut Cover Screw (A):
84 in-lbs (9.5 N·m)

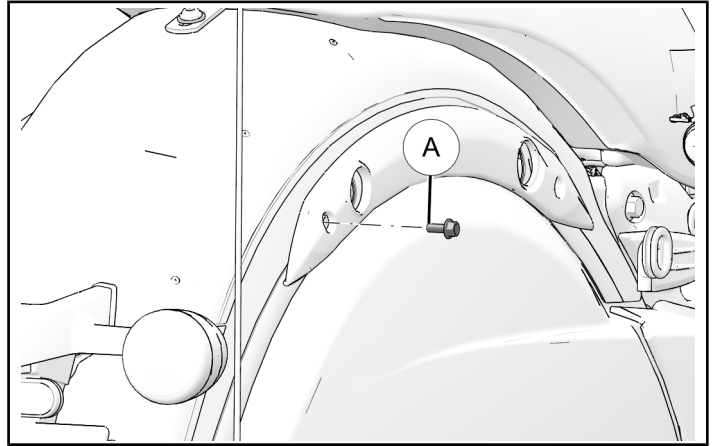

4. Reinstall trunk/trunk base assembly to motorcycle.

TOURING SEAT HARNESS (3) ROUTING (IF APPLICABLE)

NOTE

This section references specific components of Touring Seat Harness (3) P/N 2414641. See *Harness Detail* section for details.

NOTE

This section references components on *Touring Heated Seat* P/N 2882563-XX (sold separately).

1. Remove seat as per owner's manual.
2. Set seat upside down on clean surface.
3. Install harness to underside of seat.

- Attach touring seat harness ③ to clips in built-in to seat base.
- Attach to seat at taped location 3D with one cable tie ⑥.

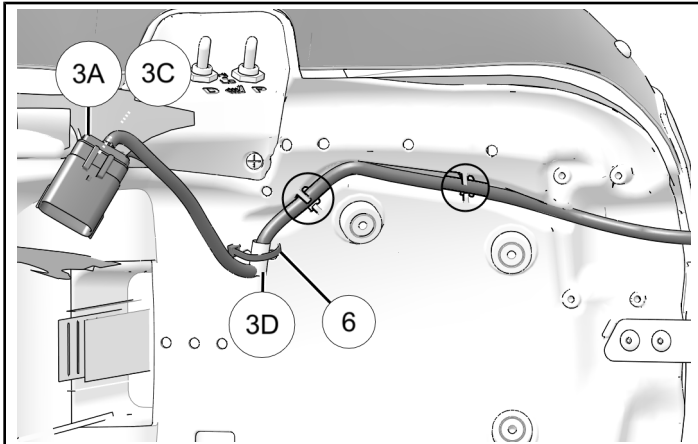

4. Install wire cover ⑤ onto seat base with four screws ⑧. Torque screws to specification.

TORQUE

Wire Cover Screws ⑧:
14 in-lbs (1.5 N·m)

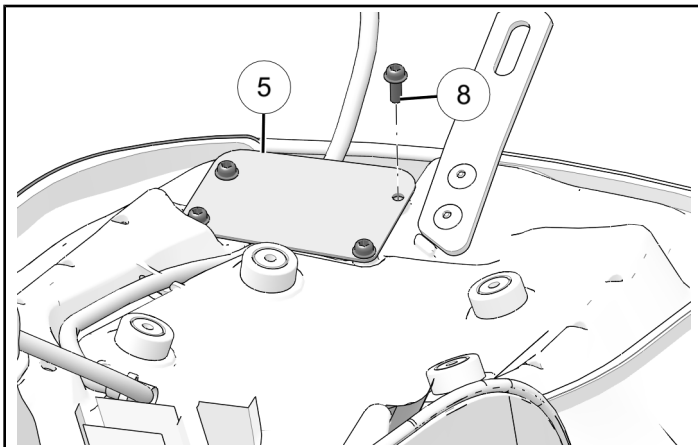

5. Place seat back onto motorcycle and before installing join harness connectors 3A and 3C to their corresponding chassis harness connectors. Install seat as per owner's manual.

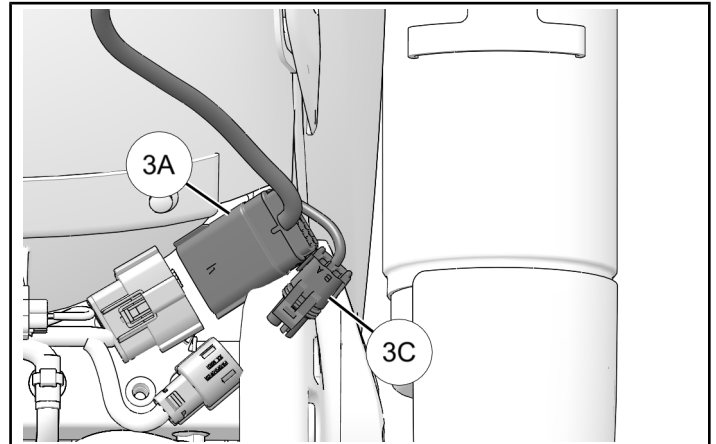

6. Join seat harness connector 3B to trunk harness connector 2D. Once joined, place connection atop bracket.

NOTE

Secure seat harness to trunk frame with cable tie ⑥.

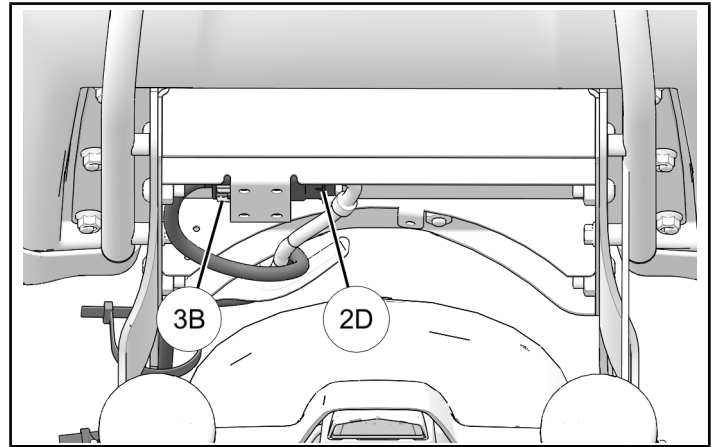

STOCK SEAT HARNESS ① ROUTING (IF APPLICABLE)

NOTE

This section references components on *Stock Seat Harness ①* P/N 2414487

1. Remove seat as per owner's manual.

2. Connect connector **1B** to chassis harness and begin to route harness under LH side cover.

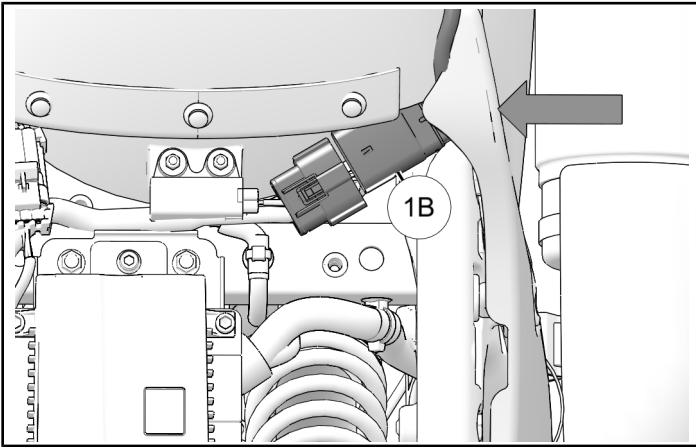

3. Secure harness to trunk base with two cable ties **⑦**.

NOTE

Ensure cable ties do not come into contact with painted surfaces during this step.

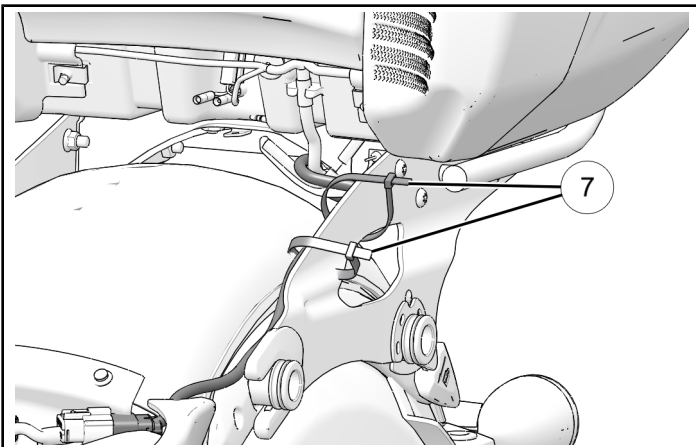

4. Join seat harness connector **1A** to trunk harness connector **2D**. Once joined, place connection atop bracket.

NOTE

Secure seat harness to trunk frame with cable tie **⑥**.

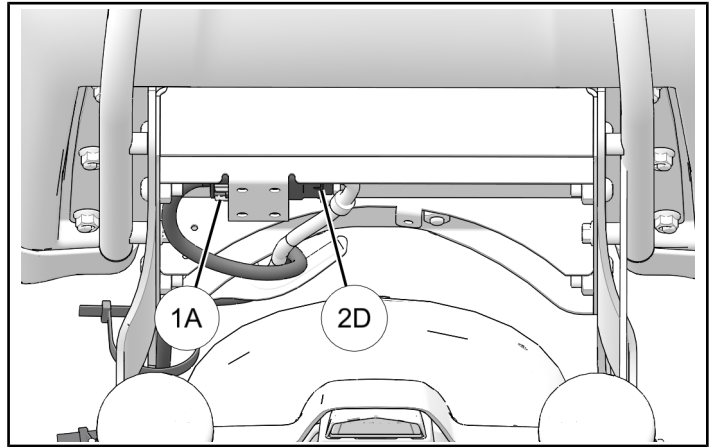

5. Reinstall seat as per owner's manual.

TAMPER RESISTANT INSTALLATION (OPTIONAL)

1. Install two screws **⑨** into trunk frame to securely lock latches.

NOTE

Screws **⑨** are only accessible with hard saddlebags removed.

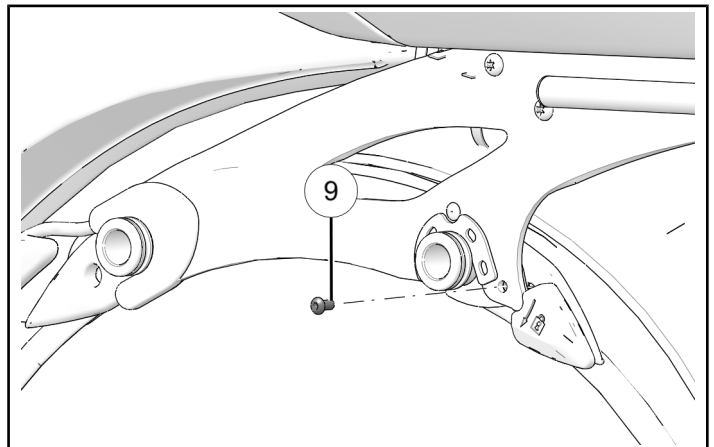

VEHICLE REASSEMBLY

GENERAL

1. Reinstall saddlebags as per owner's manual.

FEEDBACK FORM

A feedback form has been created for the installer to provide any comments, questions or concerns about the installation instructions. The form is viewable on mobile devices by scanning the QR code or by clicking [HERE](#) if viewing on a PC.

