

# WINDSCREEN KIT



**P/N 2880236; 2880237; 2880835**

## APPLICATION

ALL MY15 INDIAN SCOUT MOTORCYCLES.

## ⚠ WARNING

This accessory is only approved for use with the models listed. **NEVER** use this accessory on non-approved models. Use of this accessory on models other than those listed in these instructions may negatively affect the stability of the vehicle, lead to loss of control, and result in serious injury or death.

## BEFORE YOU BEGIN

Read these instructions and check to be sure all parts and tools are accounted for in package. Please retain these installation instructions for future reference and parts ordering information.

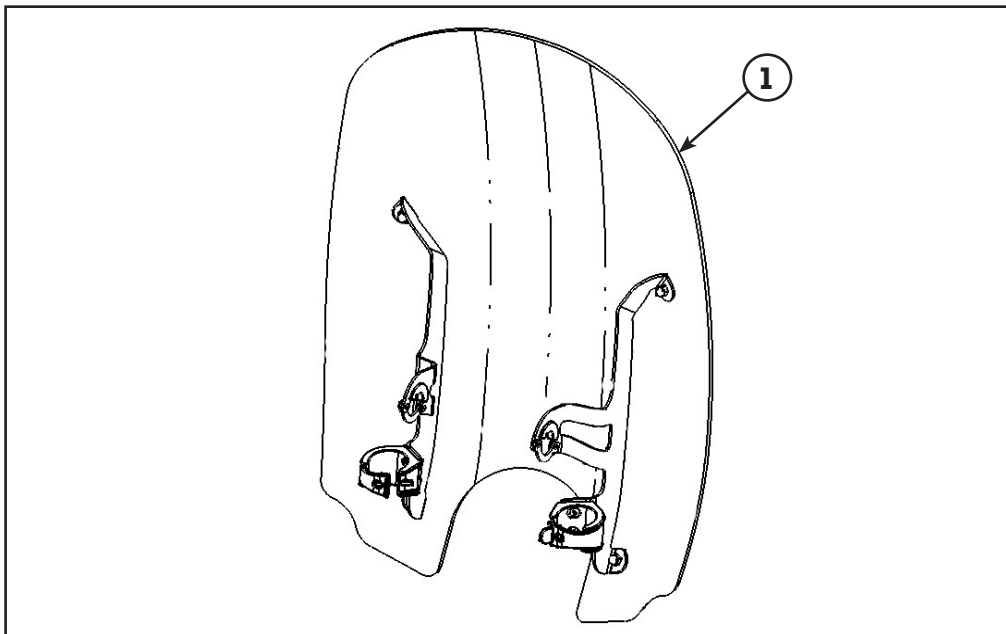

## KIT CONTENTS

Ref	Qty	Part Description	Part Number
1	1	Short Windscreen	2880236
	1	Instructions	9925515
OR			
1	1	Mid Windscreen	2880237
	1	Instructions	9925515
OR			
1	1	Tall Windscreen	2880835
	1	Instructions	9925515

## TOOLS NEEDED

5 mm Hex Key Socket

Socket Wrench

Torque Wrench

## APPROXIMATE ASSEMBLY TIME

6 min

## IMPORTANT

Your Indian WINDSCREEN KIT is exclusively designed for your vehicle. Please read the installation instructions thoroughly before beginning. Installation is easier if the vehicle is clean and free of debris. For your safety, and to ensure a satisfactory installation, perform all installation steps correctly in the sequence shown.

## INSTALLATION INSTRUCTIONS

**NOTE:** Protect all finished surfaces during these operations.

1. Place the windshield (1) assembly onto the handlebar bumpers (A). See Figure 1.

**NOTE:** Make sure the brake line (B) and clutch line (C) are routed over the top of the windshield bracket as shown. Routing them below the bracket may cause abrasion and wear to the lines or other components.

2. Grasp lower portion of windshield and formally rotate windshield down until the fork mount brackets are fully seated to the forks.
3. Fasten the two rubber straps (D) onto the fork mounting brackets (E) by stretching the strap around the fork and then inserting the post in the mounting bracket into the slot in the strap. See Figure 1.

**CAUTION:** The Lexan plastic is easily scratched. Protect it during installation.

### Optional:

For added theft protection, install the locking clip (F) onto the fork mounting brackets using two M6 bolts (G). Torque the bolts to  $36\pm 3$  in-lbs ( $4.06\pm 0.34$  Nm). See Figure 2.

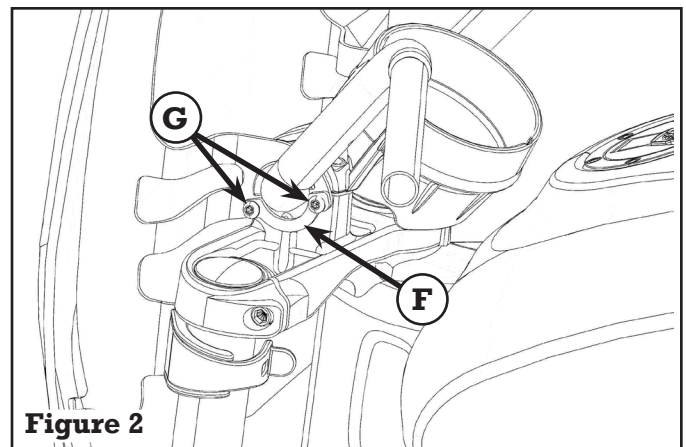
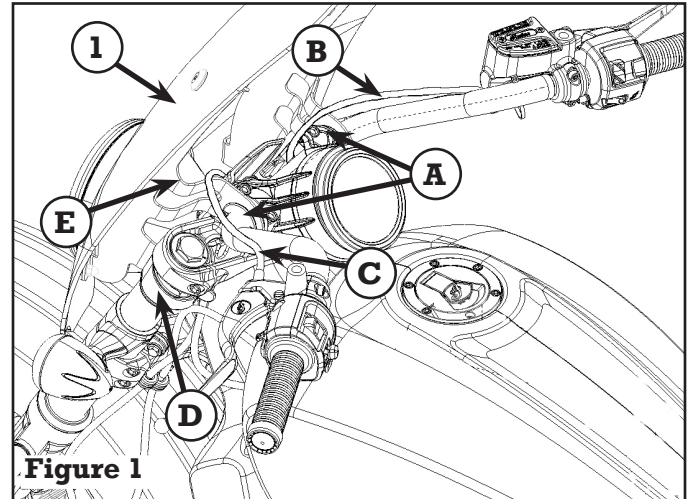

**CAUTION:** Do not use glass cleaner, water or soil repellents, petroleum or alcohol based cleaners as the product can damage the Lexan (plastic) material on the deflectors.