



PLOW MOUNT KIT

FOR CF MOTO UFORCE 1000

P/N 34-9020

ASSEMBLY / OWNERS MANUAL

Application

PLOW PUSH FRAME NO. 34-0000 or 34-0070

Before you begin, please read these instructions and check to be sure all parts and tools are accounted for. The following instructions contain details required to install and service the contents of this kit.

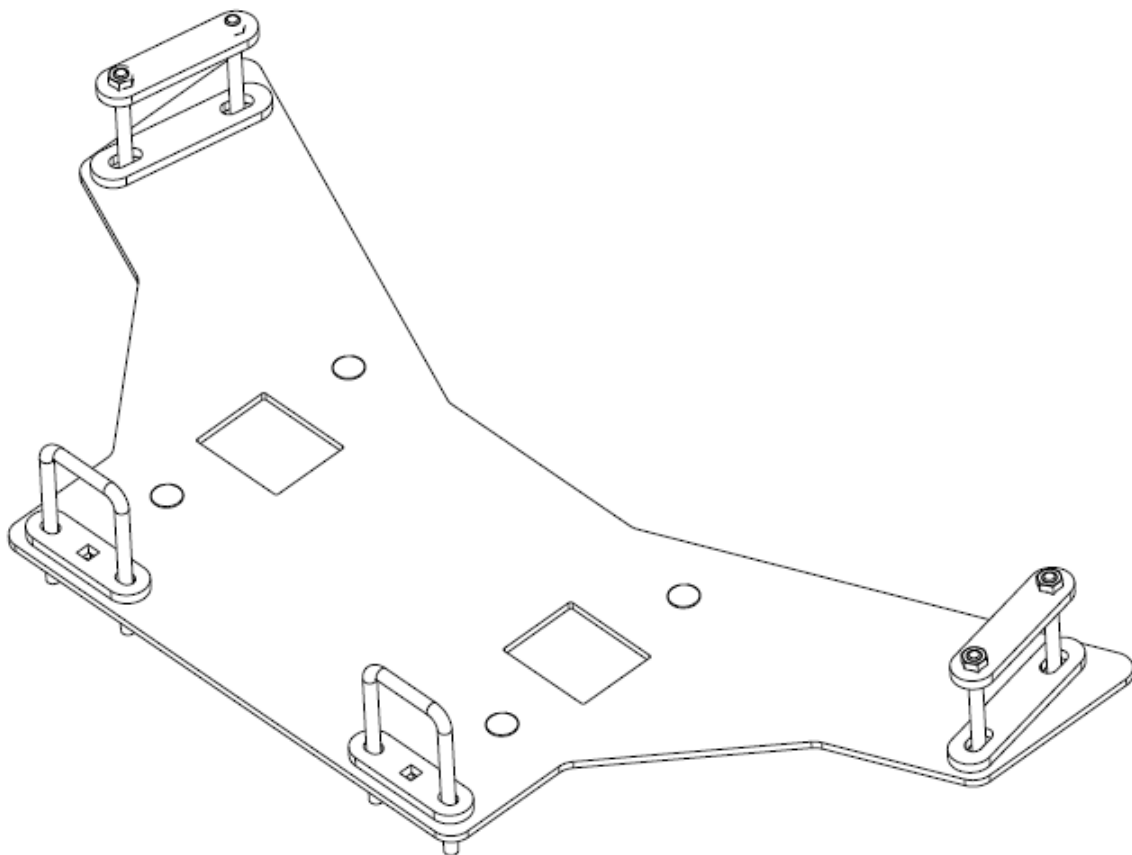

OPERATING INSTRUCTIONS

Congratulations! You've just purchased the most durable plow component in the industry. Kolpin plow components work great for summer or winter plowing. With proper care and maintenance, your Kolpin plow system will last for years to come!

NOTICE
Plow operation requires additional components for operation: <i>Kolpin Plow Blade, Kolpin Plow Push Frame, High Rise Plow Push Frame, Winch Kit</i> *
<i>*These components may be specific to your vehicle.</i>



Please read and understand all assembly instructions, notices and warnings before assembling and operating your Kolpin plow system.

Follow these guidelines to ensure satisfactory operation:

- Read this manual and your ATV/ UTV operators manual before use.
- Periodically check for wear and tightness of all fasteners. Replace or re-torque fasteners as necessary.
- Before first use, set plow in the furthest right or left angled position to check for interference with the vehicle.
- Operate with extreme caution on slopes and rough terrain. Be familiar with the area before you plow.
- Be aware of immovable objects that could be hidden in the area you are plowing.
- To avoid damage when pushing snow into a pile, reverse direction before raising the plow blade.
- Do not ram the plow blade into piles of snow.
- For best results, set the suspension preload of your ATV/ UTV to the stiffest setting.
- To reduce steering effort and increase mobility, set the air pressure of your tires to the maximum pressure specification.
- The plow skids are adjustable. General skid setting is even with the plow wear bar bottom edge, higher settings reduce the chance of rocks and gravel from being collected.
- To increase traction during plow operation, operators can try: Securing weight to the ATV/ UTV for additional tire downforce, reducing tire air pressure, or installing tire chains.

SAFETY INFORMATION

Our plow systems were designed with your safety in mind. Please read and understand all Cautions, Notices and Warnings in this manual before you begin. In order to protect you and your ATV/UTV, certain parts of the plow system and/or hardware are designed to fail when the equipment is over-stressed.

 WARNING 
TO AVOID SERIOUS INJURY OR DEATH:
1. DO NOT EXCEED 5 MPH (8 KMH) WITH BLADE INSTALLED
2. OPERATE WITH EXTREME CAUTION ON SLOPES, STEEP GRADES, AND ROUGH TERRAIN
3. ALLOW NO RIDERS ON BLADE OR ATV WHILE MOVING OR STATIONARY
4. KEEP BYSTANDERS AWAY FROM THE BLADE OR ATV WHILE MOVING OR STATIONARY
5. WHEN PUSHING HEAVY MATERIAL, DIRECTION CONTROL MAY BECOME DIFFICULT
6. BEFORE ADJUSTING BLADE: STOP ATV ENGINE; SET AND LOCK BRAKES; RAISE AND LOCK BLADE
7. LOWER BLADE TO DOWN POSITION WHEN BLADE AND ATV ARE NOT IN USE
8. READ BLADE INSTRUCTION SHEETS AND ATV OWNER'S MANUAL

Kit Contents:

Item	Qty	Part Description	Part Number
1	1	UForce Mount Plate	-
2	2	Welded Nut Bracket	-
3	2	Front Spacer Bracket	-
4	2	Rear Spacer Bracket	-
5	2	Square U-Bolts, M8-1.25 x 105mm	-
6	4	Hex Bolt, Zinc Plated, M8-1.25 x 80mm LG	-
7	4	Flat Washer, Zinc Plated, M8	-
8	4	Lock Washer, Zinc Plated, M8	-
9	4	Carriage Bolt, Zinc Plated, M8-1.25 x 25mm LG	-
10	8	Flange Locknut, Zinc Plated, M8-1.25	-
11	1	Instruction Guide (not shown)	-

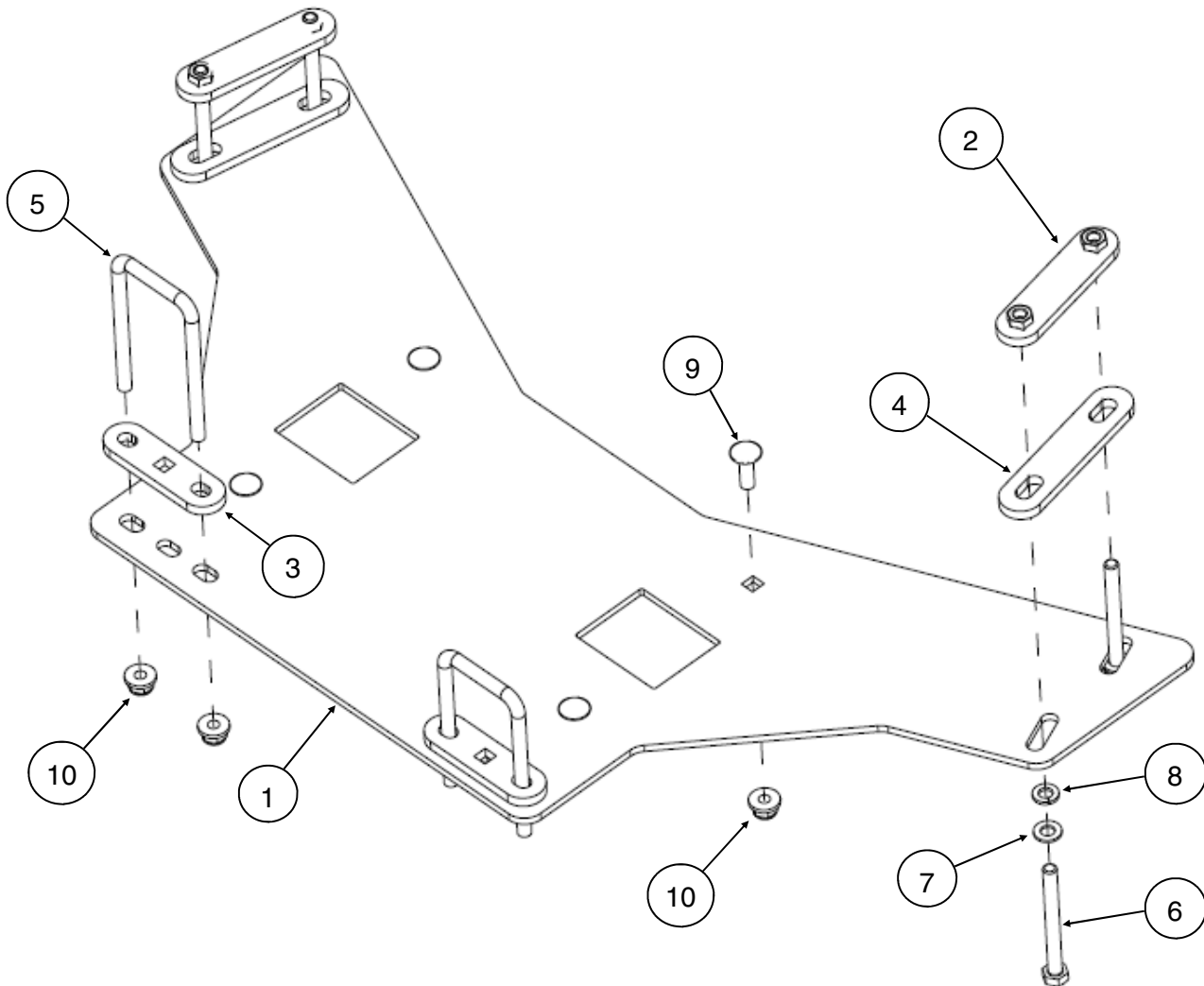

BEFORE YOU BEGIN:

- Your Kolpin accessory is exclusively designed for your vehicle
- Please read and understand all instructions
- Verify all parts and tools are accounted for
- To ensure a satisfactory installation, follow all steps correctly and in the sequence described
- Keep these instructions for future reference or for informational requests
- To facilitate installation, make sure that your vehicle is clean and free of debris
- All directions referring to right and left are when the rider is sitting on the machine
- The plastic skid plate will need to be modified to be reinstalled on the vehicle.

TOOLS REQUIRED:

- Standard Metric Wrench and Socket Set
- Drill or cutting tools for plastic

APPROXIMATE ASSEMBLY TIME: 30 minutes

Note: Removal and modification of the plastic skid plate is recommended.

Note: Additional time may be required to accommodate other installed accessories.

Note: If any hardware is missing, do not return to the store. Call us to help, Toll Free 1-877-956-5746.

SPARE KITS		Hardware kit P/N 34-0010
Item	Description	
5	Square U-Bolts, M8-1.25 x 105mm	4x
6	Hex Bolt, Zinc Plated, M8-1.25 90mm LG	2x
7	Flat Washer, Zinc Plated, M8	2x
8	Spring Lock Washer, Zinc Plated, M8	2x
9	Carriage Bolt, Zinc Plated, M8-1.25 x 25mm LG	4x
10	Flange Locknut, Zinc Plated, M8-1.25	12x
-	Flange Locknut, Zinc Plated, M10-1.5	2x
-	Hex Nut, Zinc Plated, M8-1.25	2x
-	Hex Bolt, Zinc Plated, M8-1.25 45mm LG	2x
-	Carriage Bolt, Zinc Plated, M10-1.5 x 40mm LG	2x

Spare Kit Notes:

- Spare kits may contain extra hardware that is used for other mount kits. Extra hardware can be discarded.
- U-bolts supplied in spare kits may be longer than original and may need to be cut to size.

Installation Prep:

1. Detach the Front plastic skid plate and two RH/LH side plastic skid plates from the vehicle by removing the OEM fasteners as shown and save for later. (See illustration 1-1).
2. From under the vehicle, align the mount plate (item #1) with the frame. Center the mount plate side to side on the vehicle frame as shown. (See illustrations 1-2 and 1-3).
3. Using the mount plate (item #1) as a pattern template, scribe or mark the u-bolt / bolt hole locations into the plastic skid plates.
4. Drill holes through the skid plate at locations marked. Use a 3/8" to 1/2" bit to create an oversized hole that will allow some relief when installing hardware. (See illustration 1-2).
Note, a high speed cutting tool (like a Dremel) with a cutting bit will also work.

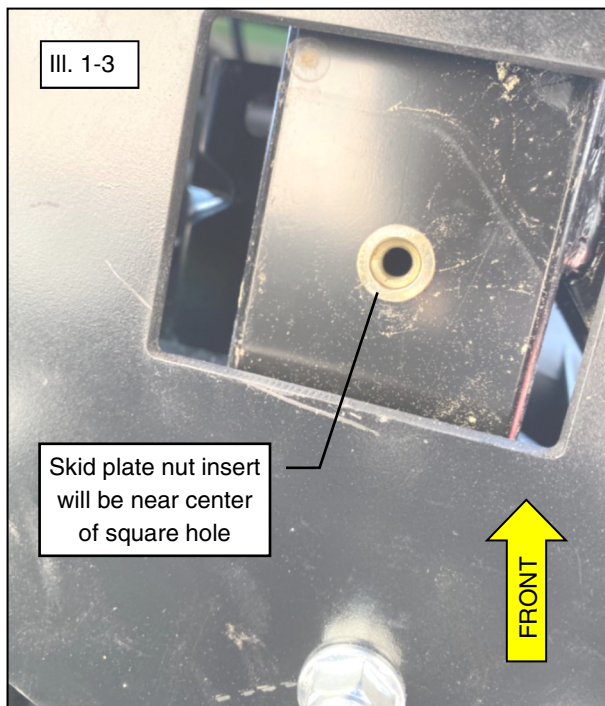
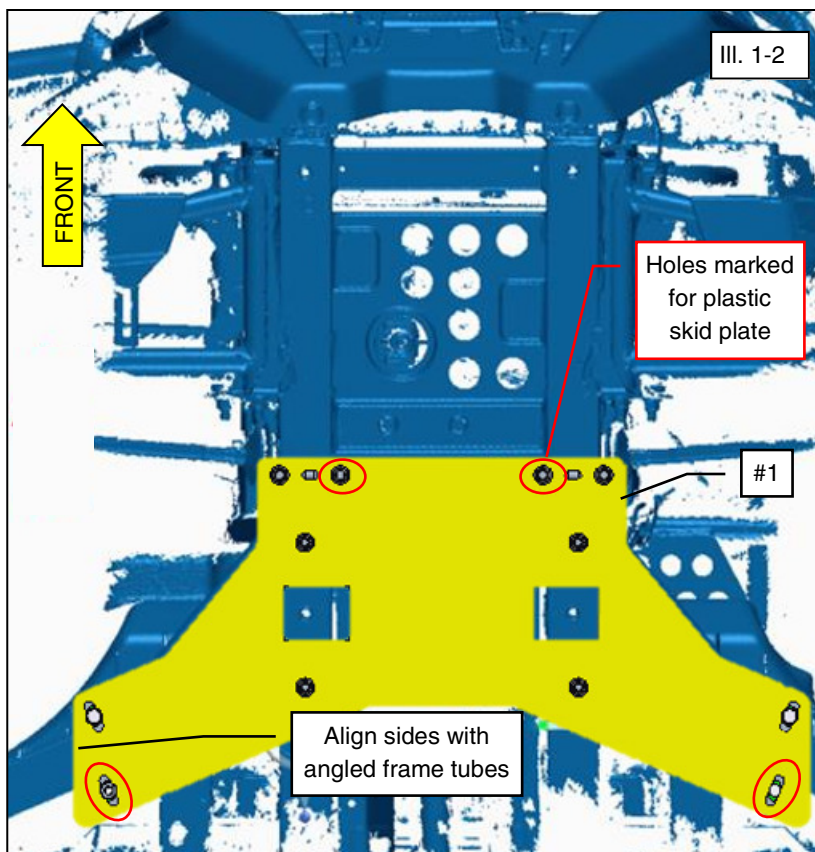
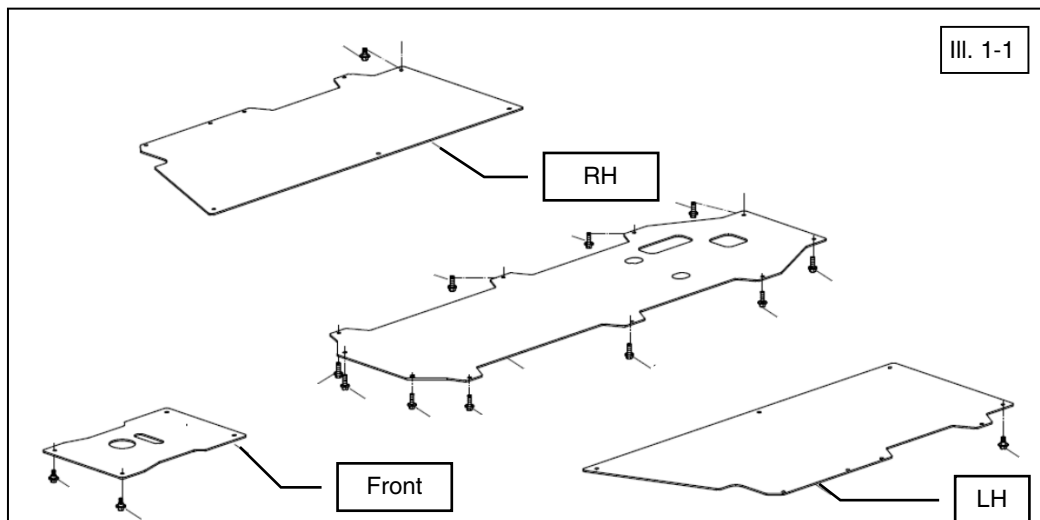

Mount Plate Installation:

5. Re-install the plastic skid plates onto the vehicle with the OEM hardware and position the u-bolts (item #5) through the drilled out sections as shown. (See illustration 1-4).
6. From under the vehicle, position the u-bolts (item #5) around the frame as shown.
7. Install the plow mount plate (item #1) onto the vehicle. The front spacer bracket (item #3) will fit between the plastic skid plate and mount plate (item #1). The u-bolts (item #5) will fit thru holes in the plate as shown. Fasten the u-bolts with the M8 locknuts (item #10). (See illustrations 1-4 and 1-5).
Note, do not tighten at this step.

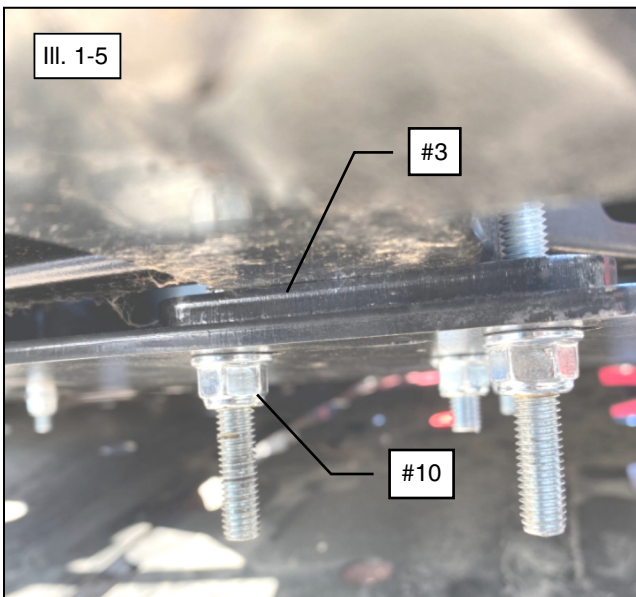
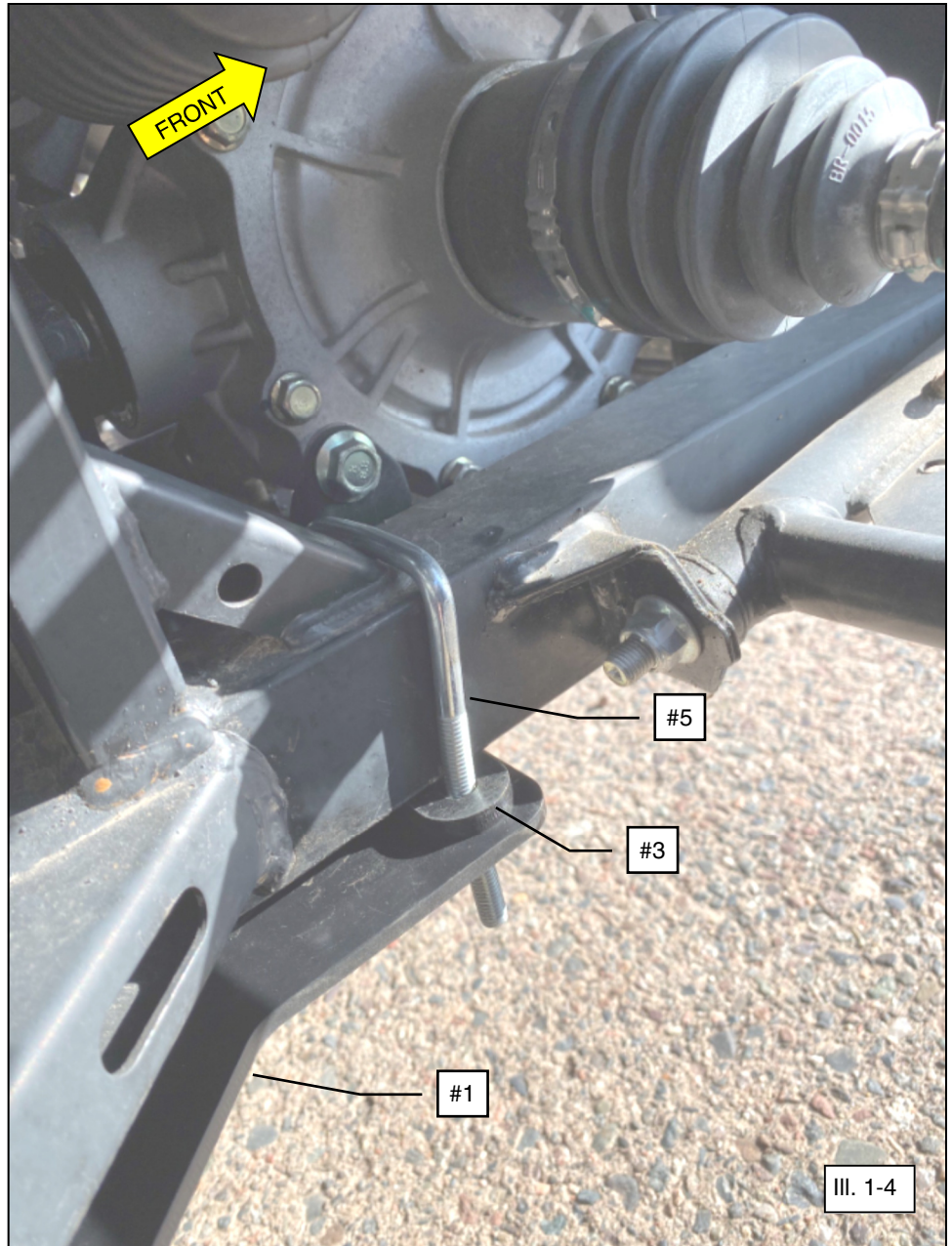

Mount Plate Installation (continued):

8. Insert the M8 carriage bolts (item #9) thru the plate as shown on page 3 and loosely fasten with locknuts (item #10). (See illustration 1-7).
9. Position the welded nut brackets (item #2) over the angled frame tubes as shown. The nut brackets will fit in between the floorboard and frame. Lift the rear of the mount plate up to vehicle skid plates and secure the plate into position using the long hex bolts (item #6), lock washers (item #8) and flat washers (item #7). Thread the bolts into the welded nut brackets (item #2). (See illustrations 1-6 and 1-7). **Note, the rear spacer bracket (item #4) will fit in between the plastic skid plate and mount plate.**
10. Excessive bolt length can be trimmed from u-bolts (item #5), 3-4 threads past nut locking patch. (See illustration 1-7). **Note, skid plate not shown for clarity.**
11. The universal mount plate (not included) will be attached to the mount plate. The M8 carriage bolts (item #9) will fasten the universal plate (not included) with M8 locknuts (item #10). Tighten all M8 hardware to specification. (See illustration 1-7).

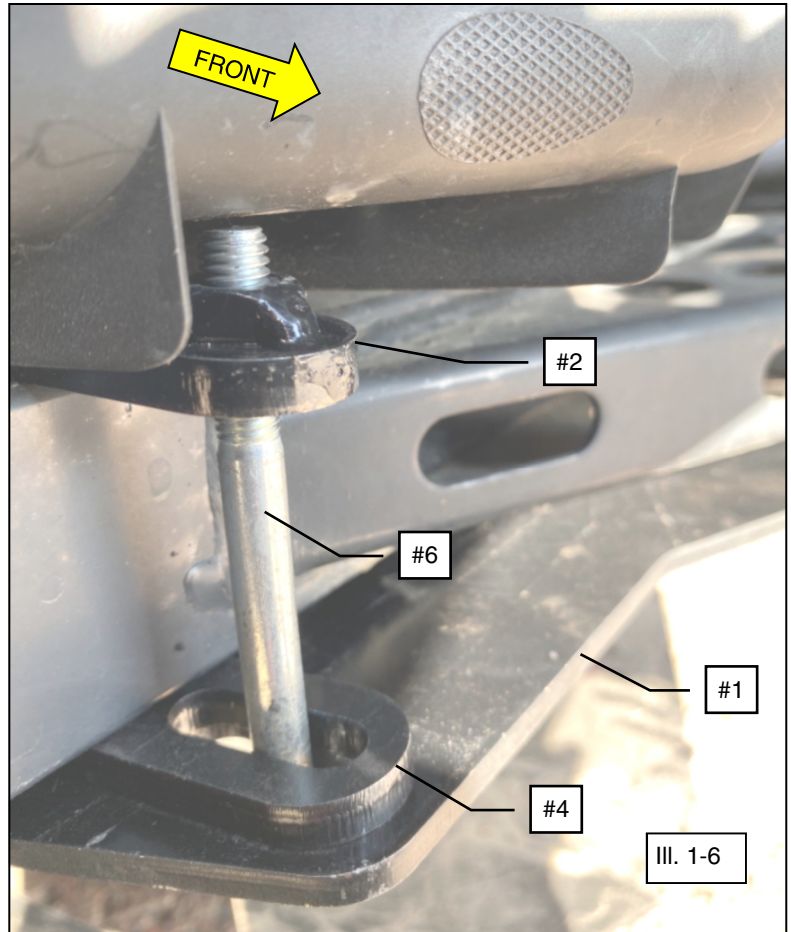

 = T
8MM FASTENER TORQUE: 17 ft. lbs. (23 Nm)

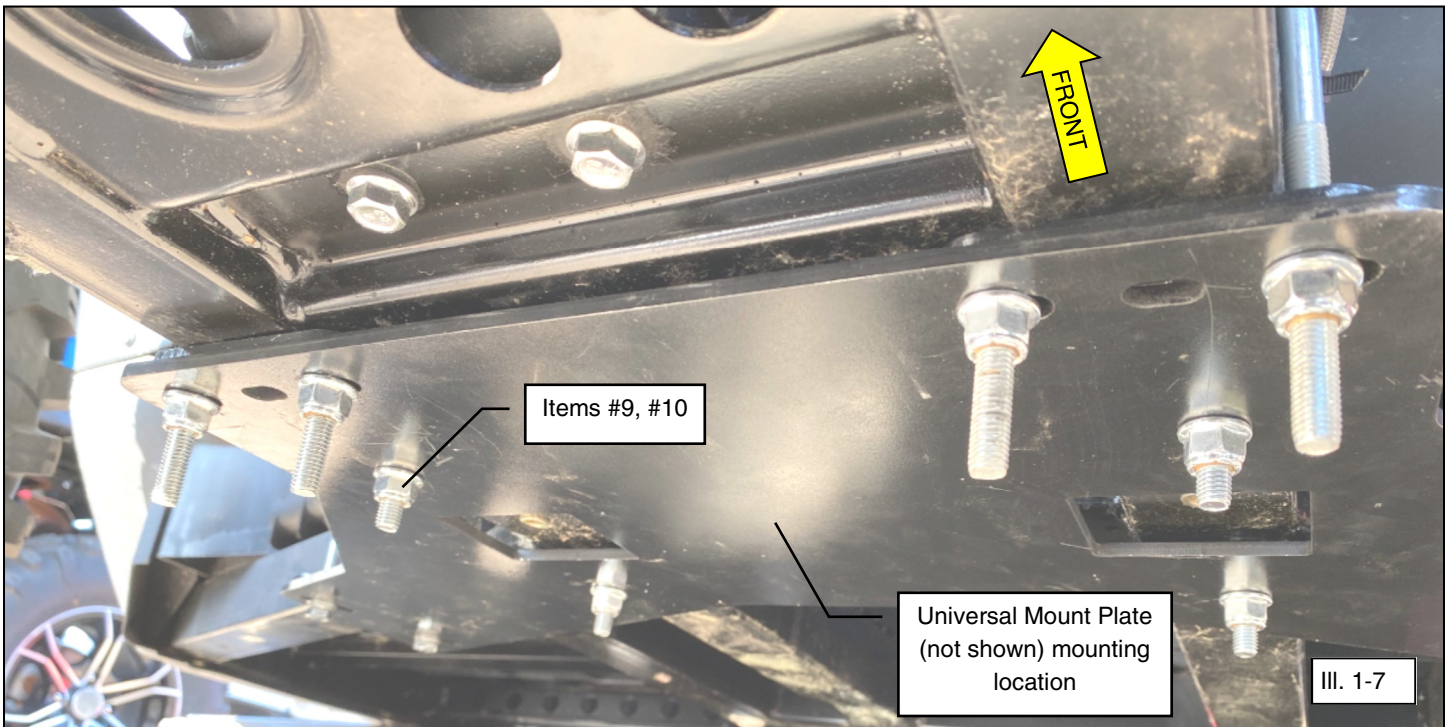



One Year Limited Warranty

For the period of one (1) year from the purchase date, Kolpin will replace for the original purchaser, free of charge, any part or parts found upon examination by Kolpin to be defective in material, workmanship, or both.

All transportation costs incurred submitting product to Kolpin for warranty consideration must be borne by the purchaser. If Kolpin determines that the product must be returned to the factory for credit, please call 1-877-956-5746 for a Return Merchandise Authorization (RMA) number and shipping instructions.

This warranty does not apply to parts that have been damaged by accident, alteration, abuse, improper maintenance, normal wear, or other causes beyond the manufacturer's control. In order to protect you and your ATV, certain parts of the accessory system and/or hardware are designed to fail when the equipment is over-stressed. Parts that are lost due to loosening and improper maintenance are not covered under warranty. This warranty does not cover removal or reinstallation labor fees of the plow system and related components.

Peripheral products such as engines, electric motors, and actuators may carry an original manufacturer's warranty. Most hardware is general in nature and is easily obtained locally. Be sure to replace with minimum metric class 8.8 specification.

Kolpin Outdoors, Inc.

Telephone: (763)-478-5800

Toll Free: (877)-956-5746

Fax Number: (800)-245-7569

www.kolpin.com

Email: customerservice@kolpin.com