

SOUND BAR HARNESS KIT



P/N 2882280

APPLICATION

Verify accessory fitment at Polaris.com.

BEFORE YOU BEGIN

Read these instructions and check to be sure all parts and tools are accounted for. Please retain these installation instructions for future reference and parts ordering information.

KIT CONTENTS

This kit contains parts for installation of the Sound Bar Harness only. Prior installation of one of the following Battery Connection Kits is also required (sold separately):

- PN 2879862, 2881551, or equivalent (2 passenger RZR)
- PN 2880055, 2881646, or equivalent (4 passenger RZR)

This Kit includes:

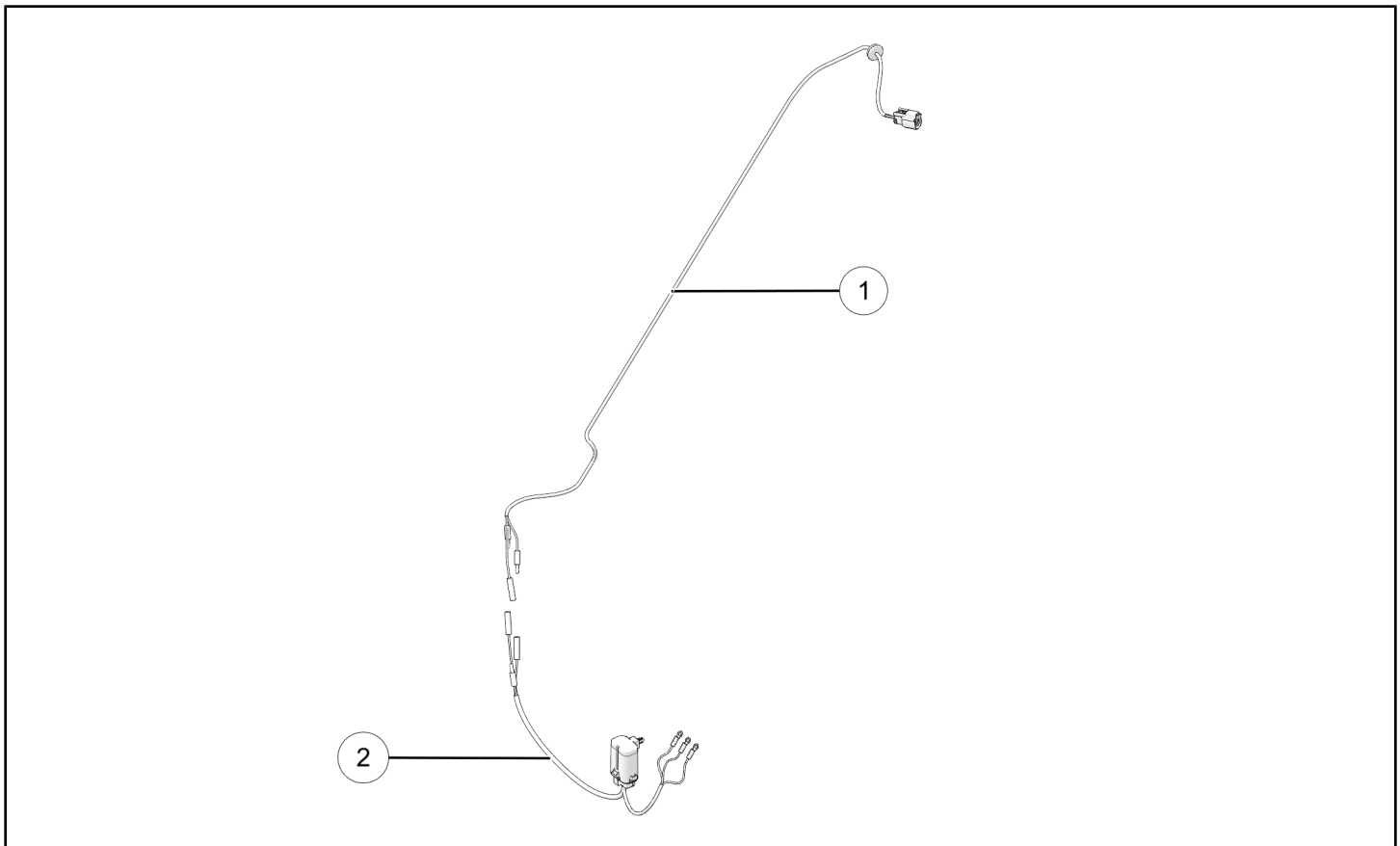

REF	QTY	PART DESCRIPTION	PART NUMBER
1	1	Harness, ROPS	2413510
2	1	Harness, Dash	2413509
3	3	Cable Tie, 11 inch (not shown)	7080492
	1	Instructions	9927518

TOOLS REQUIRED

- Safety Glasses
- Drill
- Drill Bit: 1/4 inch
- Socket Set, Metric
- Wrench Set, Metric

IMPORTANT

Your Sound Bar Harness Kit is exclusively designed for your vehicle. Please read the installation instructions thoroughly before beginning. Installation is easier if the vehicle is clean and free of debris. For your safety, and to ensure a satisfactory installation, perform all installation steps correctly in the sequence shown.

ASSEMBLY TIME

Approximately 20 minutes

INSTALLATION INSTRUCTIONS

1. Shift vehicle transmission into "PARK". Turn key to "OFF" position and remove from vehicle.
2. Gain Access.
 - a. Remove hood.
 - b. Remove driver's (or left rear passenger) seat to gain battery access.
3. Disconnect black negative (-) cable from battery.
4. Install ROPS harness.
 - a. Route three bullet connectors on ROPS harness ① into oval hole at top of passenger side A-pillar, down ROPS, out of welded coupler at base of pillar, and into under-hood compartment (forward side of firewall) as shown.

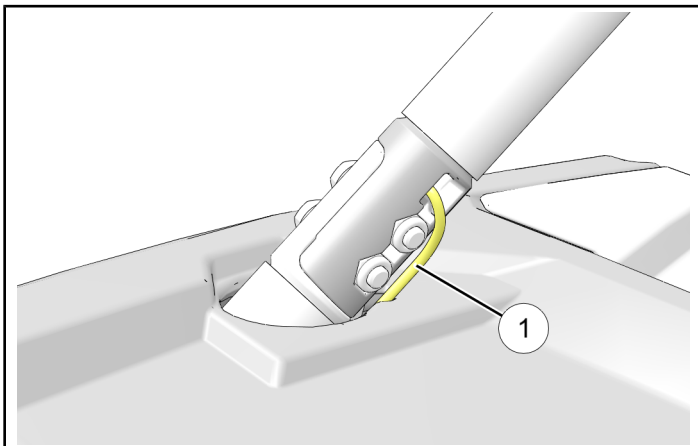
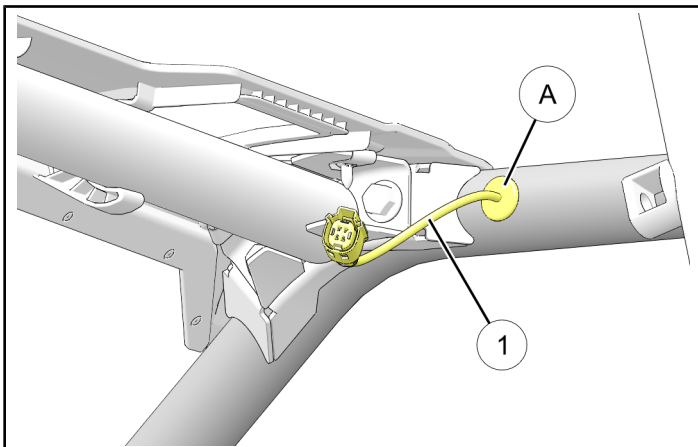

- b. Connect 4-pin connector at top of ROPS harness ① to sound bar (purchased separately).
- c. Install rubber grommet (A) on ROPS harness ① in hole at top of passenger side A-pillar as previously shown.

5. Install dash harness.
 - a. Connect three bullet connectors on dash harness ② to corresponding bullet connectors on ROPS harness ①.

NOTE

Bullet connector lengths on each harness are staggered to assist in identifying proper connections.

- b. Drill out one accessory plug (1/4 inch) on forward side of firewall, below and outboard of terminal block, then install fuse/relay block (B) using attached fir tree clip as shown.

IMPORTANT

Control drill depth to prevent damage to underlying structure or components.

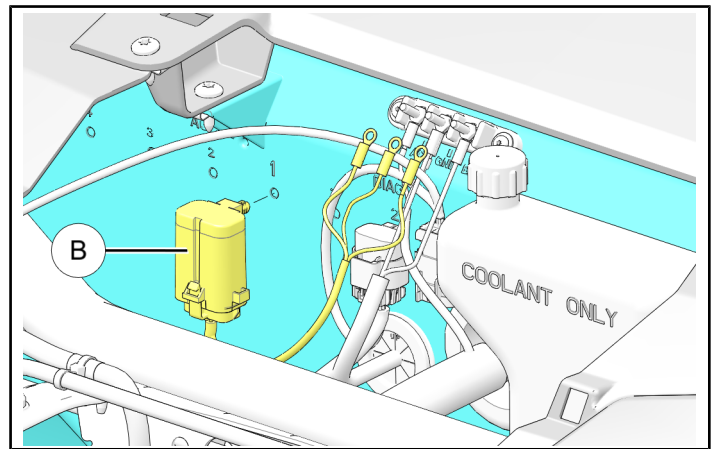

- c. Connect dash harness ② ring terminals to terminal block:
 - **"BATT"/RED** harness wire: To post with existing RED battery connection cable (unswitched 12V POS); post may be identified as "BAT"
 - **"ACC"/ORANGE** harness wire: To post with existing ORANGE wire (accessory switched 12V POS); post may be identified as "ACC"
 - **"GND"/BROWN** harness wire: To post with existing BLACK battery connection cable (12V NEG); post may be identified as "GND"
- d. Secure dash harness ② using cable ties ③ to prevent contact with hot components, sharp edges, or moving parts. Coil and secure excess harness length in under-hood compartment.

6. Reconnect black negative (-) cable to battery.
7. Restore access.