

HORN KIT

P/N 2879273



Application

MY13 Ranger 900 XP

Before you begin, read these instructions twice and check to be sure all parts and tools are accounted for. Please retain these installation instructions for future reference and parts ordering information.

This Kit Includes:

<u>Qty</u>	<u>Part Description</u>	<u>Part Number</u>
1.....	Harness-Wire, Horn, TT	2412421
1.....	Switch-Horn, Ranger	4010652
1.....	Horn	4011408
5.....	Panduit Strap	7080138
1.....	Instructions	9924150

Tools Required:

Metric and Standard Socket Set
Drill

Metric and Standard Wrench Set
1/4" Drill Bit

3/4" Hole saw

NOTE: This kit requires previous installation of power and ground wires to the terminal block (bus bar), which are included with stereo kit 2879248, Polaris or WARN winch kits for Ranger 900 XP, or can be purchase separately as kit 4014060.

IMPORTANT: Your Polaris Ranger horn is exclusively designed for your vehicle. For your safety and to ensure a satisfactory installation, please read the installation instructions thoroughly before beginning. Perform all installation steps correctly and in the sequence shown. Installation of any item is easier if the vehicle is clean and free of debris.

INSTALLATION INSTRUCTIONS

1. Place vehicle in PARK and remove key from ignition. Remove or tip up the windshield if installed.
2. Remove dash cap from vehicle by removing four plastic push darts located along front edge of dash cap.
3. Remove hood from vehicle. Locate the radiator brace closest to the radiator cap. Remove the screw shown in Figure 1. If necessary, loosen the nut on the horn that holds the mounting bracket in place and re-orient the mounting bracket so it is oriented as shown.
4. Position the horn and mounting bracket. (Figure 1). Reinstall the screw that was removed from the radiator brace.

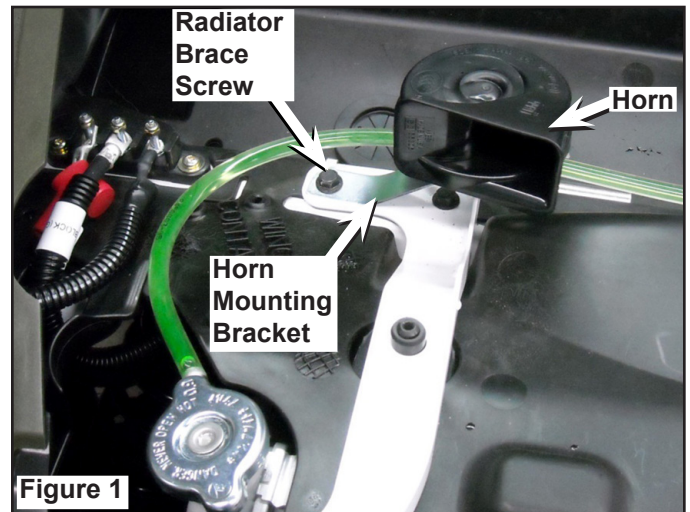

5. Install the wire harness through the rubber grommet in the dash. The brown and blue/white wires will route under the dash and connect to the horn button.
6. Locate a proper location in the dash for the switch to be installed. Polaris recommends that it be installed on the console directly below the gearshift. Drill a $\frac{3}{4}$ " holes for the switch, making sure not to damage any other components when drilling.



Figure 2

7. Remove the locking washer and nut from the switch and slip the nut and the washer over the harness wires for the switch.
8. Insert the switch into the dash and secure it with the washer and the nut removed at Step 7.

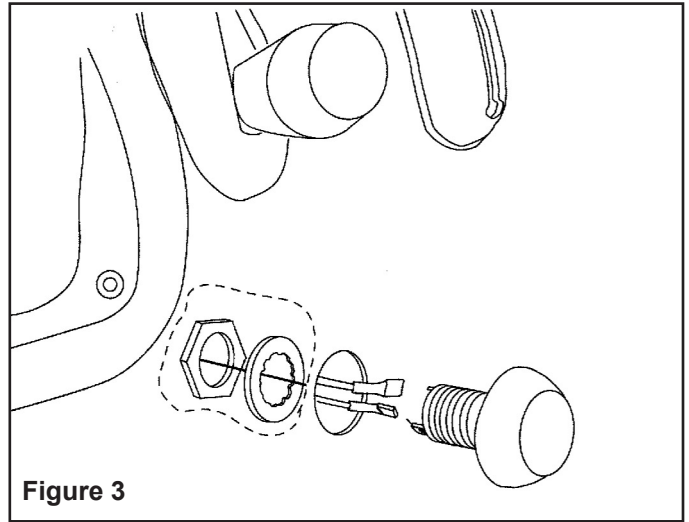

Figure 3

9. Connect the red and blue/white wires to the terminals on the horn. Connect the red and brown wires with ring terminals to the terminal block (bus bar) as shown in Figure 4. The red wire should be connected to keyed power. If you want the horn to work only when the key is on, or connected to the constant power terminal if you want the horn to be operable at all times. Connect the blue/white and brown wires to the horn.

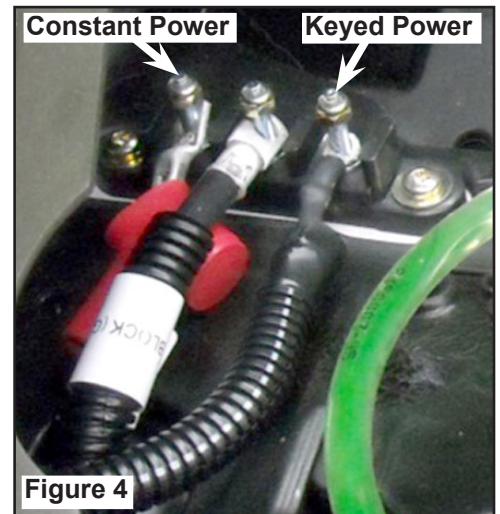

Figure 4