

FRONT BUMPER KIT



P/N 2882301

APPLICATION

Verify accessory fitment at Polaris.com.

BEFORE YOU BEGIN

Read these instructions and check to be sure all parts and tools are accounted for. Please retain these installation instructions for future reference and parts ordering information.

KIT CONTENTS

This Kit includes:

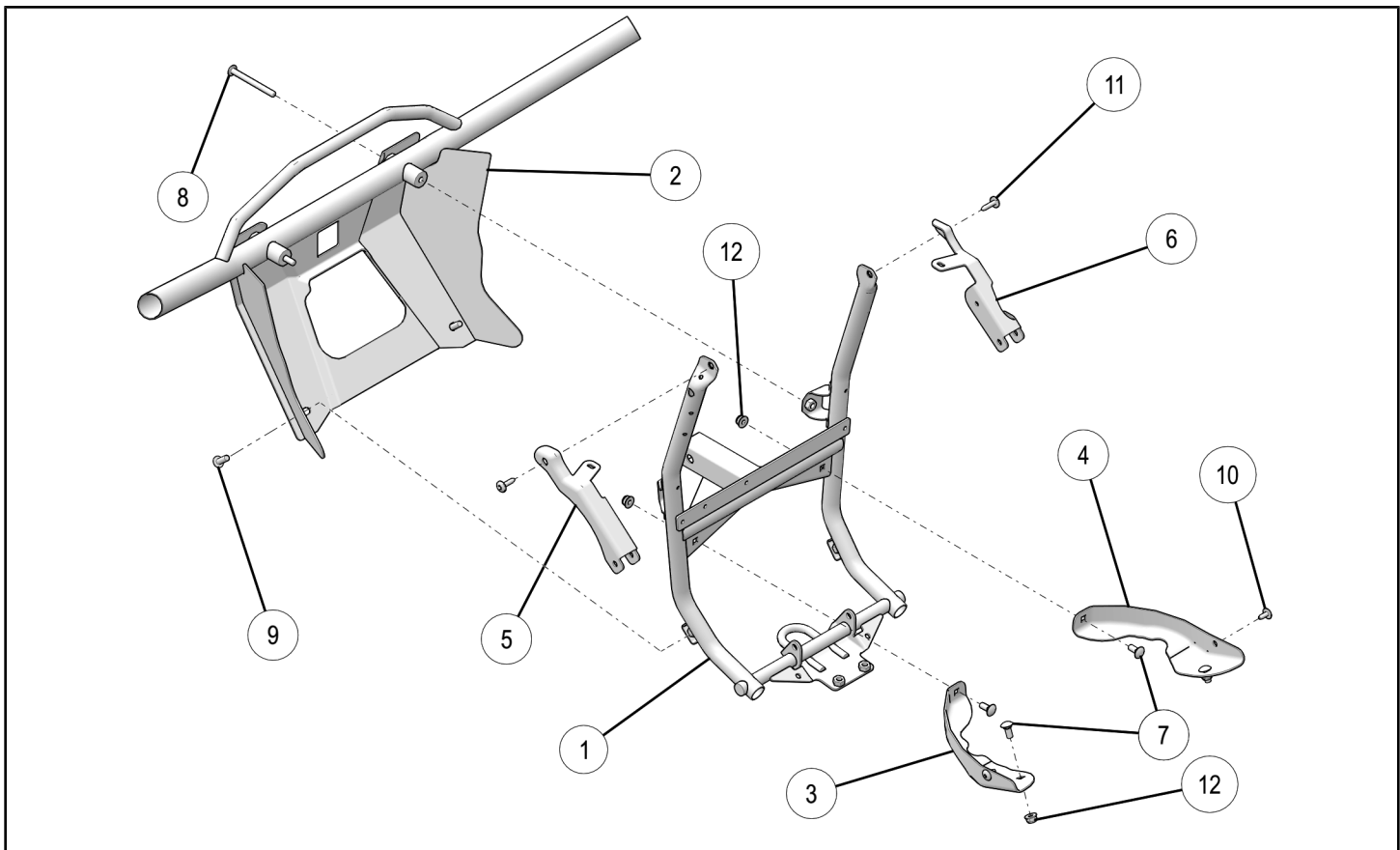

REF	QTY	PART DESCRIPTION	PART NUMBER
1	1	Bumper Support, Welded	1022511
2	1	Front Bumper, Welded	1022574
3	1	Lower Support Bracket, LH	5262782
4	1	Lower Support Bracket, RH	5262783
5	1	Upper Support Bracket, LH	5263043
6	1	Upper Support Bracket, RH	5263044
7	4	Screw, Carriage - 5/16 -18 X 0.75	7512377

REF	QTY	PART DESCRIPTION	PART NUMBER
8	2	Screw, Torx® - 5/16 -18 X 3.25	7518215
9	2	Screw, Torx® - 5/16 -18 X 7/8	7518216
10	2	Screw, Torx® - M6 X 1.0 X 15	7519092
11	2	Screw, Torx® - M6 X 1.0 X 25	7519650
12	4	Nut, Hex Flange - 5/16 -18	7542343
	1	Instructions	9927755

TOOLS REQUIRED

- Safety Glasses
- Metric Wrench Set
- Metric Socket Set
- Torx® Wrenches

IMPORTANT

Your FRONT BUMPER KIT is exclusively designed for your vehicle. Please read the installation instructions thoroughly before beginning. Installation is easier if the vehicle is clean and free of debris. For your safety, and to ensure a satisfactory installation, perform all installation steps correctly in the sequence shown.

ASSEMBLY TIME

Approximately 1 hour

INSTALLATION INSTRUCTIONS

1. Shift vehicle transmission into "PARK". Turn key to "OFF" position and remove from vehicle.
2. Disconnect the battery negative (-) and positive (+) cables from battery.
3. Detach the rubber latches (A) from both sides of the front rack (B).
4. Open the front rack (B) as shown.

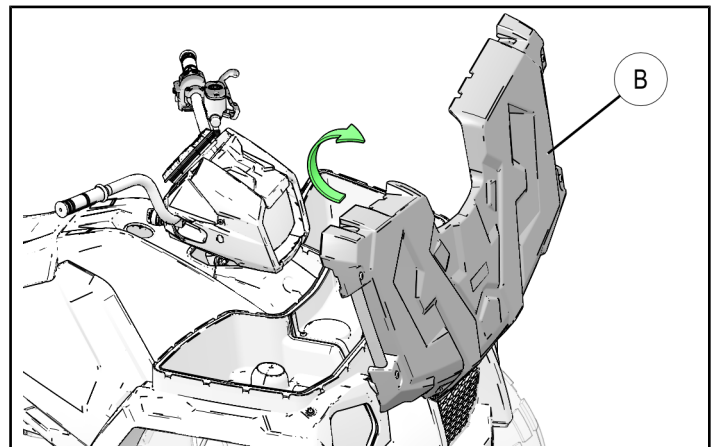
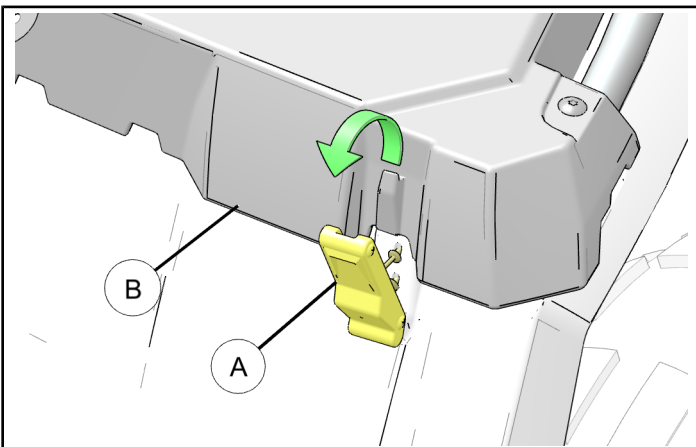

5. Remove two screws (C) holding the front rack cables (D) in place. Retain fasteners for reuse.

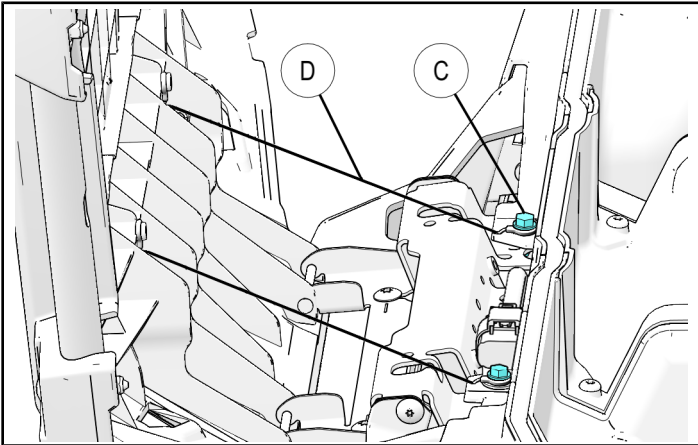

8. Remove the pivot bracket (J) by removing two screws (H). Retain hardware for reuse.

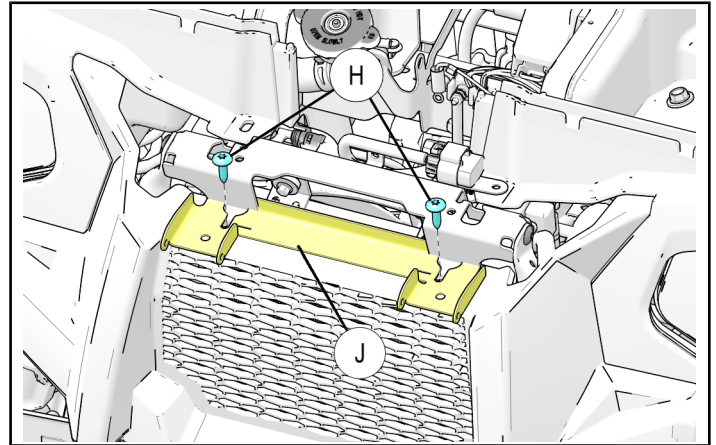

6. Remove two hinge pins (E) to detach the front rack (B) from vehicle. Set the front rack aside and retain hinge pins.

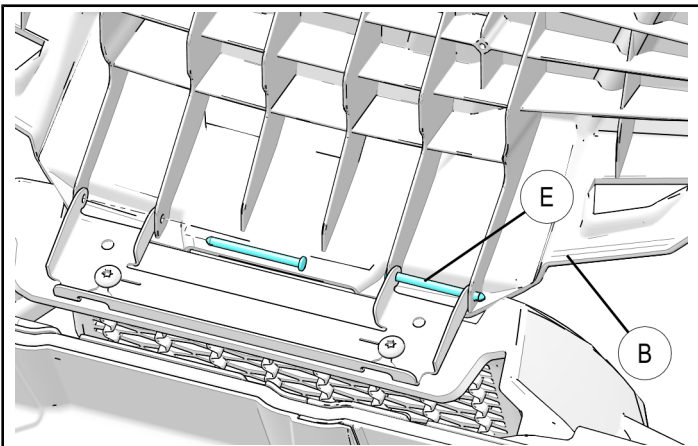

9. Remove lower fascia fasteners (K) (L) and pull the fascia (M) forward and down to remove. Retain hardware for reuse.

NOTE
Lower fascia (M) will not be used again for this application.

7. Remove the storage access panel (F) by removing four screws (G). Retain hardware for reuse.

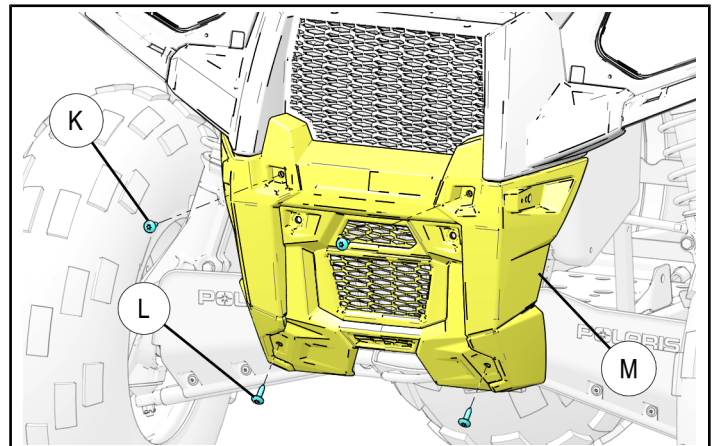
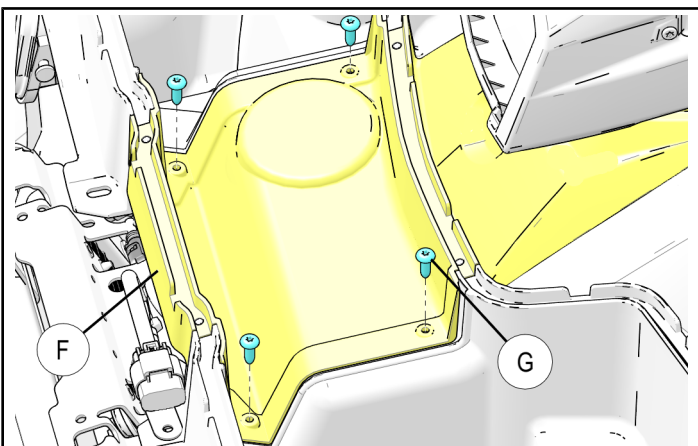

10. Disconnect headlight connectors (N) on both sides.

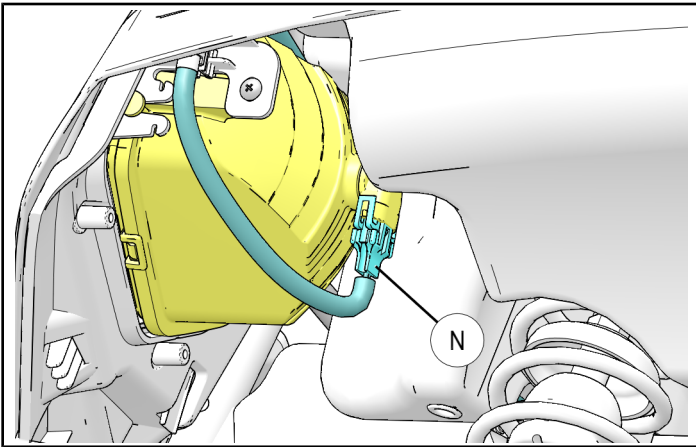

11. Remove push darts (P) from both sides holding the upper fascia (Q) in place. Remove fascia from the vehicle. Retain push darts for reuse.

NOTE

The Pliers in the vehicle tool kit are specially designed to remove push darts (P).

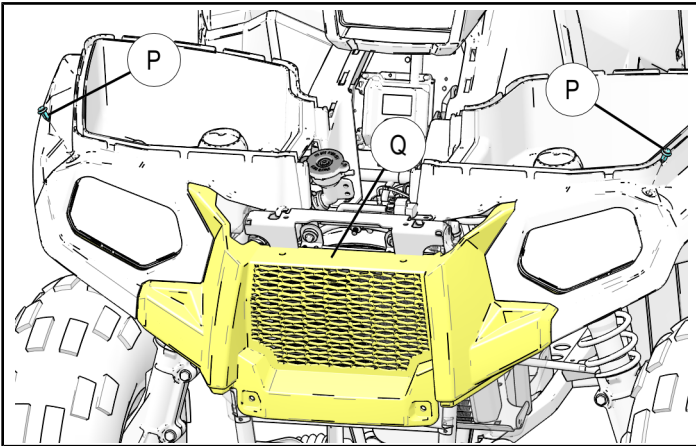

12. Remove the regulator (S) by removing two screws (R) from the stock bumper support (T). Retain hardware for reuse.

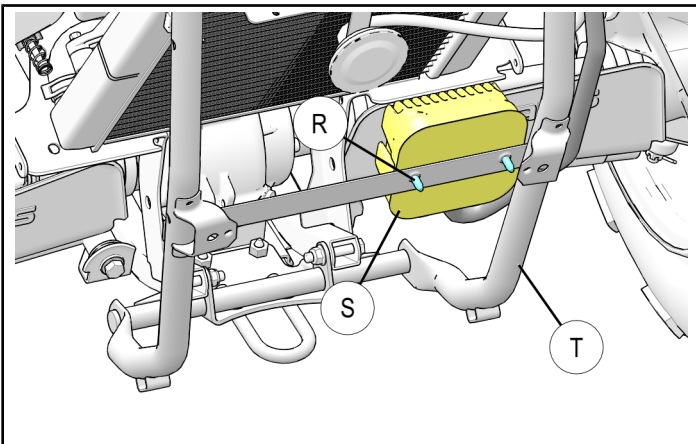

13. Remove two screws (U) holding stock bumper support (T) onto upper radiator bracket (V) at the top as shown. Discard both the screws (U).

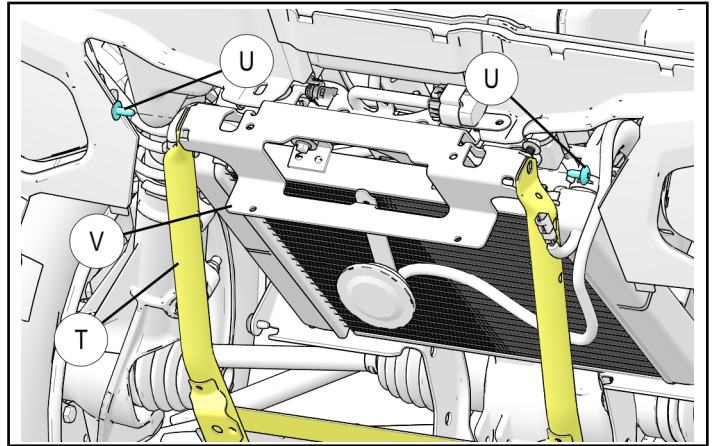

14. Remove four bolts (W) (X) and two nuts (Y) holding stock bumper support (T) in place at the bottom. Retain hardware for reuse.

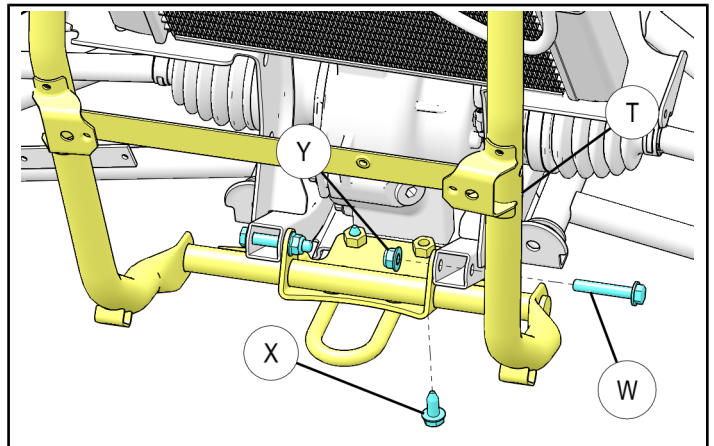

15. Remove two bolts (Z) and nuts (AA) from the chassis. Reinstall the upper support brackets ⑤ ⑥ supplied with kit and reinstall fasteners (Z) and (AA). Torque bolts (Z) to specification.

TORQUE

10 ft. lbs. (13.5 Nm)

NOTE

The upper tab (circled below) on support brackets ⑤ ⑥ slides underneath the body plastic (AB) on both sides as shown in second image below.

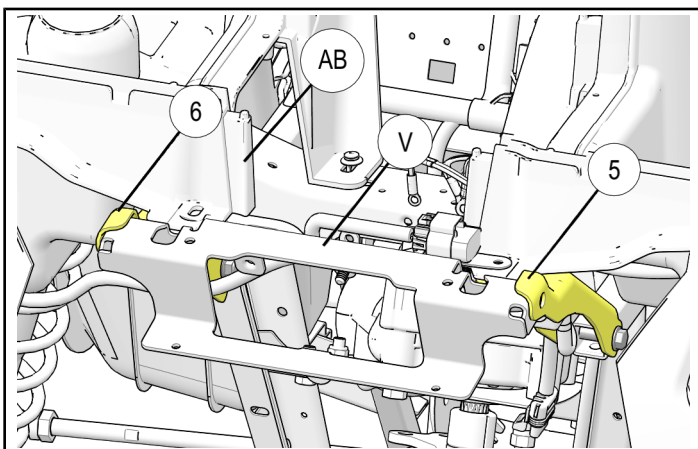
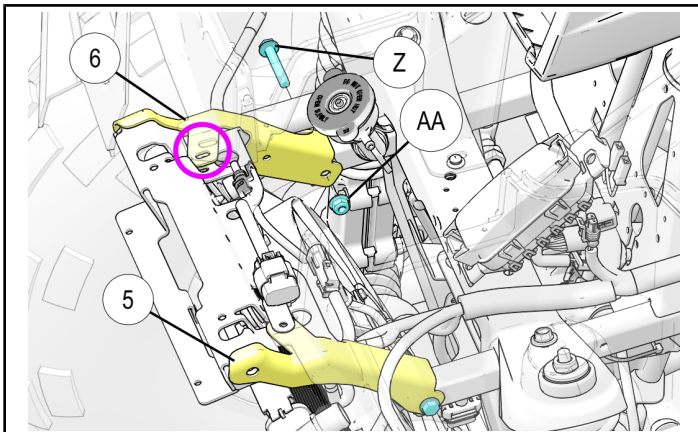

16. Install LH side lower support bracket ③ to the radiator mount with screws ⑩ ⑦ and nut ⑫ as shown. Repeat same for RH side lower support bracket ④. Torque screws ⑩ ⑦ to specifications.

TORQUE

Screws ⑩: 8 ft. lbs. (10.8 Nm)
Screws ⑦: 10 ft. lbs. (13.5 Nm)

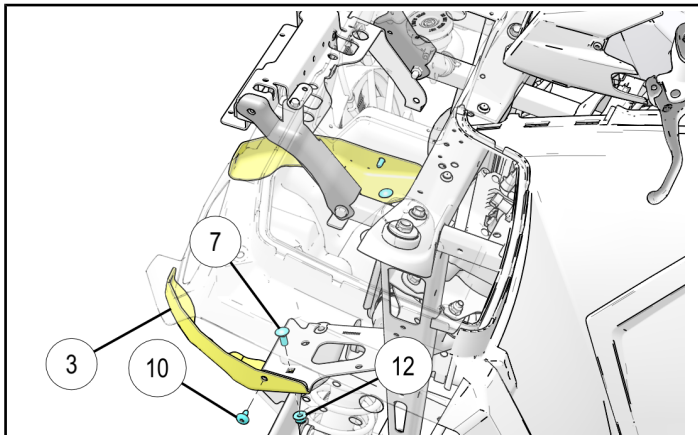

17. Install front bumper support ① to upper radiator bracket (V) by aligning holes and installing two screws ⑪ through support brackets ⑤ ⑥ as shown. Torque screws ⑪ specification.

TORQUE

8 ft. lbs. (10.8 Nm)

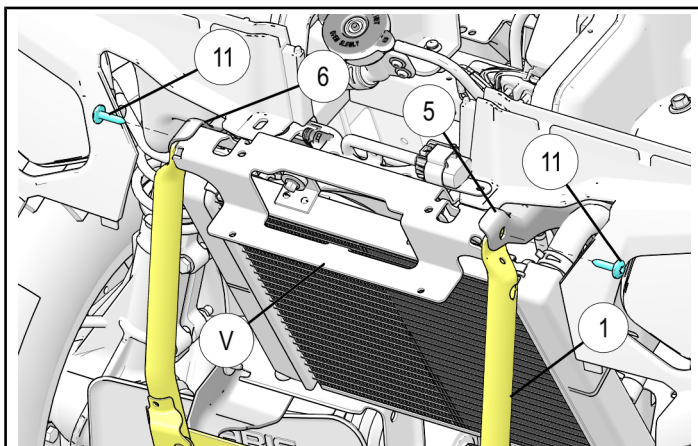

18. Install screws ⑦ and nuts ⑫ attaching bumper support ① to lower support brackets ③ ④ as shown. Torque nuts ⑫ to specification.

TORQUE

10 ft. lbs. (13.5 Nm)

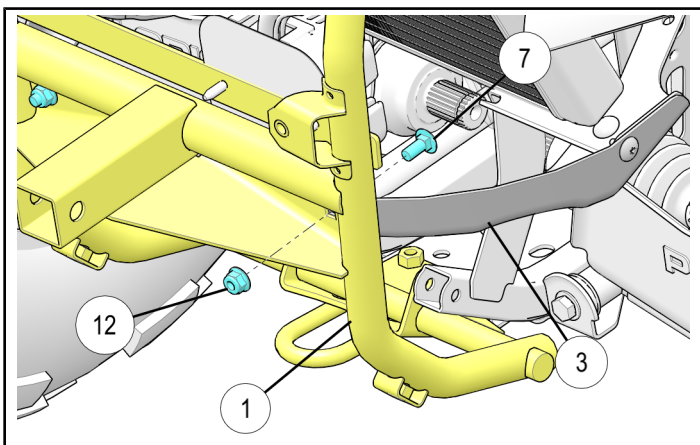

19. Reinstall bottom stock fasteners (W) (X) (Y), removed in Step 14. Torque bolts (W) (X) to specifications.

TORQUE

Bolts (W): 10 ft. lbs. (13.5 Nm)

Bolts (X): 10 ft. lbs. (13.5 Nm)

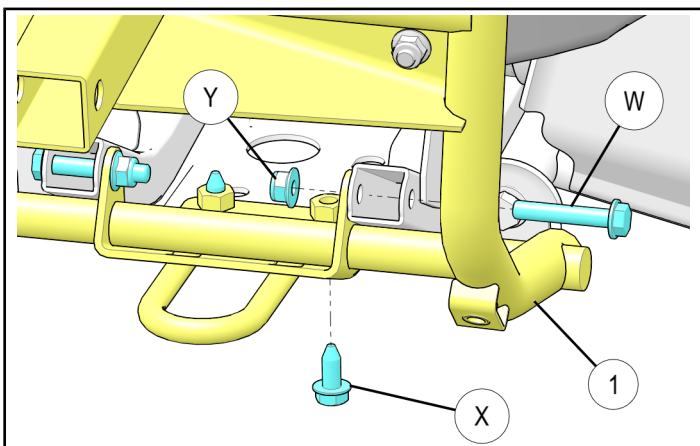

20. Reinstall regulator (S) onto the front fascia support ① using two screws (R), removed in Step 12.
21. Reinstall upper front fascia (Q) removed in Step 11.
22. Reinstall pivot bracket (H) removed in Step 8.
23. Reinstall storage access panel (F) removed in Step 7.
24. Reconnect headlights connectors (N).
25. Reinstall front rack (B) using hinge pins (E) removed in Step 6.

26. Reinstall front rack cables (D) using screws (C) removed in Step 5.

27. Close the front rack (B) and reattach rubber latches (A).

28. Install front bumper ② onto bumper support ① by aligning mounting tab holes on bumper with bumper support bracket holes and installing four screws ⑧ at and ⑨ as shown. Torque screws ⑧ ⑨ to specifications.

TORQUE

Screws ⑧: 8 ft. lbs. (10.8 Nm)

Screws ⑨: 8 ft. lbs. (10.8 Nm)

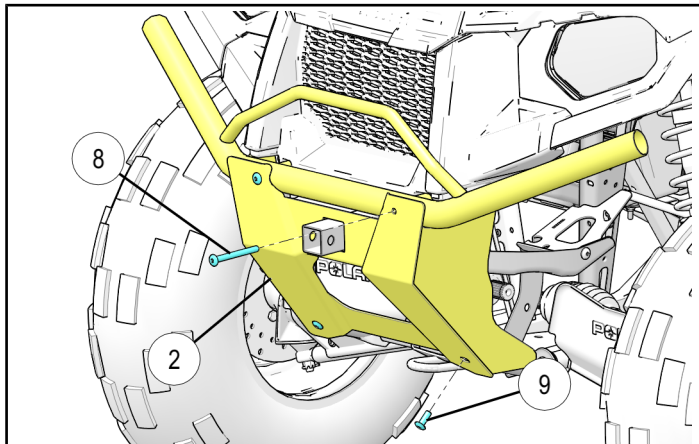
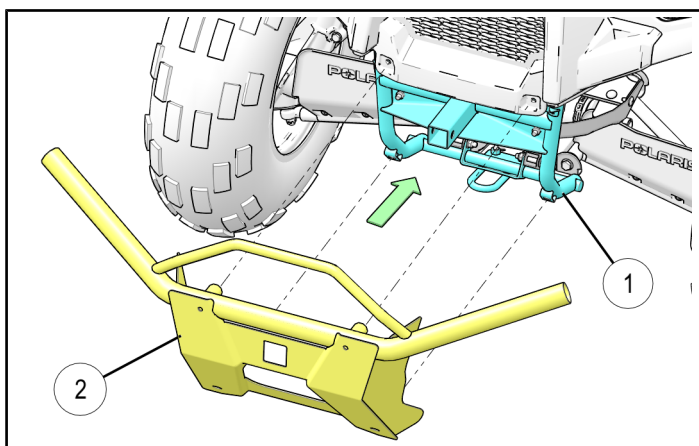

29. Reconnect the battery positive (+) and negative (-) cables to battery.

COMPATIBILITY

Front bumper kit is compatible with following accessory kit.

- Sportsman Tough Rack Kit (PN 2882321)

Front bumper kit is not compatible with following accessory kits.

- Sportsman Front Rack Extender Kit (PN 2879716)
- Other Sportsman Front Bumper Kits