

REAR BRUSH GUARD (XP) KIT

P/N 2878324

Application

2010-2011 Sportsman XP 2-Up Touring



POLARIS
The Way Out.®

Before you begin, read these instructions and check to be sure all the parts and tools are accounted for. Please retain these installation instructions for future reference and parts ordering information.

This kit includes:

Item #	Qty	Part Description	Part Number
1.....	1	Weld-Main, RR BG	1017941
2.....	1	Weld-Taillight Guard, LH	1017340
3.....	1	Weld-Taillight Guard, RH	1017341
4.....	1	Bracket-Mnt, Lower, RR, BG (MY 10)	5254627
5.....	1	Bracket-Plate, Lower, RR, BG (MY 11)	5254628
6.....	1	Bracket-Mount, Lower (MY 11)	5254366
7.....	1	Bracket-Mnt, Upper, RR, BG	5253879
8.....	2	Spacer .75" x .120" x .925"	5253880
9.....	2	M8 x 1.25 x 45 mm Carriage Bolts	-----
10.....	6	M8 x 1.25 x 20 mm Carriage Bolts	-----
11.....	4	M8 x 1.25 x 20 mm HX/FL Bolts	-----
12.....	12	M8 HX/FL Nut NYLOC	-----
	1	Instructions	9923226

Tools Required:

Metric Socket Set and/or Wrenches

IMPORTANT: For your safety, and to ensure a satisfactory installation, perform all installation steps correctly in the sequence as shown on the attached instructions.

Figure 1

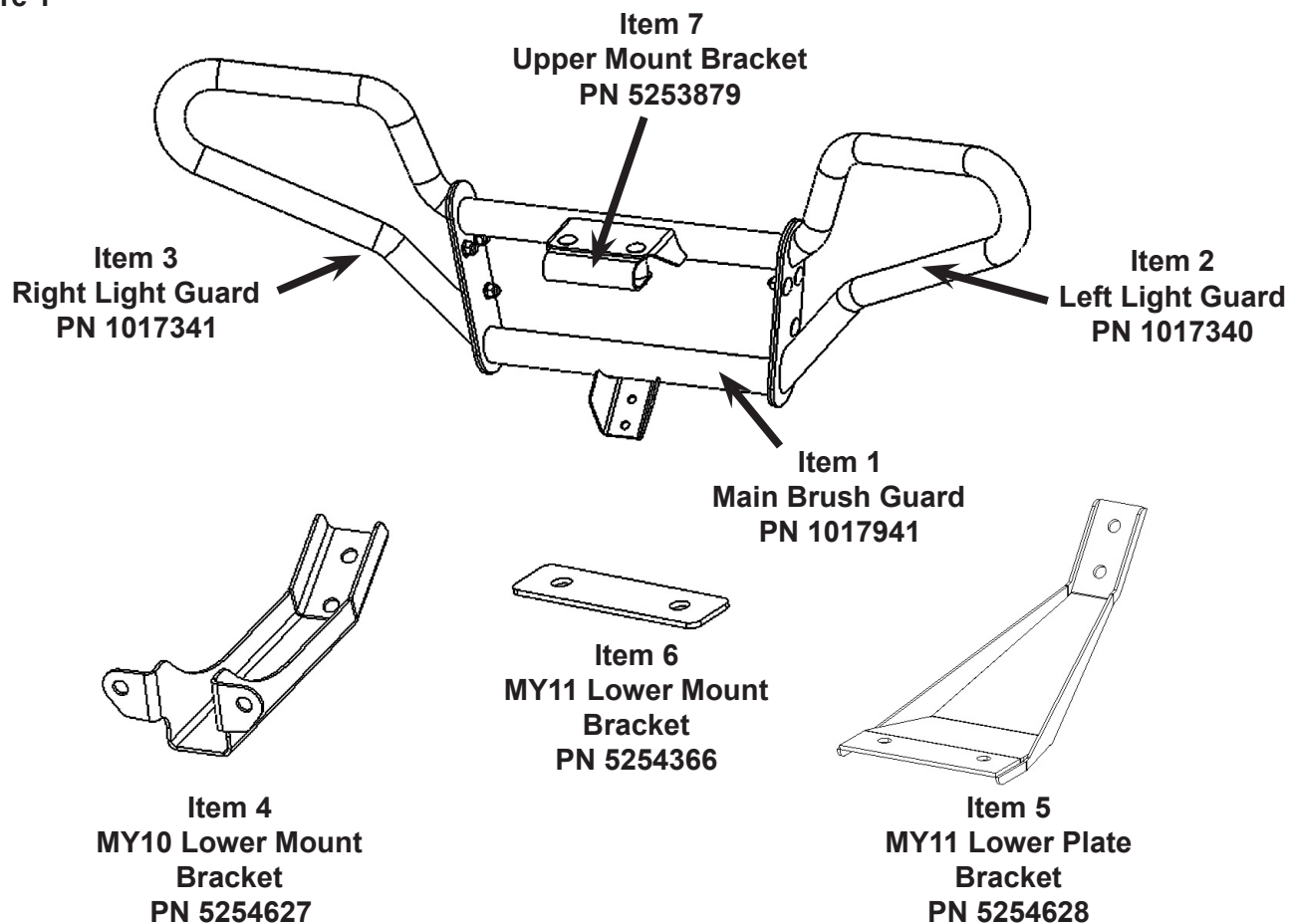

INSTALLATION INSTRUCTIONS

1. Assemble the left and right brush guard wings (Items 2 & 3) to the main brush guard body using six M8 x 1.25 x 20 mm carriage bolts and six M8 HX/FL nyloc nuts. Torque to 20 ft. lbs. (27 Nm).
2. For a MY10 vehicle, assemble the lower mount bracket (Item 4) to the main brush guard body using two M8 x 1.25 x 20 mm HX/FL bolts and two M8 HX/FL nyloc nuts. Hand-tighten only at this step.
3. For a MY11 vehicle, assemble the lower plate bracket (Item 5) to the main brush guard body using two M8 x 1.25 x 20 mm HX/FL bolts and two M8 HX/FL nyloc nuts. Hand-tighten only at this step.
4. Install the upper mount bracket (Item 7) over the rear grab bar, then attach the brush guard assembly to the upper mount bracket using two M8 x 1.25 x 45 mm carriage bolts, two spacers and two M8 HX/FL nyloc nuts. Hand-tighten only at this step.
5. Attach lower bracket (Item 4 or 5) to the lower chassis frame member below and behind the muffler. For MY10 vehicles, use two M8 x 1.25 x 20 mm HX/FL bolts and two M8 HX/FL NYLOC nuts to secure the brush guard to the vertical frame member. For MY11 vehicles, use two M8 x 1.25 x 20 mm HX/FL bolts and lower mount bracket (Item 6) to secure the brush guard to the horizontal frame member. Install fasteners from the bottom of Item 5, through the frame member, and into Item 6.
6. Torque all fasteners to 20 ft. lbs. (27 Nm) once everything is positioned correctly.
7. Re-check the torque on all bolts after 30 minutes of riding and tighten as needed.