

# REVERSE BEEPER HARNESS KIT



P/N 2880631

## APPLICATION

RANGER 570 AND RANGER ETX

## BEFORE YOU BEGIN

Read these instructions thoroughly and make sure all parts and tools are accounted for. Please retain these installation instructions for future reference and parts ordering information.

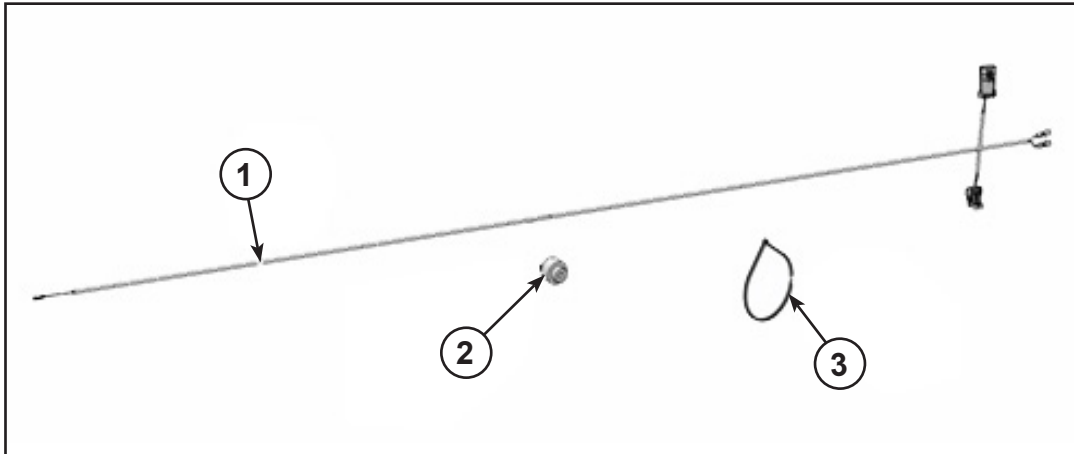

## KIT CONTENTS

Ref	Qty	Part Description	Part Number
1	1	Beeper Harness	2413030
2	1	Reverse Beeper	4011808
3	7	Panduit	7080761
	1	Instructions	9925866

## TOOLS NEEDED

Safety Glasses

## APPROXIMATE ASSEMBLY TIME

15 min

## IMPORTANT

Your Polaris REVERSE BEEPER HARNESS KIT is exclusively designed for your vehicle. Please read the installation instructions thoroughly before beginning. Installation is easier if the vehicle is clean and free of debris. For your safety, and to ensure a satisfactory installation, perform all installation steps correctly in the sequence shown.

## INSTALLATION INSTRUCTIONS

1. Place the vehicle in “**PARK**”. Lift the cargo box in upright (slant) position. Turn the key to “**OFF**” position and remove from the vehicle.
2. Remove driver’s seat. Disconnect the black negative and red positive cable from the battery.
3. Disconnect box harness (A) from chassis harness (B) and bridge the beeper harness (1) in between.

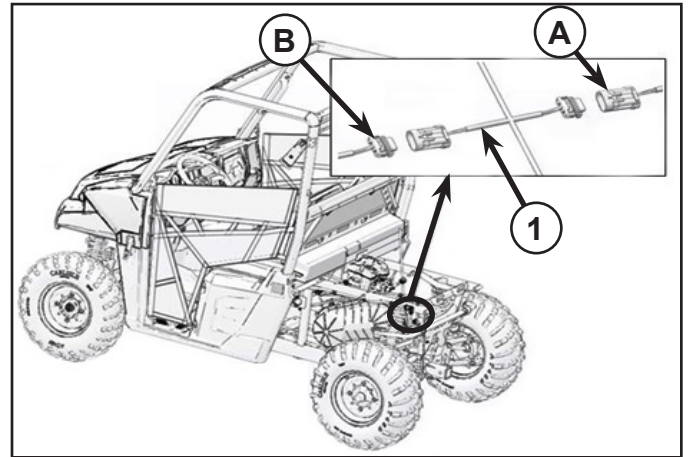

4. Route the harness along with chassis harness and connect one end of beeper harness (1) terminal to ECU. See the terminal connection procedure.

**IMPORTANT:** Tie the harness using panduit straps to avoid contact with rotating and sharp edge parts.

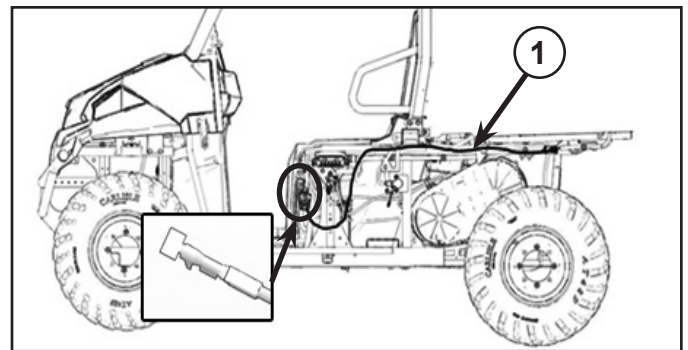

### 5. ECU Terminal Connection procedure:

- a. Unplug ECU connector (C) as shown in figure.

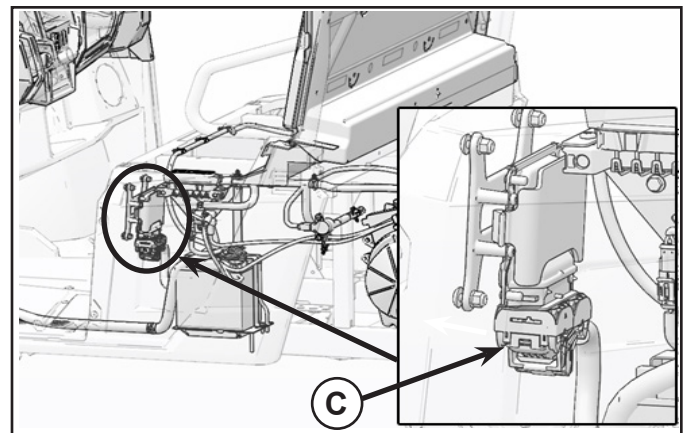

- b. Cut zip tie located on the cover of the ECU connector as shown in figure.

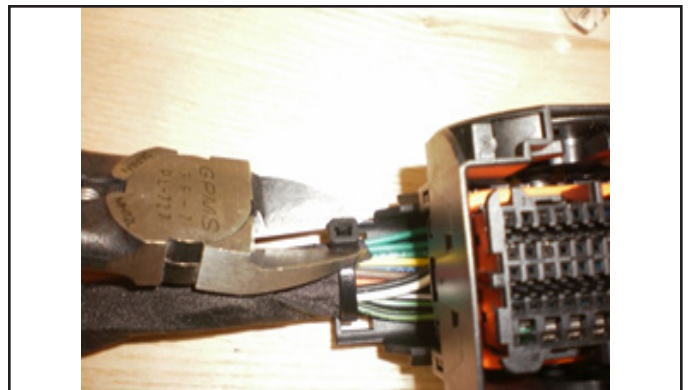

c. Remove back cover (D) as shown in figure.

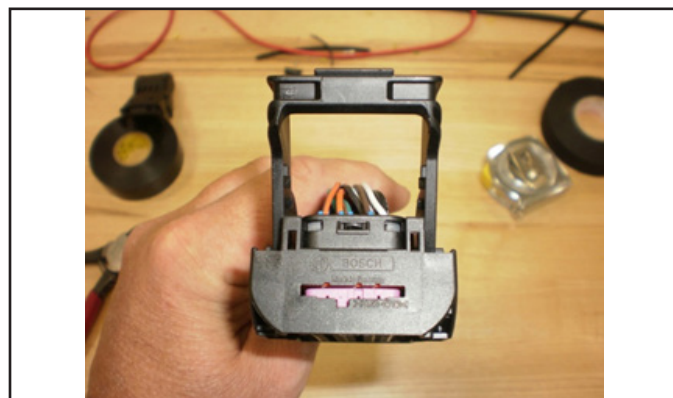
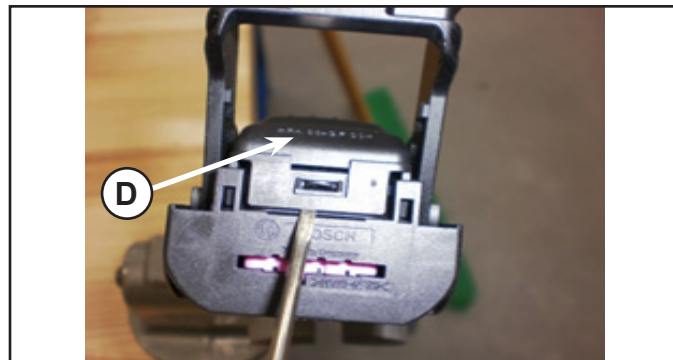

d. Remove purple TPA (push) (E) from connector as shown in figure.

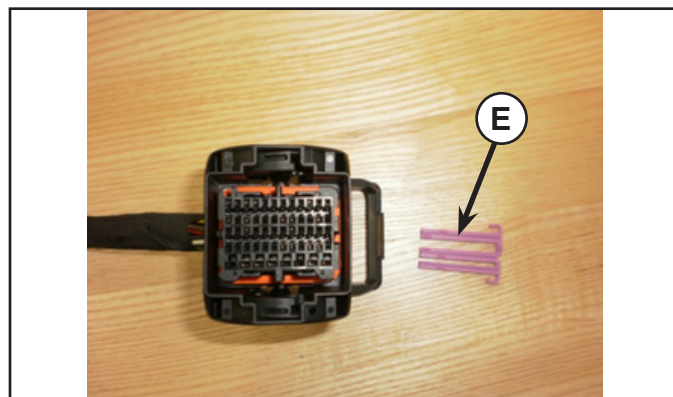

e. Locate cavity 45 on the connector and remove (pull) blue cavity plug (F).

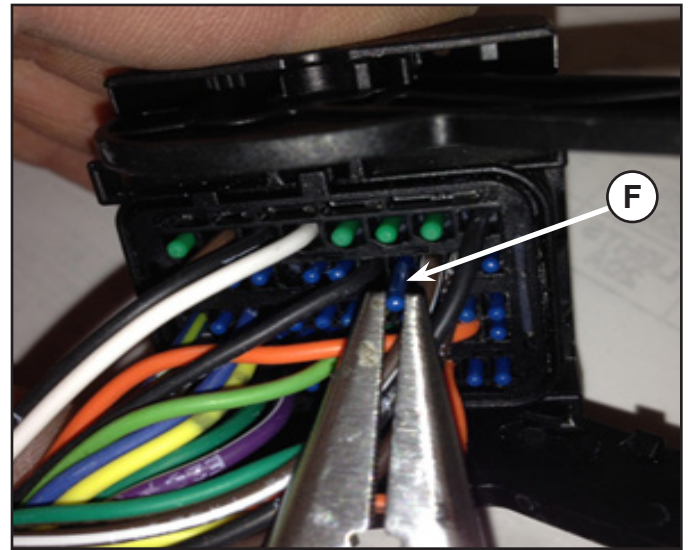

f. Insert terminal end (G) from jumper harness into cavity 45 on connector. Should easily slide in and “click” into place. Terminal will only go in one way.

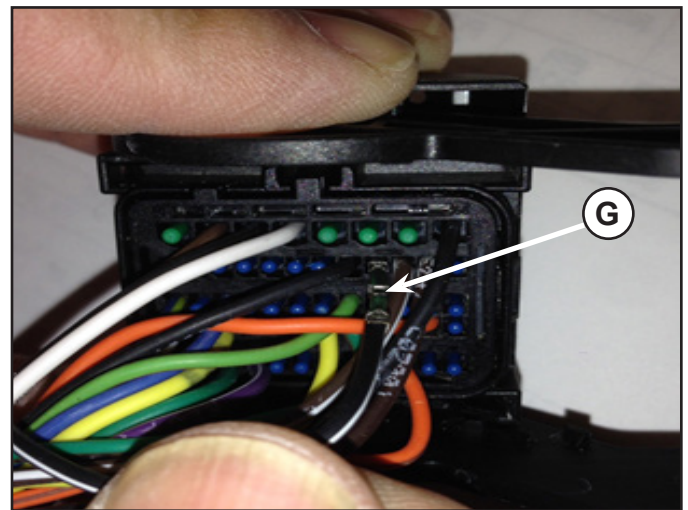

g. Insert purple TPA back into the connector making sure it seats properly. If the terminal is not pushed in all the way, the TPA will not fully seat. as shown in figure.

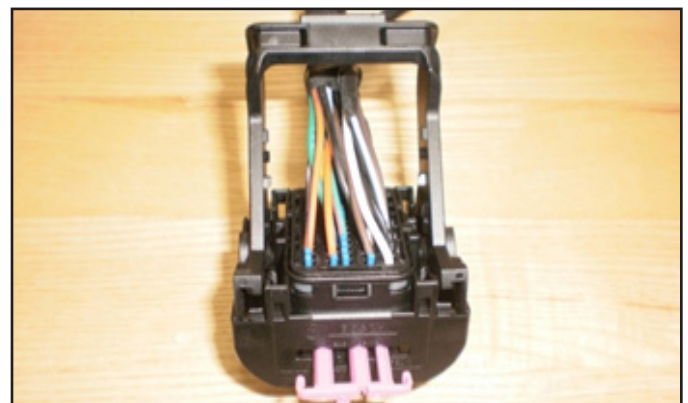

- h. Put cover on connector that removed in step 3 in this procedure.
- i. Attach Panduit strap cover to harness wire bundle.as shown in figure.
- j. Place connector back on ECU and latch that removed in step 1 in this procedure.



- 6. Connect the red/white wire to the terminal marked “+” on the beeper (2) and the purple wire to the terminal marked “-”.

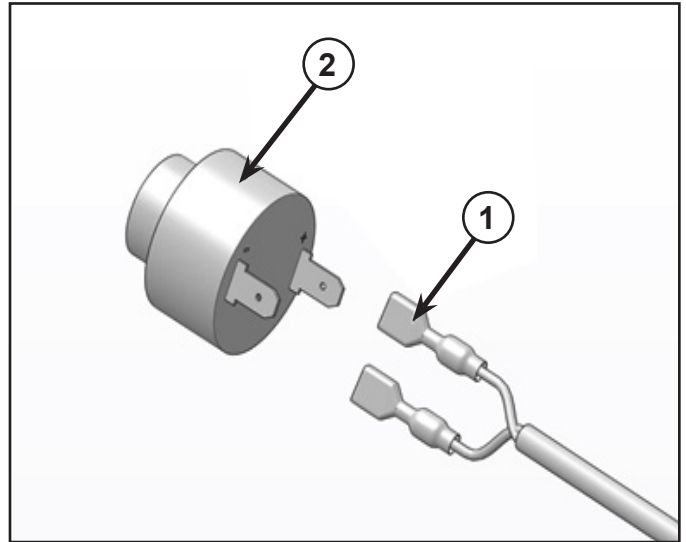

- 7. Looped the Beeper end harness cable with Beeper and tie up with chassis.
- 8. Reconnect the battery terminals and reinstall the driver’s seat.
- 9. Put down the Cargo box to the original position.
- 10. Turn “ON” key and test the functionality.