

ACCENT LIGHT KIT



P/N 2880500, 2880506, 2881119

APPLICATION

Verify accessory fitment at Polaris.com.

BEFORE YOU BEGIN

Read these instructions and check to be sure all parts and tools are accounted for. Please retain these installation instructions for future reference and parts ordering information.

KIT CONTENTS

This Kit includes:

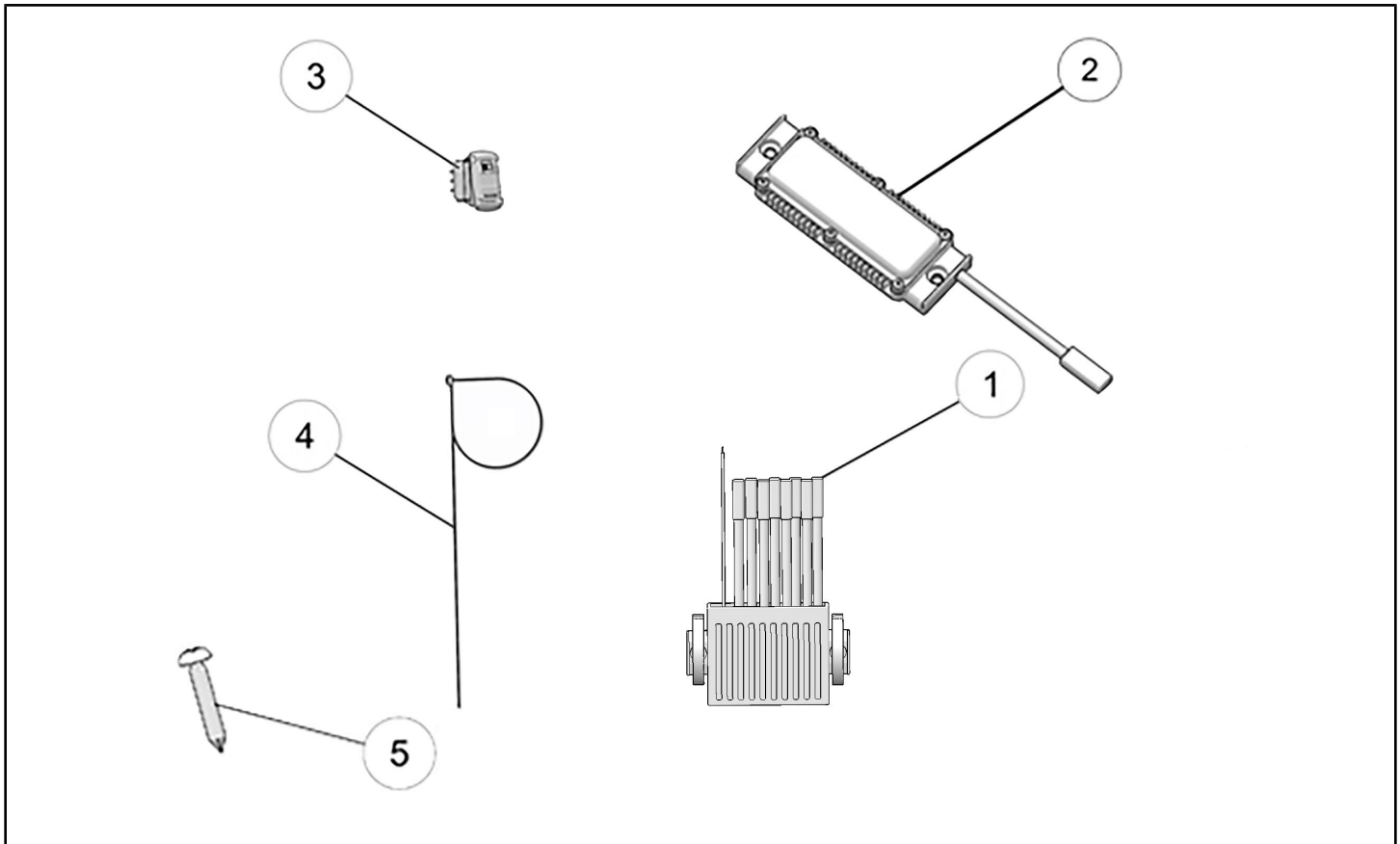

REF	QTY	PART DESCRIPTION	PART NUMBER
1	1	Electrical Box, Accent Light	2413022
2	4	Accent Light	-
3	1	Switch	4014558
4	15	Cable Tie	7080492
5	4	Screws, Self Tapping	-
	1	Instructions	9925419

TOOLS REQUIRED

- Safety Glasses
- Pliers, Push Pin
- Pliers, Side Cutting
- Screwdriver, Phillips

- Screwdriver Set, Torx®
- Utility Knife/Cutting Tool
- Wrench Set, Metric

IMPORTANT

Your ACCENT LIGHT KIT is exclusively designed for your vehicle. Please read the installation instructions thoroughly before beginning. Installation is easier if the vehicle is clean and free of debris. For your safety, and to ensure a satisfactory installation, perform all installation steps correctly in the sequence shown.

ASSEMBLY TIME

Approximately 30 minutes

INSTALLATION INSTRUCTIONS

1. Shift vehicle transmission into "PARK". Turn key to "OFF" position and remove from vehicle.
2. Gain access.
 - a. Remove driver's seat.
 - b. Remove hood (A) by twisting two knobs (B) as shown.

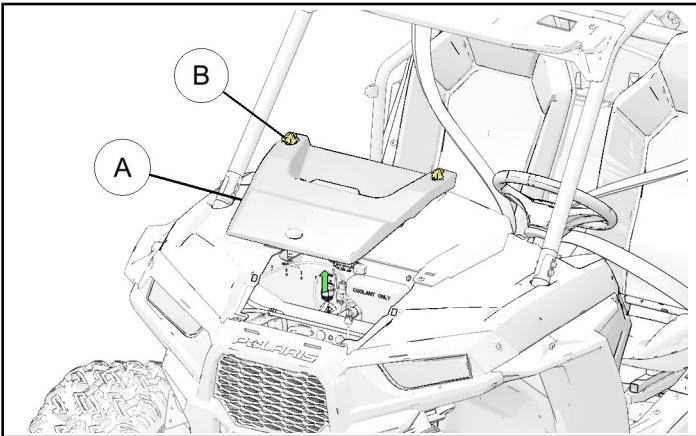

- c. Remove upper instrument panel (C) by removing two screws (D) as shown and disconnecting electrical harnesses. Retain screws.

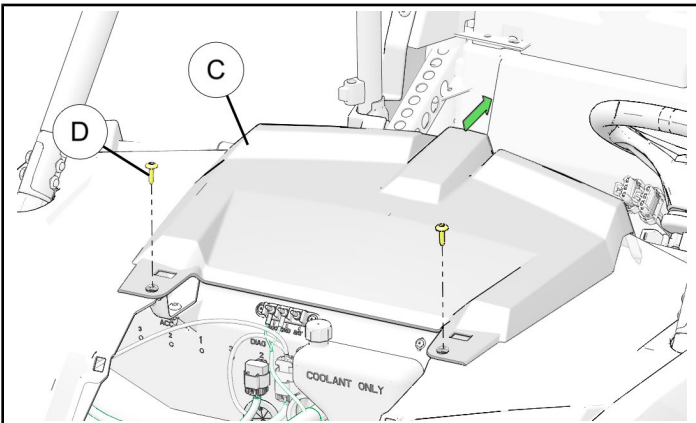

- d. Remove center console (H) by removing two screws (J) and five plastic push pins (K) as shown. Retain screws and pins.

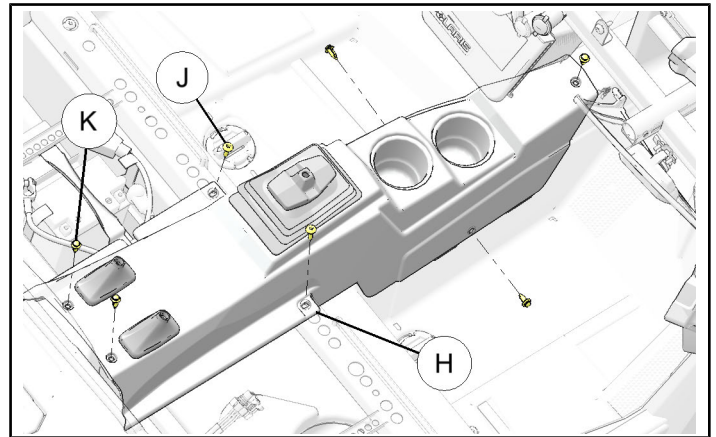

3. Disconnect black negative (-) lead from battery.
4. Install electrical box.
 - a. Install electrical box ① below driver seat as shown using two self-tapping screws ⑤.

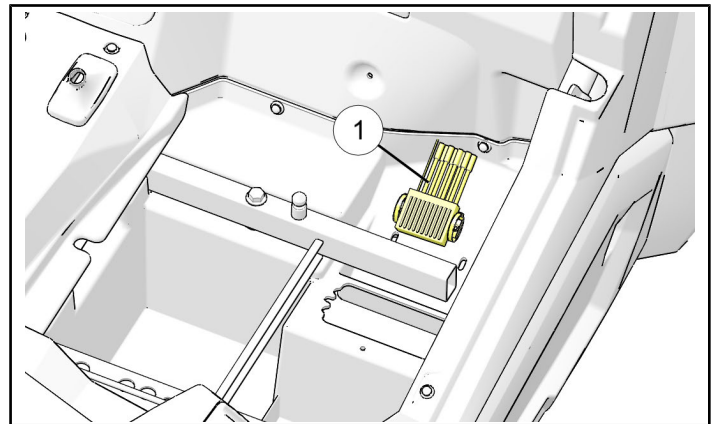

- b. Route switch and power wires forward through center console, along main vehicle harness, to upper instrument panel compartment.

5. Install switch.

- a. Cut opening (M) in upper instrument panel for light switch ③, then install switch.

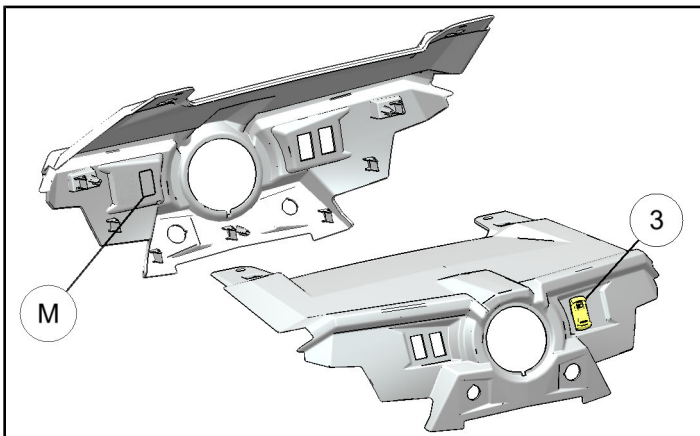

- b. Route red and black power wires (with ring terminals) through firewall grommet, then to terminal block.

NOTE

Power wires will be connected to terminal block in Step 9.

- c. Secure wiring from electrical box to switch to terminal block as required using cable ties ④ to prevent chafing against sharp edges or moving parts.

6. Install FRONT lights.

- a. Install accent light ② to vehicle frame using one cable tie ④ at each end of light as shown.

NOTE

RZR 900/S 900 RH side shown; LH side similar.
RZR XP 1000 similar.

- b. Route light harness up and across frame to vehicle centerline, then down towards main vehicle harness as shown.

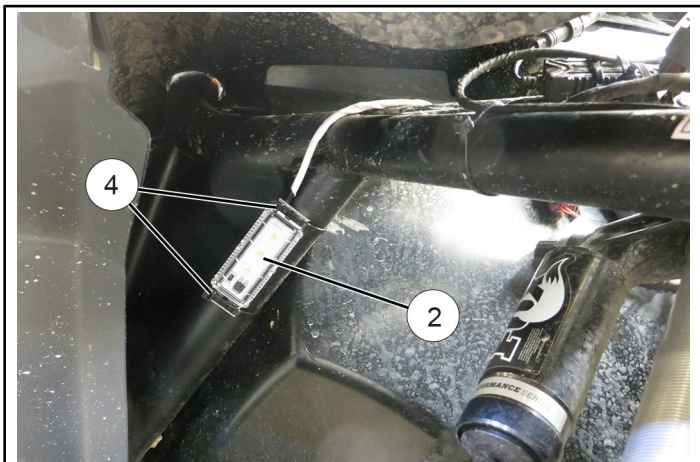

- c. Route light harness down along main vehicle harness into center console as shown, then rearward to electrical box ①.

NOTE

View looking inboard from LH wheel well.

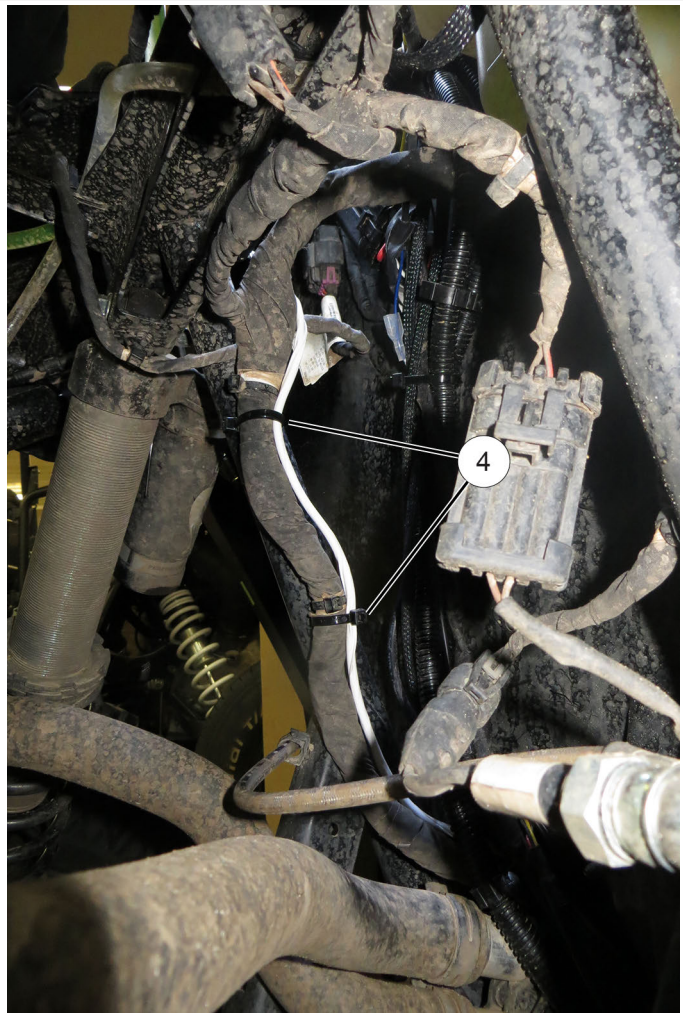

- d. Repeat Steps a. through c. for LH side.
- e. Secure harness as previously shown using cable ties ④ to prevent contact with hot surfaces, or chafing against sharp edges or moving parts.

- 7. Install REAR lights.

RZR 900 and RZR S 900:

- a. Install accent light ② to vehicle frame using one cable tie ④ at each end of light as shown.

NOTE

RH side shown; LH side similar.

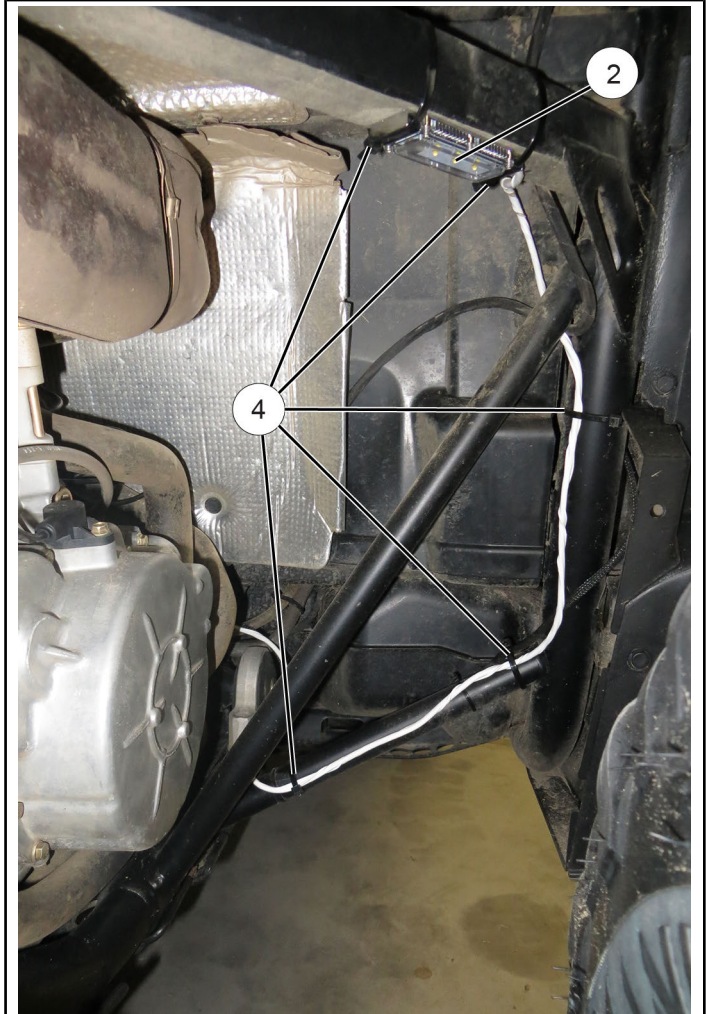

- b. Route light harness down and across frame to main vehicle harness as shown above, then forward into center console and electrical box ①.
- c. Repeat Steps a. and b. for LH side.
- d. Secure harness as previously shown using cable ties ④ to prevent contact with hot surfaces, or chafing against sharp edges or moving parts.

RZR 1000 and RZR XP 1000:

- a. Install accent light ② to vehicle frame using one cable tie ④ at each end of light as shown.

NOTE

RH side shown; LH side similar.

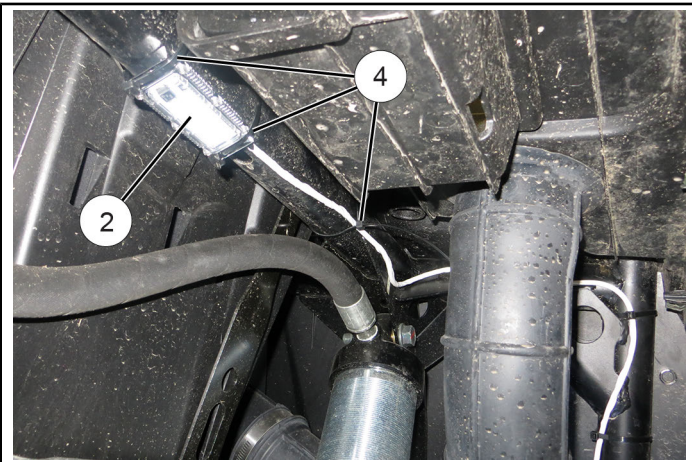

- b. Route light harness down and across frame as shown.



- c. Route light harness across to vehicle centerline and forward into center console as shown, then to electrical box ①.

NOTE

View looking inboard from LH wheel well.

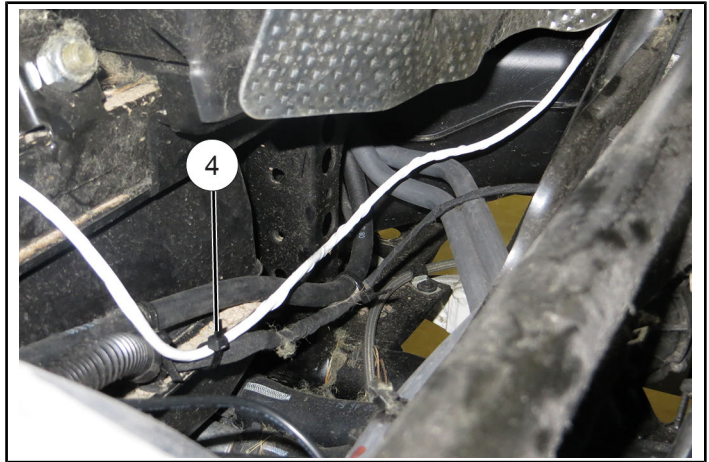

- d. Repeat Steps a. through c. for LH side.
e. Secure harness as previously shown using cable ties ④ to prevent contact with hot surfaces, or chafing against sharp edges or moving parts.

8. Connect light harnesses to electrical box ①.
 - a. Left front light
 - b. Right front light
 - c. Switch
 - d. Left rear light
 - e. Right rear light
 - f. Terminal block

9. Connect power wires to terminal block.
 - Red wire to terminal post with existing red wire (unswitched 12V POS)
 - Black wire to terminal post with existing black wire (12V NEG)

NOTE

Electrical box accommodates up to eight accent light connections; any four may be used for this kit installation. Additional accent lights available (sold separately).

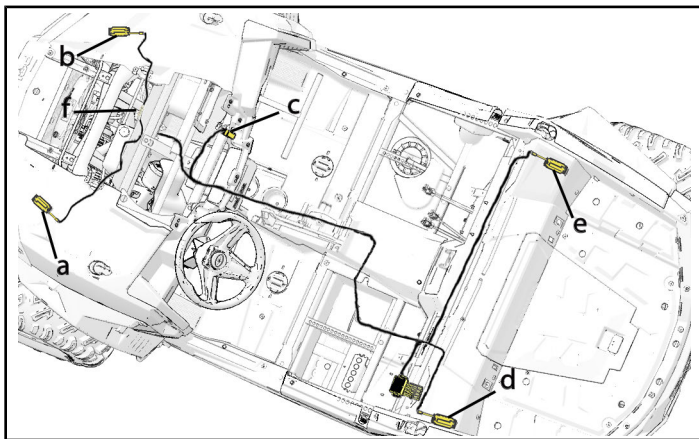
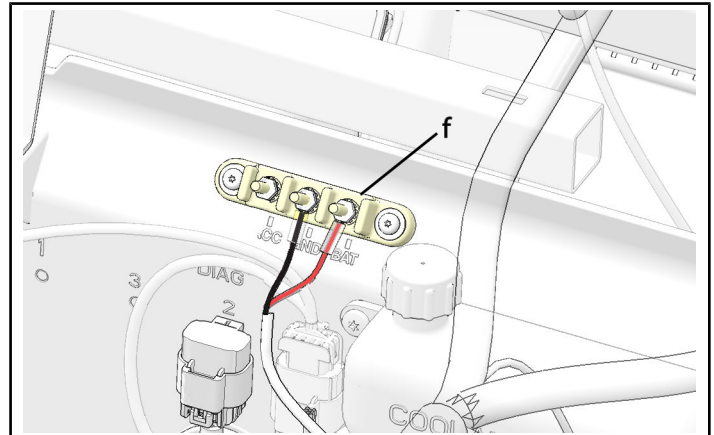

10. Reconnect black negative (-) lead to battery.
11. Restore access.

