

POLARIS® PRO HD 4500 WINCH KIT



P/N 2882238

APPLICATION

Verify accessory fitment at Polaris.com.

NOTE

You must order below mentioned power cables kit separately to connect battery to the vehicle bus bar.

- For 3 Seat Models : PN 2881684
- For Crew Models : PN 2881685

BEFORE YOU BEGIN

Read these instructions and check to be sure all parts and tools are accounted for. Please retain these installation instructions for future reference and parts ordering information.

KIT CONTENTS

This Kit includes:

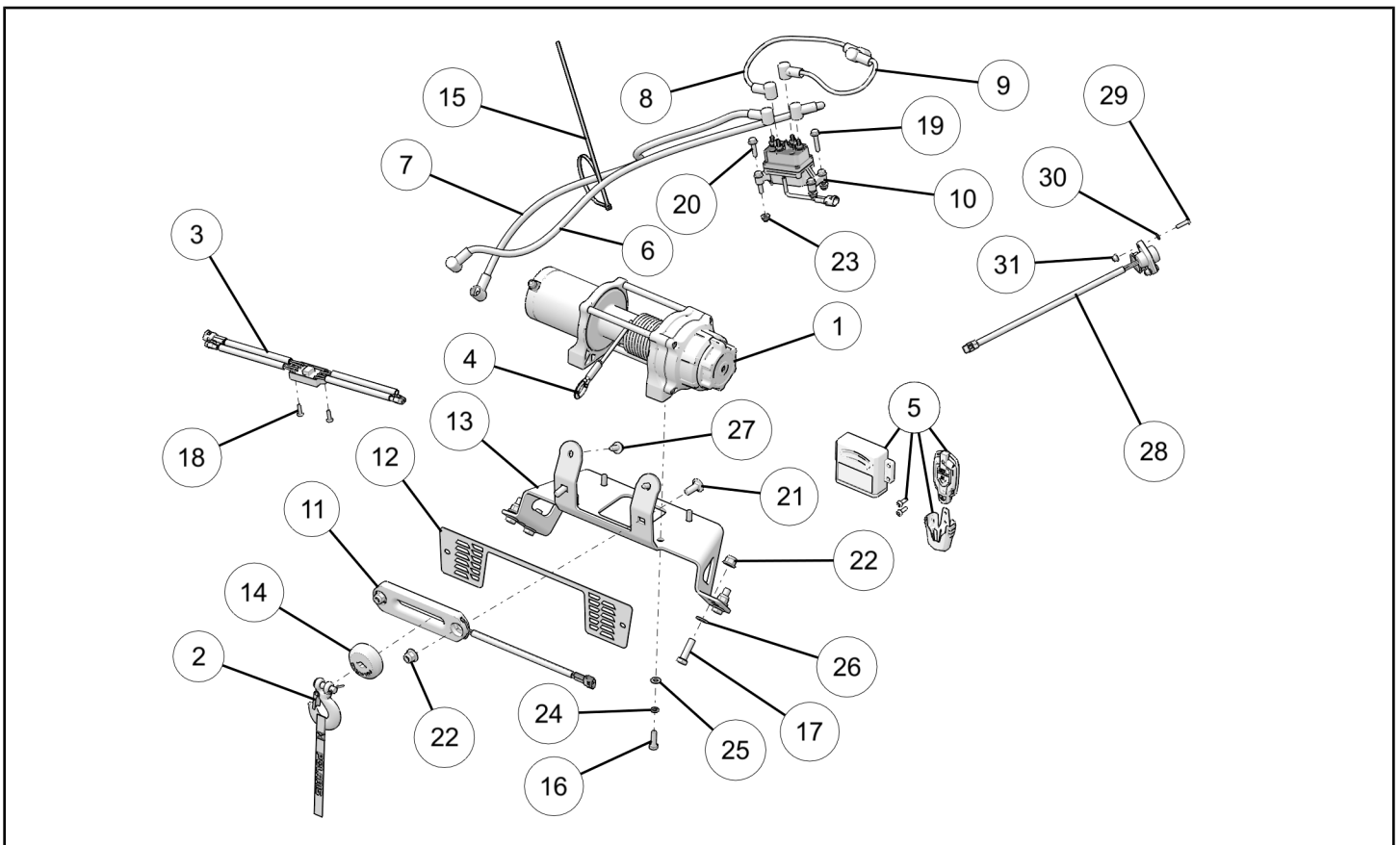

REF	QTY	PART DESCRIPTION	PART NUMBER
1	1	Winch Assembly, 4500 HDDS	2206384
2	1	Latch Hook	2411836
3	1	Control box	**
4	1	Rope	2879187

REF	QTY	PART DESCRIPTION	PART NUMBER
5	1	Wireless Remote Kit	2879316
6	1	Winch Cable, Yellow 6 GA	4013468-740
7	1	Winch Cable, Blue 6 GA	4013469-740
8	1	Power Cable, Black	4013470-480
9	1	Power Cable, Red	4013471-480
10	1	Contactora	4015095
11	1	Autostop Fairlead	**
12	1	Grill, Fairlead Cover	5255409
13	1	Winch Mount Bracket	-
14	1	Rubber Stop Magnet	**
15	10	Panduit Strap	7080492
16*	4	Screw Hex Head - M8 X 1.25 X 25	-
17*	4	Screw Hex Head - M10 X 1.5 X 35	-
18*	2	Screw - 10 X 5/8	-
19*	4	Screw Hex Head - M6 X 1.0 X 30	-
20*	4	Screw - M6 X 1.0 X 25	-
21*	2	Screw - M10 X 1.5 X 25	-
22*	6	Nut - M10 X 1.5	-
23*	4	Nut Hex Flange - M6 X 1.0	-
24*	4	Washer - M8 X 12.7	-
25*	4	Washer - 0.62 X 0.330 X 0.060	-
26*	4	Washer - 10.5 X 20 X 2.0	-
27*	2	Screw - 5/16" - 18 X 1.25	-
	1	Winching Guide	9923644
	1	Instructions	9927471
		Internal Cam Service Kit (includes internal cam for freespool handle to connect winch to a replaceable handle, purchase handle separately)	2205497
		Service Handle (includes freespool handle and screw)	2205265

Items marked (*) are included in Hardware Kit (PN 2878894).

Items marked (**) are included in Kit (PN 2881288).

Power Cable Kit (PN 2881684) Includes:

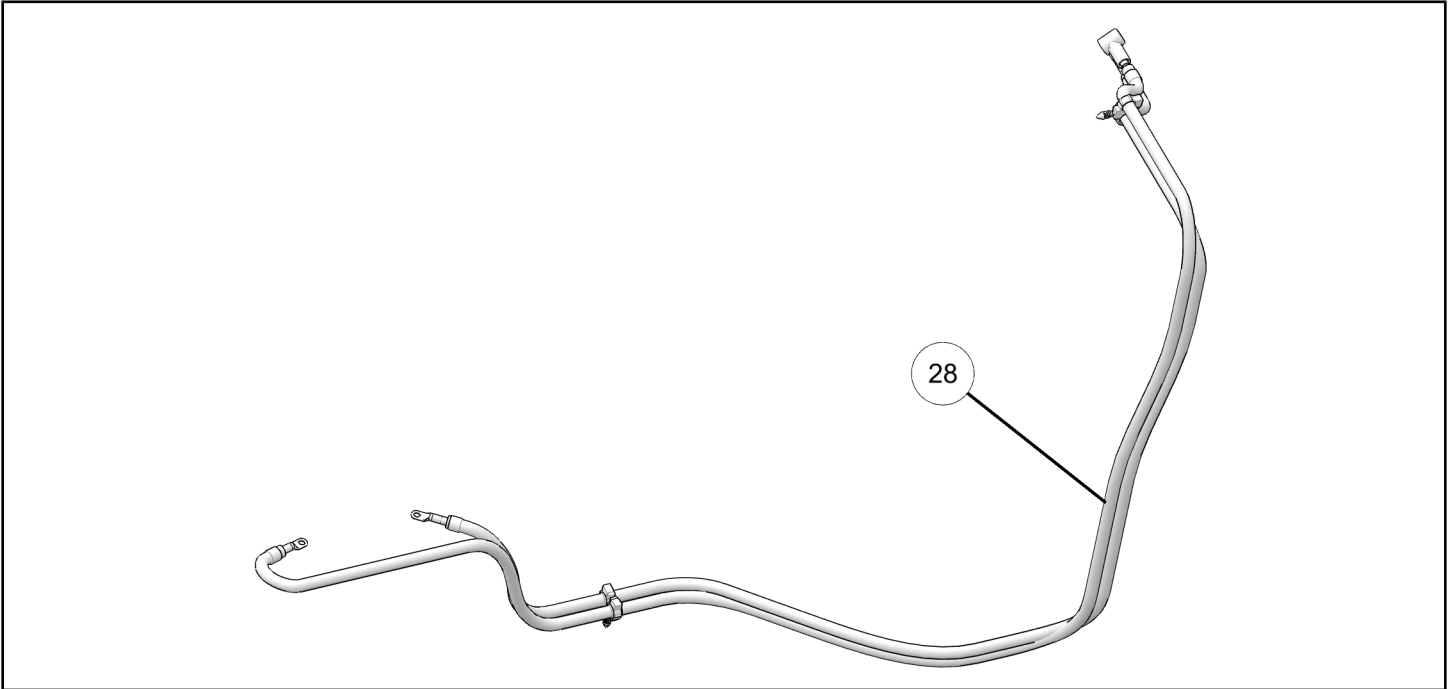

REF	QTY	PART DESCRIPTION	PART NUMBER
28	1	Power Cables, Vehicle Bus Bar to Battery	4015881
	1	Instructions	9926841

TOOLS REQUIRED

- Safety Glasses
- Socket Set, SAE
- Socket Set, Metric
- Wrench Set, SAE
- Wrench Set, Metric
- Phillips Screwdriver
- Socket Set, Torx® Bit
- Pliers, Side Cutting

IMPORTANT

Your POLARIS® PRO HD 4500 WINCH KIT is exclusively designed for your vehicle. Please read the installation instructions thoroughly before beginning. Installation is easier if the vehicle is clean and free of debris. For your safety, and to ensure a satisfactory installation, perform all installation steps correctly in the sequence shown.

ASSEMBLY TIME

Approximately 1 hr.

INSTALLATION INSTRUCTIONS

PREPARATION

1. Shift vehicle transmission into "PARK". Turn key to "OFF" position and remove from vehicle.
2. Remove the driver seat and disconnect black negative cable first and then red positive cable from the battery.
3. Remove the front bumper (A) by removing seven bolts (B).

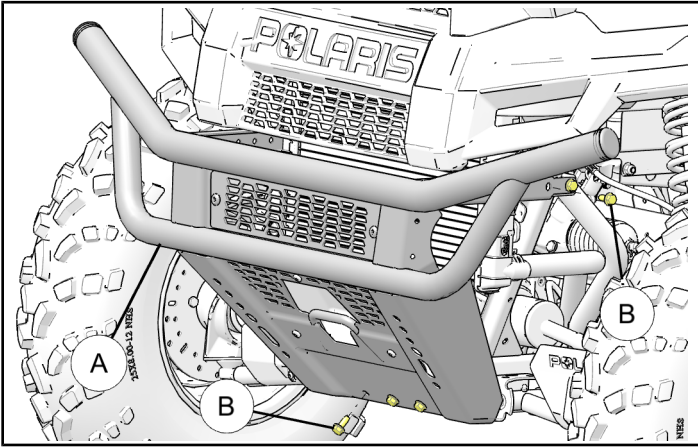

4. Remove grill screen (C) from bumper by removing two screws (D). Retain screws for reuse.

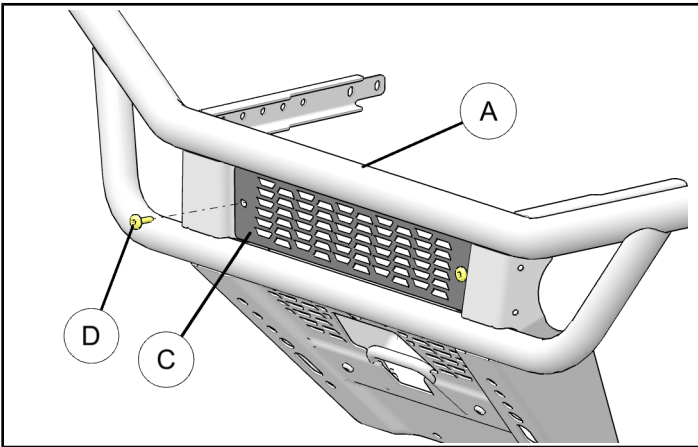

5. Detach rubber latch (F) on both sides of vehicle and open the hood (E).

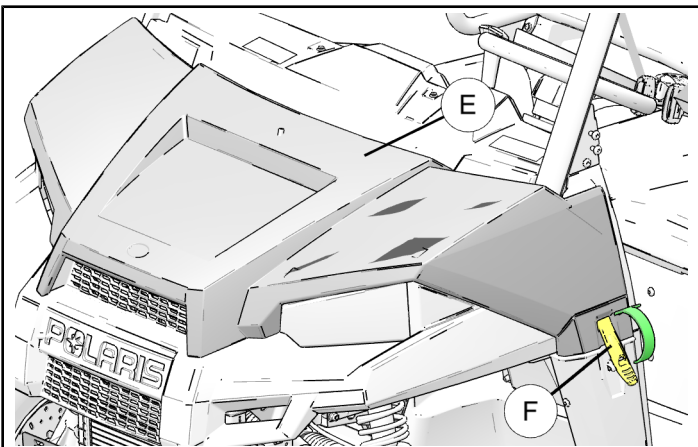

6. Remove seven screws (G) securing drive shaft cover (H) to the floor. Save fasteners for use during reinstallation. Remove drive shaft cover (H) from vehicle.

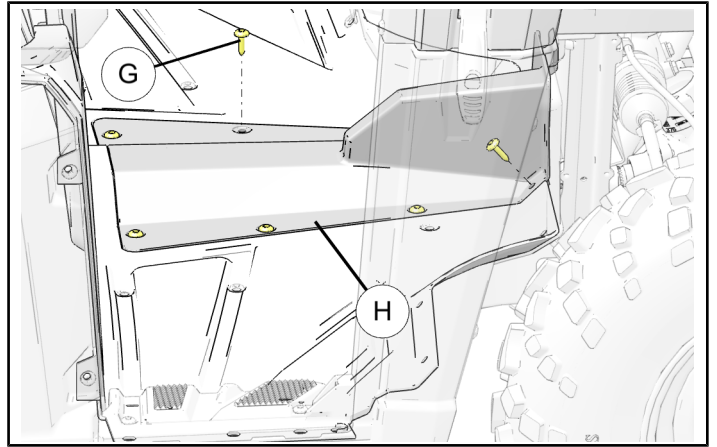

POWER CABLE KIT (PN 2881684) INSTALLATION

1. Route power kit cables (red and black) (28) from battery to bus bar terminals following the vehicle main wire harness as shown. Do not connect cables to battery and bus bar terminals at this time.

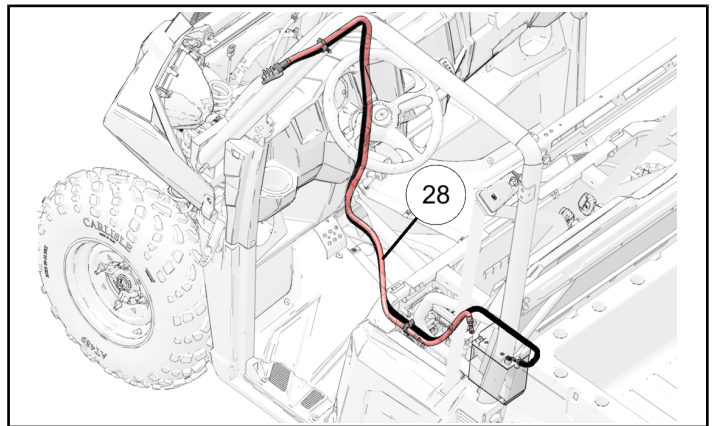

2. Install red and black power cables kit (28) to vehicle bus bar as shown.

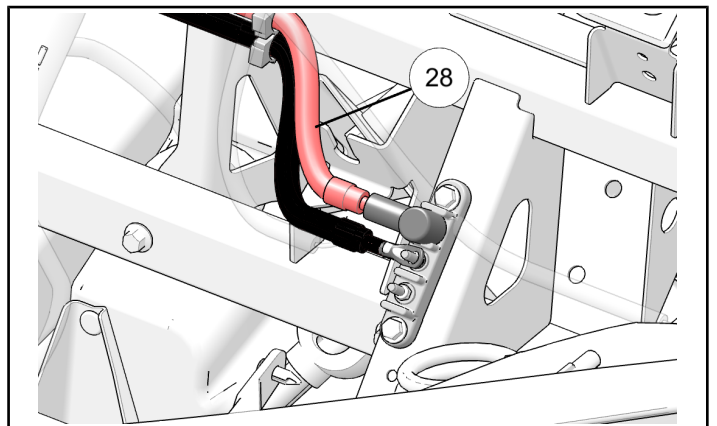

CONTACTOR INSTALLATION

1. Install contactor ⑩ to center frame member under hood using two screws ⑲ as shown. Tighten just until snug. Do not overtighten.

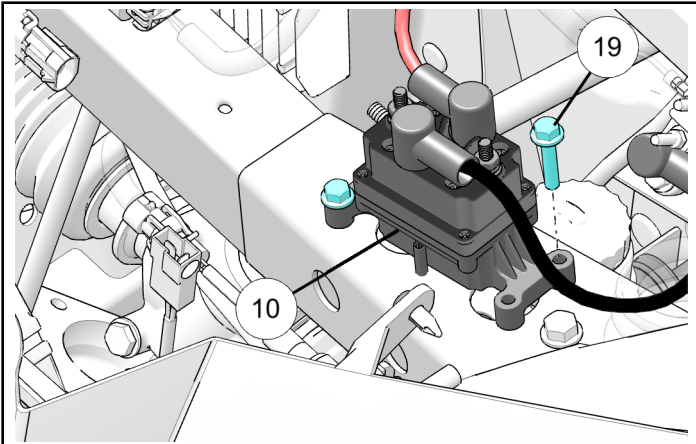

2. Connect short (250mm) red ⑧ and black ⑨ cables to the vehicle bus bar as shown. Connect the other ends of cables to their respective colored posts on contactor and torque to specification. Slide the cable covers on as shown.

TORQUE

4ft. lbs. (5.4 Nm)

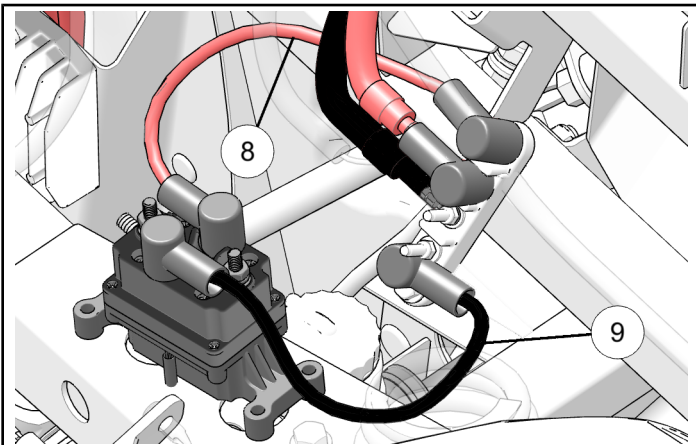

WINCH INSTALLATION

1. Install winch mounting bracket ⑬ onto the front bumper ① using four screws ⑰, nuts ⑳, and washers ㉖ on lower side and two self-tapping screws ㉗ at the top as shown. Tighten bolts and nuts to specification, but tighten self-tapping screws just until snug.

TORQUE

20ft. lbs. (27.1 Nm)

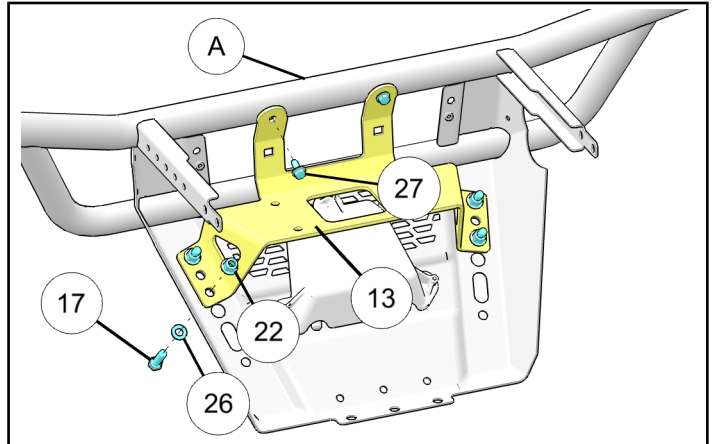

2. Install new grill screen ⑫ on front bumper ① using retained two screws ㉔.

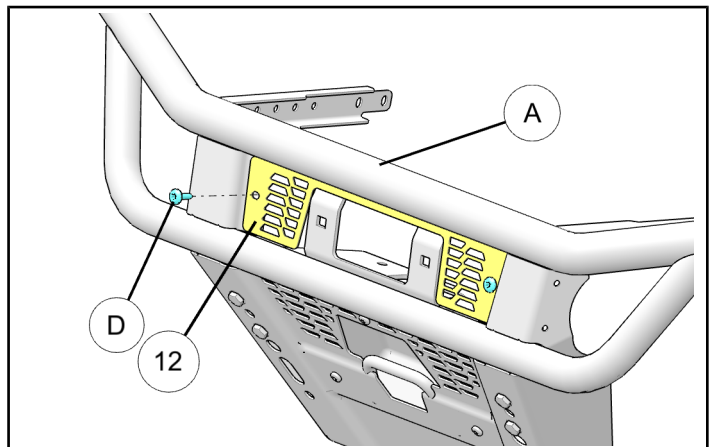

3. Install auto stop fairlead ⑪ to winch mounting bracket ⑬ using two screws ㉑ and nuts ㉒ and torque to specification.

TORQUE

16ft. lbs. (21.7 Nm)

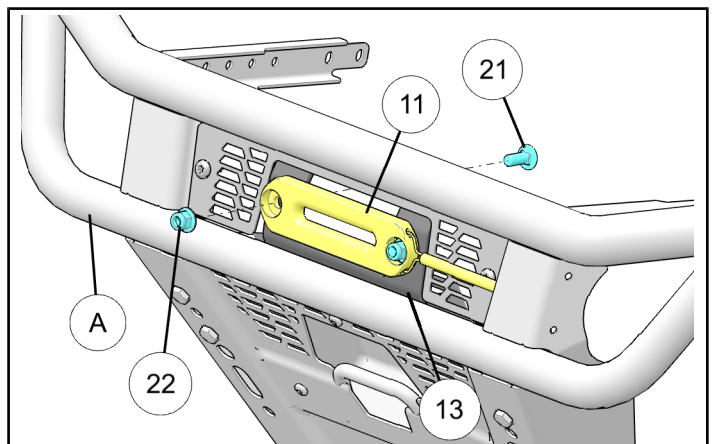

4. Install winch ① onto the winch mounting bracket using four screws ⑯, split washers ⑳, and flat washers ㉑ as shown and torque to specification.

TORQUE

20ft. lbs. (27.1 Nm)

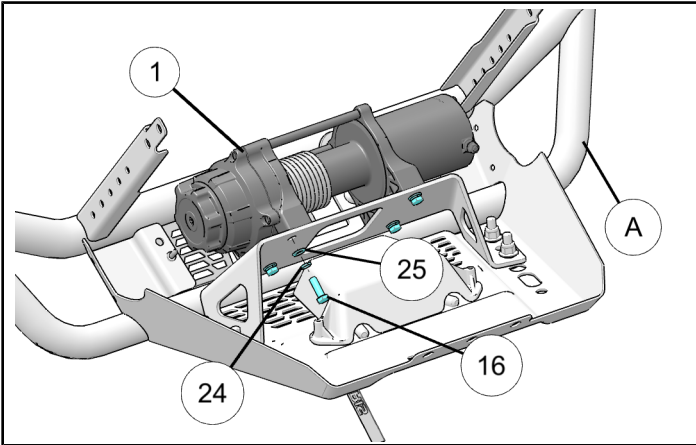

5. Insert winch rope ④ through autostop fairlead ⑪ and rubber stopper ⑭ as shown. Install hook ② onto the rope using clevis and cotter pins. **HINT:** Attach a plastic cable tie to the end of the rope and feed the cable tie through the rubber stop. Use a little wax or other mild lubricant on the rubber stop and pull the rope through the rubber stop using the plastic cable tie.

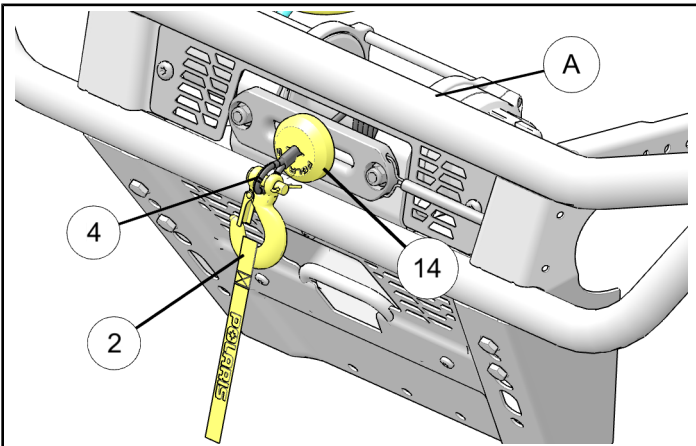

6. Reinstall bumper assembly ① onto the vehicle using seven retained screws ②.

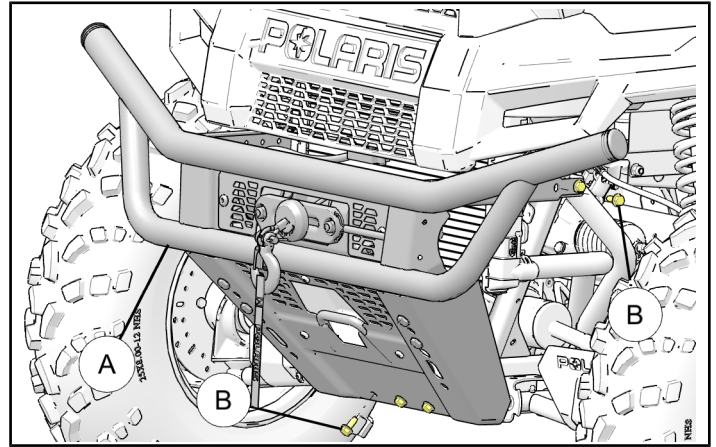

7. Connect yellow ⑥ and blue ⑦ cables to the corresponding posts on winch assembly. Route cables from winch assembly to the contactor posts as shown and torque nuts to specification.

TORQUE

4ft. lbs. (5.4 Nm)

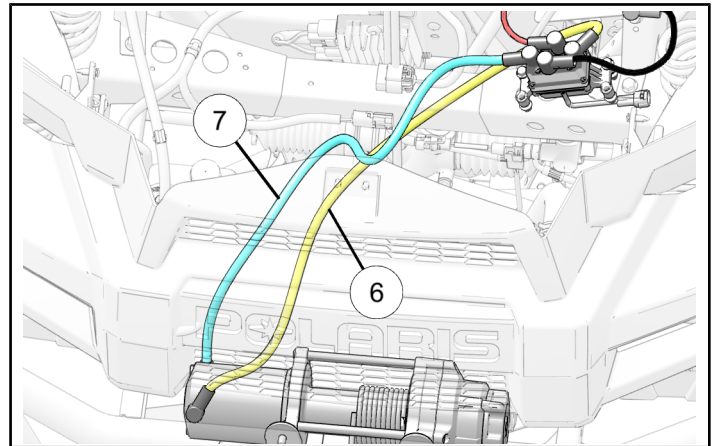

8. Connect blue ⑦ and yellow ⑥ cables to contactor posts as shown and torque to specification.

TORQUE

4ft. lbs. (5.4 Nm)

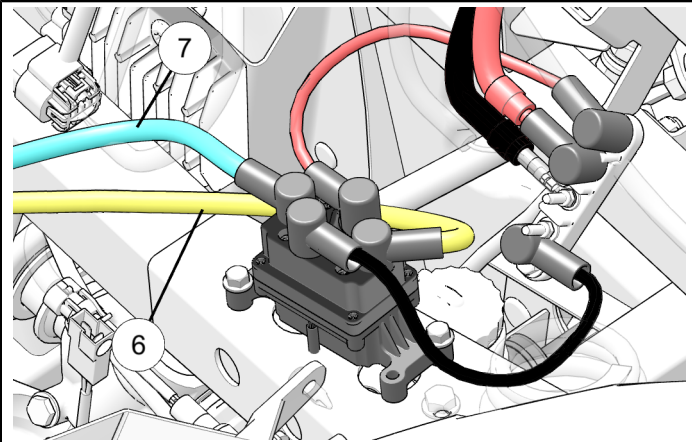

CONTROL BOX INSTALLATION

1. Position control as shown behind the radiator and fasten to chassis with supplied cable ties as shown. Connect white electrical connectors for the control box as seen in the top photo of the Electrical Connections Reference Guide section of your instructions.

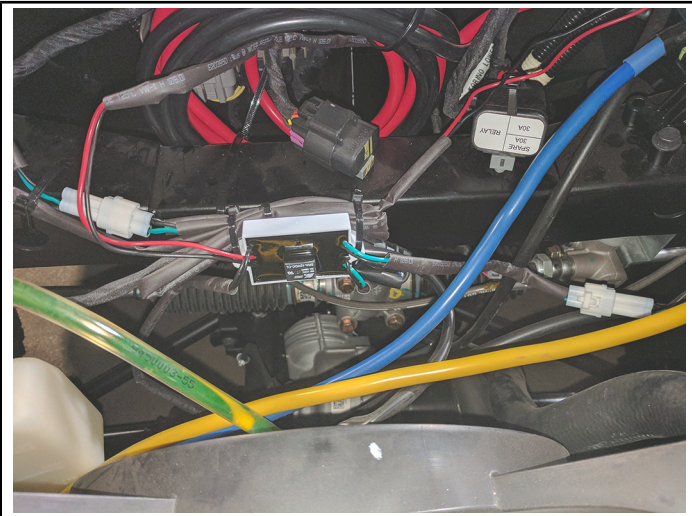

2. Route power wires from control box to bus bar and connect red positive (+) (or orange depending on the date your accessory kit was built) power wire from control box to orange, keyed power terminal on the vehicles bus bar. Route black negative (-) wires from control box ② to black (ground) terminal area on bus bar.
3. Secure all remaining wires to the to the vehicle at this time using supplied cable ties.

WIRELESS REMOTE RECEIVER INSTALLATION

1. Mount wireless remote receiver onto chassis using supplied screws as shown. Tighten screws until snug. Do not overtighten.

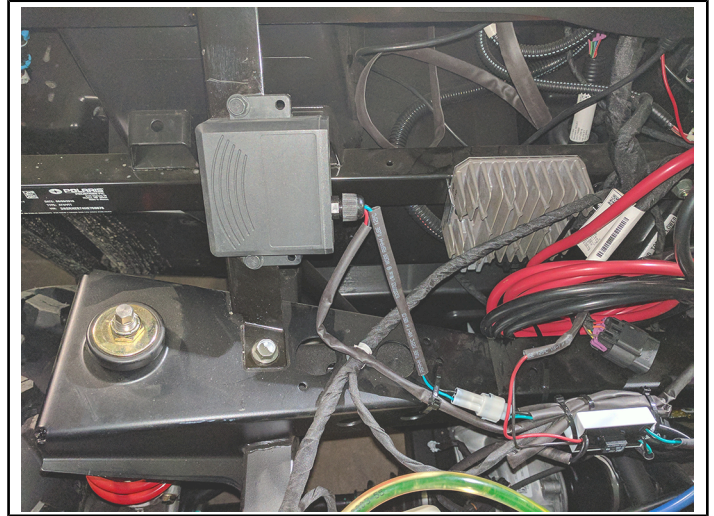

2. Connect white electrical connectors from remote receiver as seen in the top photo of the Electrical Connections Reference Guide of the instruction manual. Route remote receiver power wires to bus bar area and connect red positive (+) power wire to the keyed power terminal as shown and the black negative (-) cable to the ground terminal.
3. Secure remaining power wires to bus bar using existing fasteners.
4. Secure all remaining wires to vehicle main wire harness using cable ties.

WIRELESS REMOTE HOLDER INSTALLATION

1. Wireless remote holder can be installed in desired location on vehicle. See photo for possible mounting location. Use screws supplied in the wireless remote kit for holder installation.



FINAL INSPECTION

1. Confirm that all wiring is correct.
2. Confirm that there are no exposed wires or terminals.
3. All loose wires need to be secured away from moving parts and heat sources.

REINSTALLATION

1. Re-connect the main vehicle battery cables and cables from power cable kit ⑳ to battery terminals using original hardware.
2. Reinstall drive shaft cover ㉑ using retained screws ㉒.
3. Reinstall the hood ㉓ onto the vehicle.
4. Reinstall driver seat onto the vehicle.

WIRELESS REMOTE OPERATION

- When properly installed, the wireless remote will allow you to operate the winch from off the vehicle, which can be a safe way to operate the winch when done properly.
- To use the wireless remote, hold the small "On/Off" button for three seconds or until the LED light on the remote turns on. If the vehicle is on so that the winch is receiving power, the wireless remote should operate the winch as if you were using the winch switch ① located on the handlebar. If the remote is not operating properly, see the troubleshooting information at the end of the instructions.
- The remote will automatically turn itself off after 30 seconds of inactivity. You will therefore need to turn the remote back on if it has been more than 30 seconds since prior use.
- To manually turn off the remote, hold the small "On/Off" button for 3 seconds or until the LED light turns off.

- See the illustration below for proper wireless remote operation.

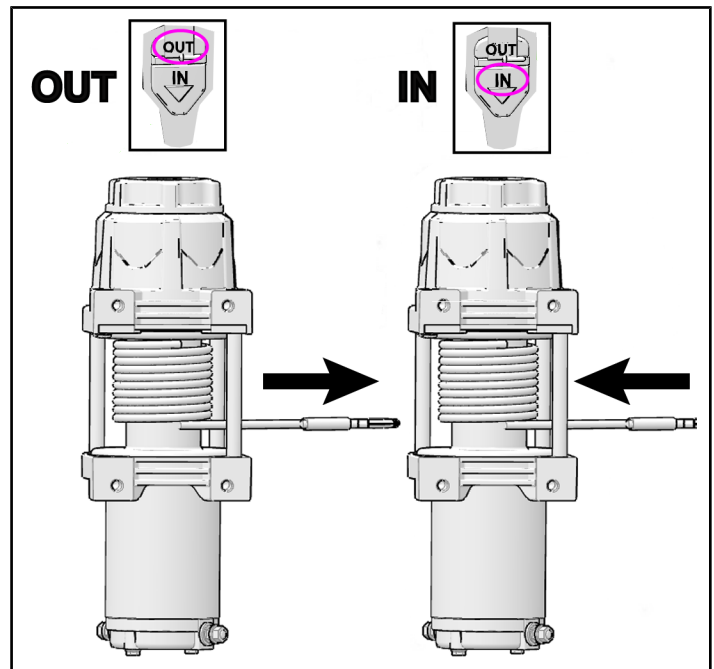

AUTOSTOP OPERATION

The Autostop system is meant to help prevent damage to the winch system from over-tightening of the rope, but is not meant to prevent all foreseeable winch damage. The winch system is very powerful and care should be exercised whenever it is in operation. The winch operator is always responsible for using the winch properly and the Autostop system should only be used as a secondary preventive measure to help prevent damage to the winch from over-tightening the rope.

The Autostop system works when the black rubber puck nears the aluminum fairlead. Stop magnets in the puck trigger sensors in the fairlead which prevent the winch from pulling in the rope any further.

During final inspection, confirm that the Autostop is functioning properly. See the troubleshooting section to help diagnose and correct any problems.

GEAR SELECTION

⚠ WARNING

Attempting to shift the winch while the rope is under tension is dangerous and can result in injuries or death. Make sure the winch rope is not in tension before shifting the winch between gears.

Your winch is equipped with three different gear settings. High, Neutral and Low. When in neutral the “N” marking will show thru the cutout window on the shift knob. See photo below.

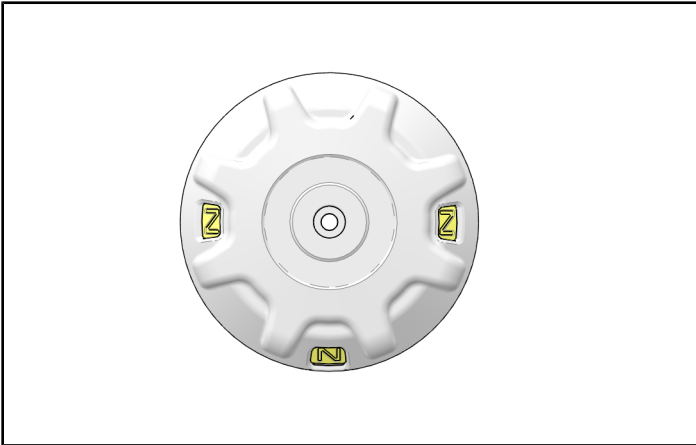

The high gear setting is meant for rapid recovery mode only and should not be used while the rope is under load. To shift into high gear, rotate the gear shifting knob clockwise until the “H” marking shows thru the cutout window on the shift knob. See photo below.

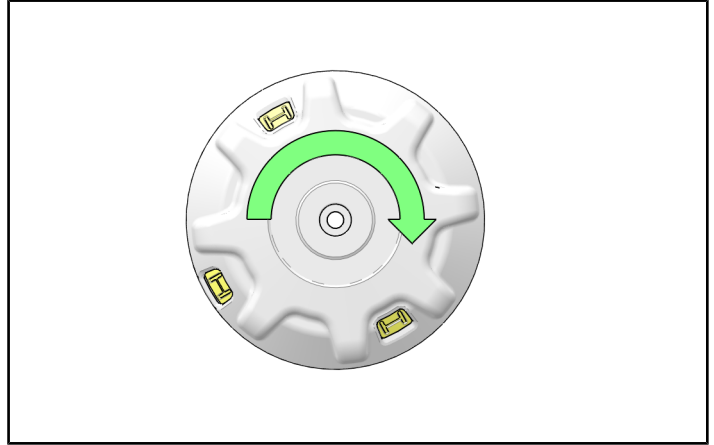

NOTE

High gear is for rapid recovery of the winch rope only. It is not intended for pulling and will reduce the life of the winch if used under load.

To shift into low, rotate the gear shifting knob counter-clockwise until the “L” marking shows thru the cutout window on the shift knob. See photo below.

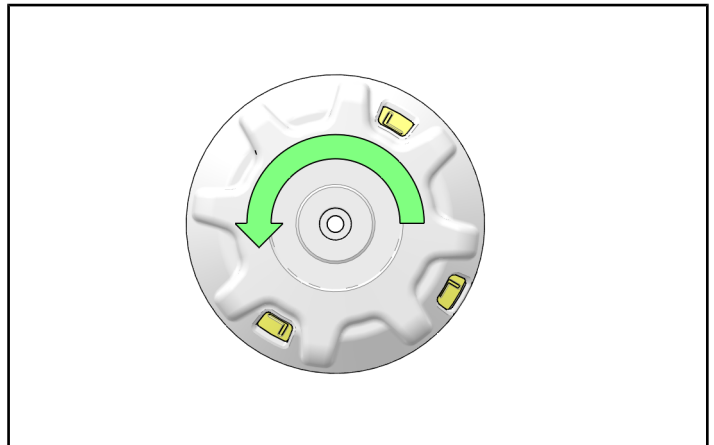

RAPID RECOVERY WINCH FUNCTION

NOTE

Rapid Recovery is for recovering the winch rope only. It is not intended for pulling and will reduce the life of the winch if used under load.

Your winch is equipped to quickly reel in the winch rope when being used under no-load conditions. Using this feature will significantly reduce the time it takes to rewind your rope after use.

When to use

Use Rapid Recovery to quickly reel the rope in or out to speed up the recovery process. The rope speed is approximately five times the speed of standard operation, so caution should be taken to always reset the winch to “Low” gear after using the Rapid Recovery so the speed of the winch will not take the operator by surprise. Do not pull loads while in Rapid Recovery gear.

How to shift

To operate the Rapid Recovery, make sure the winch is not in operation and the rope is not in tension. Rotate the shift knob fully clockwise to engage “High” gear (Rapid Recovery). Pulling slightly on the winch rope by hand will help the gears align and the shift to be completed. Use Rapid Recovery only to reel in the rope with “No Load”, then rotate the shift knob back to “Low” gear (standard operating mode) by rotating the knob back fully counter-clockwise.

WARNING

Attempting to shift the winch while the rope is under tension is dangerous and can result in injuries or death. Make sure the winch rope is not in tension before shifting the winch between gears.

TROUBLESHOOTING

If your winch/Autostop is not functioning properly, below is a short guide that can help you diagnose and correct the problem.

SYMPTOM	POSSIBLE CAUSES	RECOMMENDED SOLUTION
Dead Vehicle Battery	Check that all power wires are connected to the correct terminals per your instruction manual and not drawing any current while the vehicle sits for longer periods of time.	Rewire to ensure wiring is connected properly per instructions.
Winch will not operate	Contactors not receiving power	Turn vehicle key on.
	Wireless remote not powered on	Turn wireless remote on.
	Connections between components not in proper order	Check connections. Connect wired handlebar switch connection from vehicle main wire harness directly to contactor to make sure a direct connection will operate the winch. If connections are not in the order shown on the pictures in the last page, the whole system may not function or only certain parts of it will function.
Winch operates in one direction only	Keyed power circuit (orange wires) not properly powered	Check fusebox for 10A accessory circuit. Check voltage in certain places, especially orange wires coming out of the main harness by the steering post.
	Autostop fairlead not connected properly	Check connections. If winch operates only outward, check that the black rubber puck is not touching the aluminum fairlead. If winch operates inward even when puck is touching fairlead, check connections of the Autostop control box. If winch operates inward but not outward when rubber puck is touching fairlead, check color of wires at connectors to make sure they match on both sides of the connection (in case two wires have been switched in the connector).
Winch makes noise but rope does not move	Contactors powered, but not winch	If you can hear a clicking sound when you press the winch control but the winch does not make any sounds, check the connections between the winch and the contactor. If the winch makes noise but does not move, check that the winch is in gear. If the winch is in gear and the winch does not move, have a dealer inspect the winch.

SYMPTOM	POSSIBLE CAUSES	RECOMMENDED SOLUTION
Winch makes noise but rope does not move	Winch not in proper gear	Rotate gear knob fully into L or H, then recheck.
Winch operates too slowly	Winch in wrong gear	Rotate gear knob into proper gear, then recheck.
	Winch improperly loaded	The winch, by design, operates slowly in Low gear. In High (Rapid Recovery), the winch operates quickly but can be slowed if there is a load on the rope or if the rope is bound up inside the spool area. Check that the winch is clear and the rope is not bound up and that there is no load pulling on the rope.
Winch will not change gears	Rope is still under load	The gears are purposely hard to shift when a load is on the rope to prevent accidental operation, which could lead to winch failure or personal injury. Make sure the rope has no load in tension, then check that the rope is not bunched up and bound inside the spool area. Operate the winch for a short period, then attempt to shift again.

ELECTRICAL CONNECTION REFERENCE GUIDE

Winch with auto fairlead and wireless remote

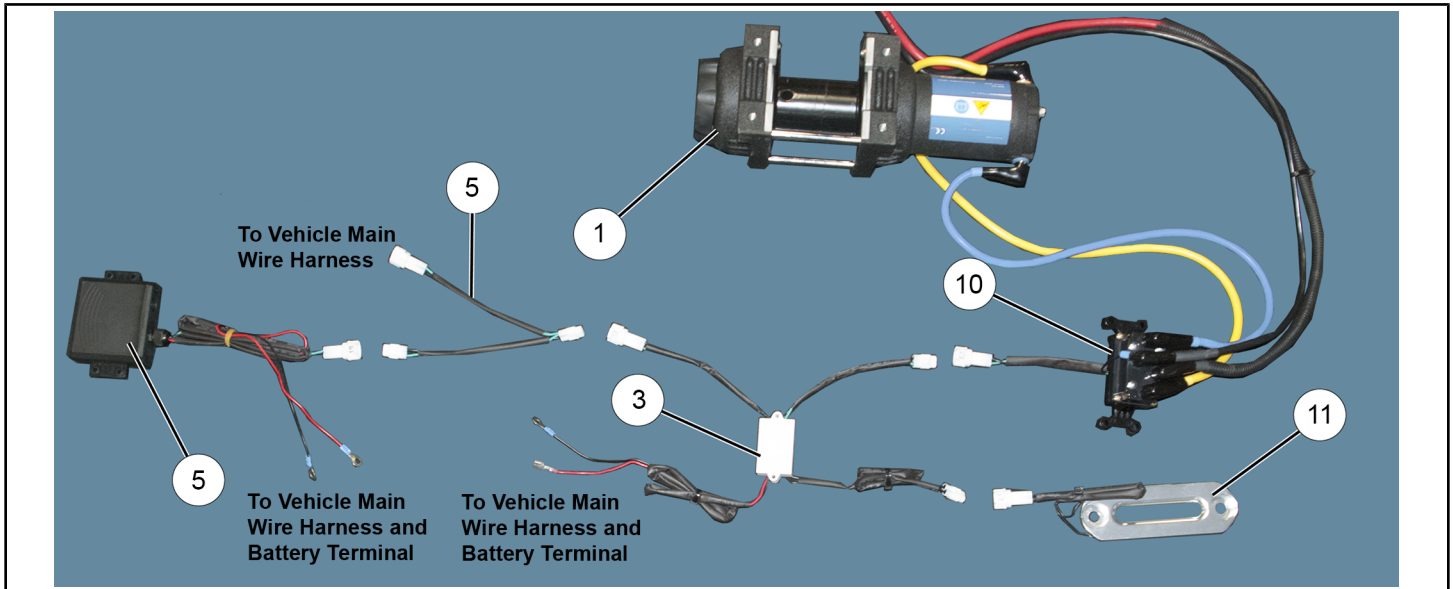

FEEDBACK FORM

A feedback form has been created for the installer to provide any comments, questions or concerns about the installation instructions. The form is viewable on mobile devices by scanning the QR code or by clicking [HERE](#) if viewing on a PC.

