

BUS BAR POWER WIRING KIT

P/N 2879990



POLARIS®

Application

2014 RANGER 570

Before you begin, read these instructions twice and check to be sure all parts and tools are accounted for. Please retain these installation instructions for future reference and parts ordering information.

Kit Contents:

<u>Qty</u>	<u>Part Description</u>	<u>Part Number</u>
1	Cable-Power, Winch, Black 6 GA	4013470-2135
1	Cable-Power, Winch, Red 6 GA	4013471-2135
8	Panduit Strap, 160X3.2	7080492
1	Instructions	9925142

Tools Required:

Safety Goggles

Torx Set

Ratchet and Metric Sockets

APPROXIMATE ASSEMBLY TIME: 30 minutes

IMPORTANT: Your Polaris BUS BAR POWER WIRING KIT is exclusively designed for your vehicle. Please read the installation instructions thoroughly before beginning. Installation is easier if the vehicle is clean and free of debris. For your safety and to ensure a satisfactory installation, perform all installation steps correctly and in the sequence shown. Before you begin, make sure to thoroughly review the instructions.

HARNESS ROUTING:

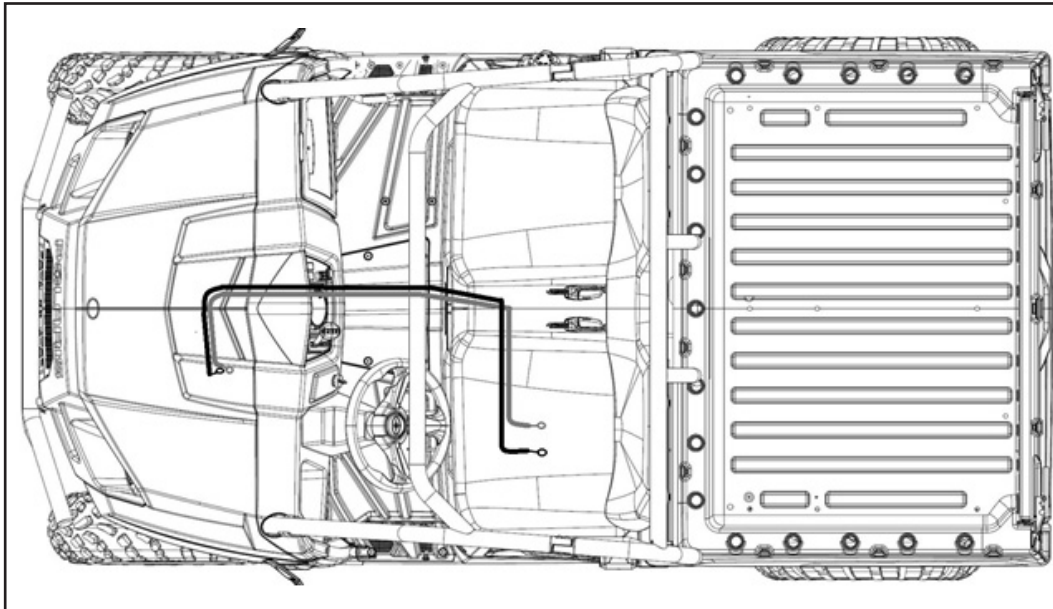

INSTALLATION INSTRUCTIONS:

1. Place the vehicle in "PARK" and turn the key to "OFF" position. Remove the key from vehicle.
2. Pivot the hood forward and remove the seat base.
3. Remove the center drive shaft cover by removing eight screws. Figure 1.

NOTE: Retain the fasteners for later use.

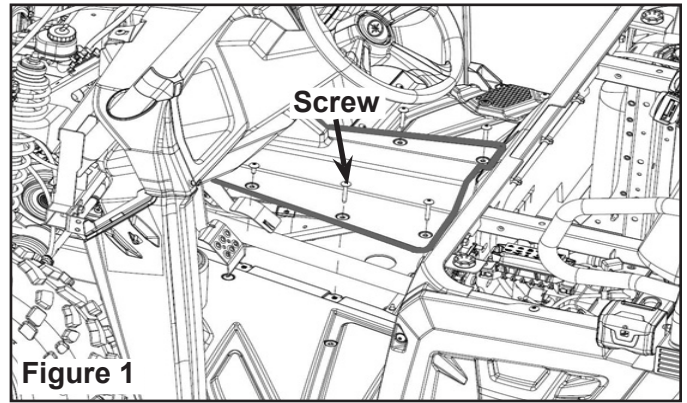

4. Route the red wire (PN 4013471-2135) along the main wire harness and connect one end of the wire harness to top post (positive) of the three post block terminal and other end to the battery positive.
5. Follow the same routing as Step 4, route the black wire (PN 4013470-2135) and connect one end of the wire harness to the center post (ground) of the three post block terminal and other end to the battery ground as shown. Figure 2.
6. Reinstall the seat base, center drive shaft cover and pivot the hood back to its original position.

