

# BOX LIFT INSTALLATION KIT P/N 2879733



Application  
BRUTUS

Before you begin, read these instructions twice and check to be sure all parts and tools are accounted for. Please retain these installation instructions for future reference and parts ordering information.

## This Kit Includes:

Qty	Part Description	Part Number
1	Wire Harness	2412229
1	Lift Switch	4010634
1	Box Lift	4013620
6	Panduit Straps	7080138
1	Instructions	9924519

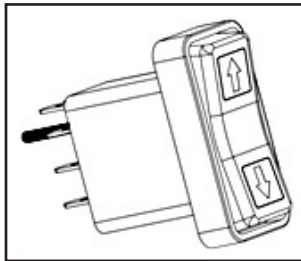

Lift switch

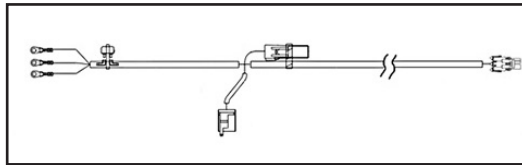

Wire Harness

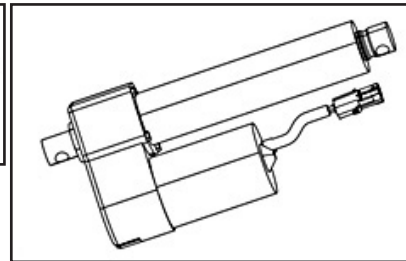

Box lift

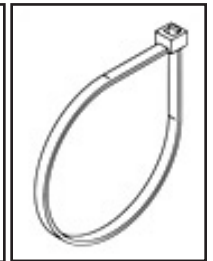

Panduit Straps

## Tools Required:

Safety Glasses  
1/4" Ratchet with 8 mm Deep Well Socket

Pliers from the vehicle tool kit  
Utility Knife (Optional)

Wire Side Cutters  
Utility Knife (Optional)

APPROXIMATE INSTALLATION TIME: 30 minutes

## Connection Diagram

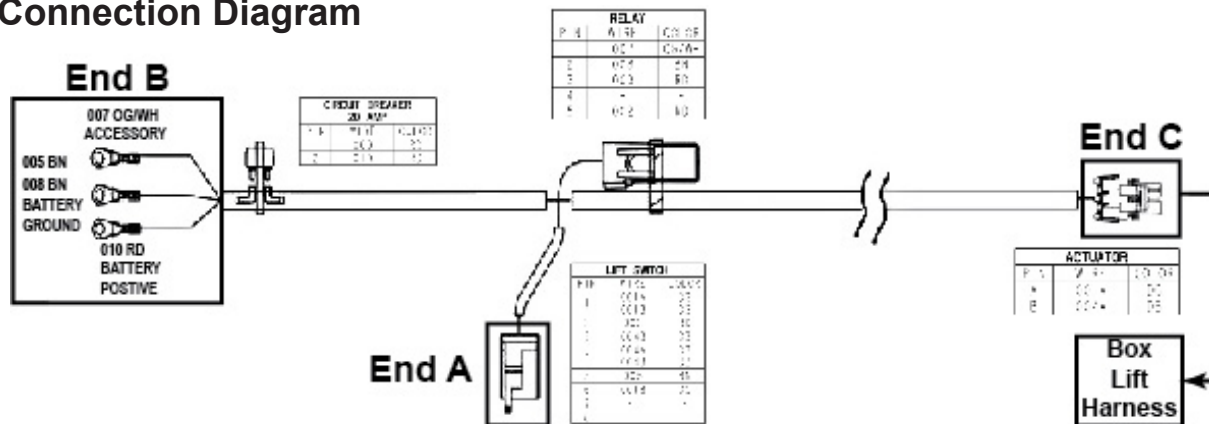

WIRE TERMINATION TABLE							
CCT #	TYPE	COLOR	GAUGE	FROM CONNECTOR	CAVITY	TO CONNECTOR	CAVITY
001A	TXL	DK GREEN	2.0	LIFT SWITCH	1	ACTUATOR	A
001B	TXL	DK GREEN	2.0	LIFT SWITCH	1	LIFT SWITCH	6
002	TXL	RED	2.0	LIFT SWITCH	2	RELAY	5
004A	TXL	DK BLUE	2.0	LIFT SWITCH	4	ACTUATOR	B
004B	TXL	DK BLUE	2.0	LIFT SWITCH	4	LIFT SWITCH	3
005	TXL	BROWN	2.0	LIFT SWITCH	5	BATTERY GROUND	6MM RNG
007	TXL	ORANGE/WHITE	0.8	RELAY	1	ACCESSORY	6MM RNG
008	TXL	BROWN	0.8	RELAY	2	BATTERY GROUND	6MM RNG
009	TXL	RED	2.0	RELAY	3	CIRCUIT BREAKER	1
010	TXL	RED	2.0	CIRCUIT BREAKER	2	BATTERY POSITIVE	6MM RNG

## Installation and Wiring Diagram

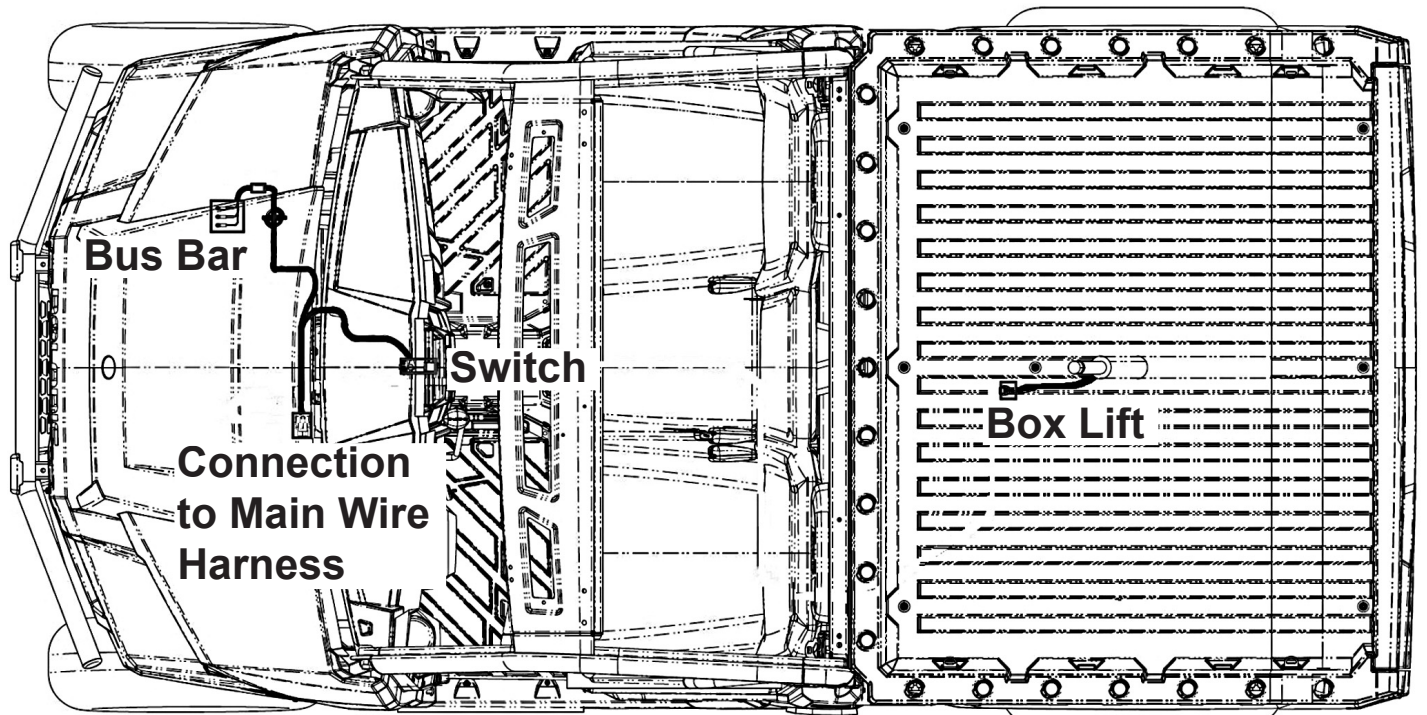

### INSTALLATION INSTRUCTIONS:

1. Put vehicle in park. Turn key to "OFF" position and remove key from vehicle.
2. Remove passenger seat and storage tray. Disconnect black negative battery cable from battery. Disconnect red positive cable from battery.
3. Remove the four plastic rivets from the upper dash panel with the pliers. Figure 1.
4. Remove the upper dash panel by pulling up.
5. Twist the two hood knobs in the direction shown in Figure 2.
6. Remove the center hood by pulling forward. Figure 2.

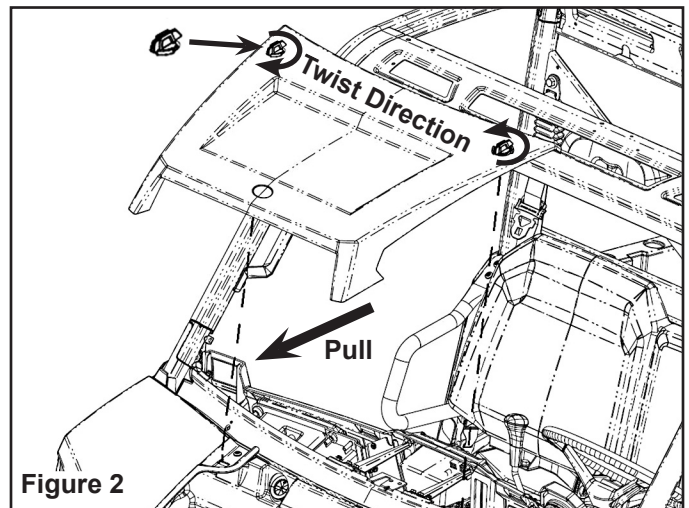
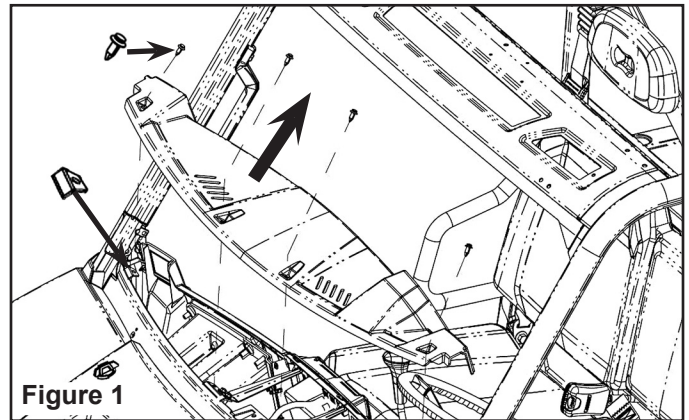

7. Unlatch and raise the box to the highest angle as shown in Figure 3.
8. Remove the box latch by removing the two M8 bolts.
9. Remove shock by removing the spring pin and clevis pin from both ends of the shock.

**NOTE:** Retain spring pin and clevis pin for reinstallation.

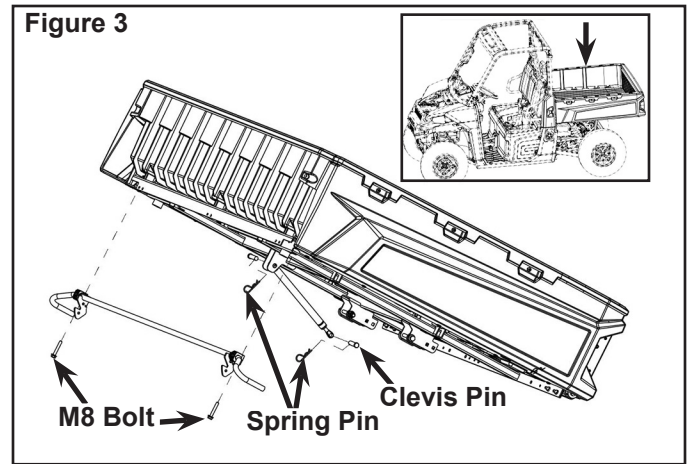

10. Route End A with connector (see Connection Diagram) of the wire harness from top of the dash. Insert the connector into the slot in dash control panel. Figure 4.

**IMPORTANT:** Keep the flange of the connector on top while inserting.

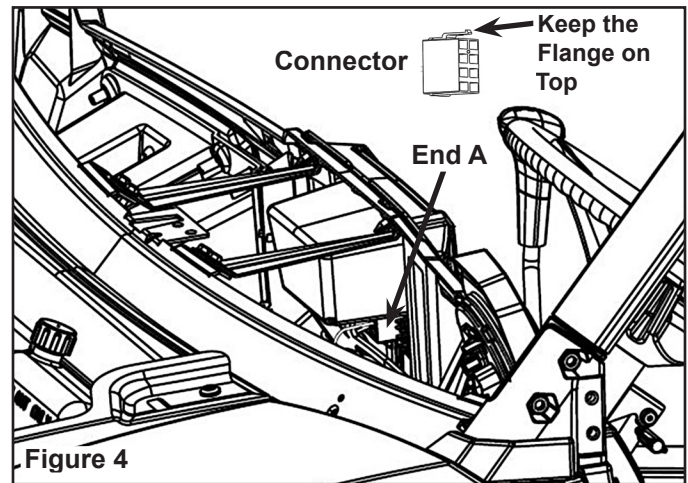

**NOTE:** If the factory cut slot is used for a different accessory, you will need to cut a new slot. You can cut a slot with the center control panel left installed to the vehicle using a utility knife. Follow the scribe line in the slot area of plastic panel. Figure 5.

**IMPORTANT:** Make sure you do not cut any wires behind the center control panel.

Or you can remove the center control panel by removing the two lower screws. Pull off center control panel. Disconnect wire harnesses from the back of the control panel. It is helpful during reassembly if you mark your where your wires go as you unplug them. Using a utility knife, follow the scribe line in the back of the plastic panel. Reconnect the wire harness and reinstall the center control panel using the two screws removed earlier.

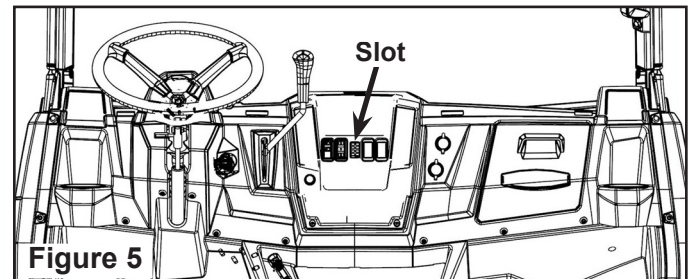



11. Insert the lift switch into the connector in the dash control panel.

**IMPORTANT:** Keep the protruded pin on top when inserting.

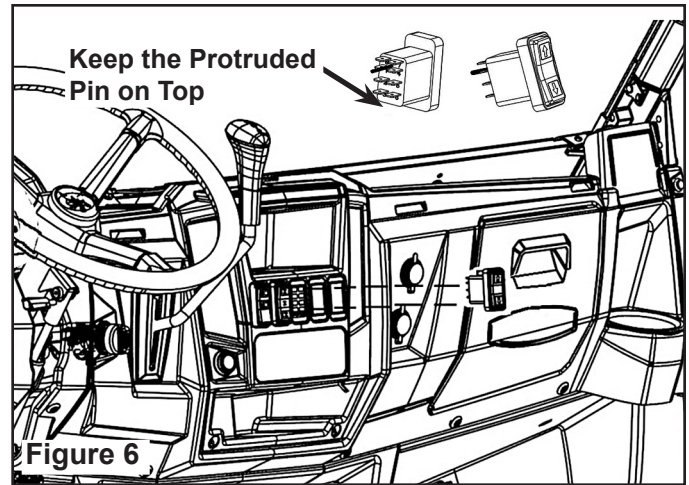

12. Route End B (see Connection Diagram) to the through the grommet in the windshield plate to the 3-post block terminal. Figure 7.

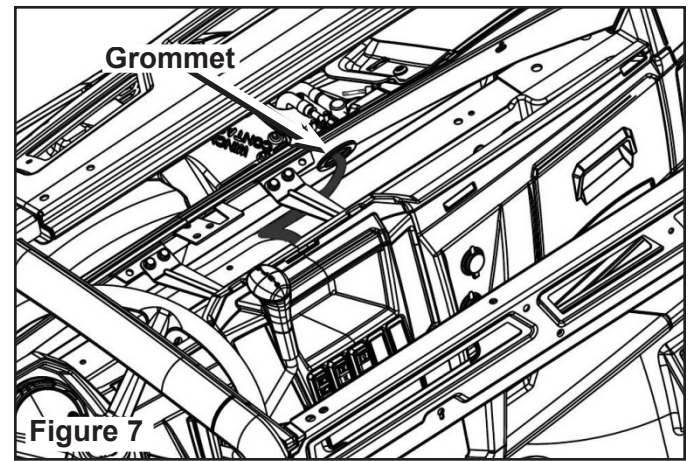

13. Connect End B of the wire harness to the 3 post block terminal. Figure 8

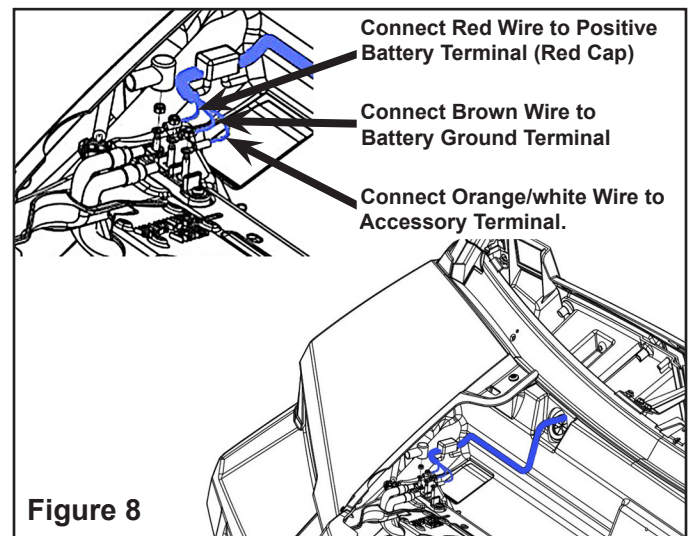

14. Insert End C of the wire harness to the connector on the main wire harness. Figure 8

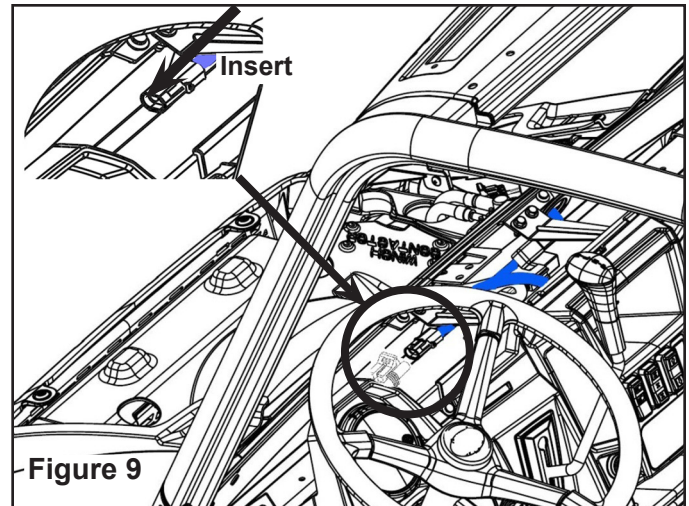

15. Put the box lift onto the vehicle using the clevis pin and spring pin. One end should be attached to the chassis and other end to the box. Figure 10.

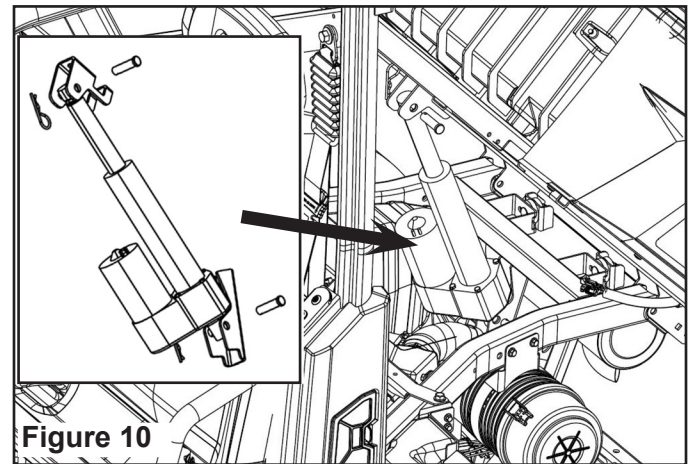

16. Uncap the harness connector.  
17. Connect the box lift connector to the harness connector. Figure 11.  
18. Reconnect battery positive cable (red) and the negative cable (black) that were removed in Step 2.  
19. Confirm the function of the lift by turning on the vehicle (you may be required to start the vehicle) and operating the box lift up and down.

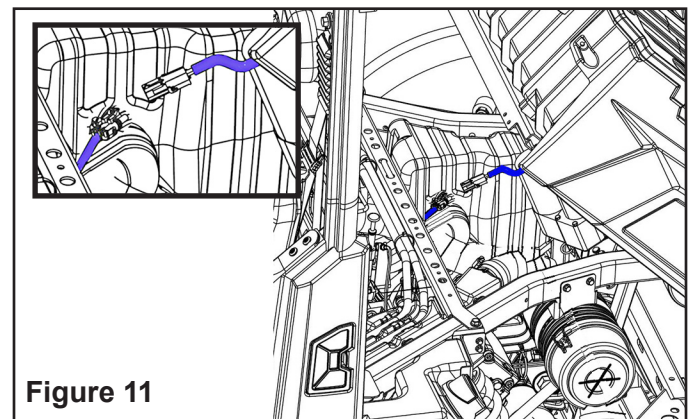

- NOTE:** Make sure wire harness is secure to prevent unwanted movement, especially in locations with rotating parts or hot parts. Check that the harness does not interfere with movement of the box as it travels up and down and make sure the harness is not pinched by the box when it is closed.
20. Reinstall dash cap, center hood, passenger seat and storage tray.