

# CREW HALF DOOR KIT



P/N 2883438

## APPLICATION

Verify accessory fitment at [Polaris.com](http://Polaris.com).

## BEFORE YOU BEGIN

Read these instructions and check to be sure all parts and tools are accounted for. Please retain these installation instructions for future reference and parts ordering information.

## KIT CONTENTS

### NOTE

The lower DOOR-SIDE hinges required to install these rear doors are not included in this kit. They are included in Front Half Door Kit 2882559 and in service kit 2207760.

Similarly, the CHASSIS-SIDE hinges required to install these rear doors are not included in this kit. They are included in Front Half Door Kit 2882559 and in service kit 2207759.

See section **INSTALLATION INSTRUCTIONS**, Steps 3–4, for detail.

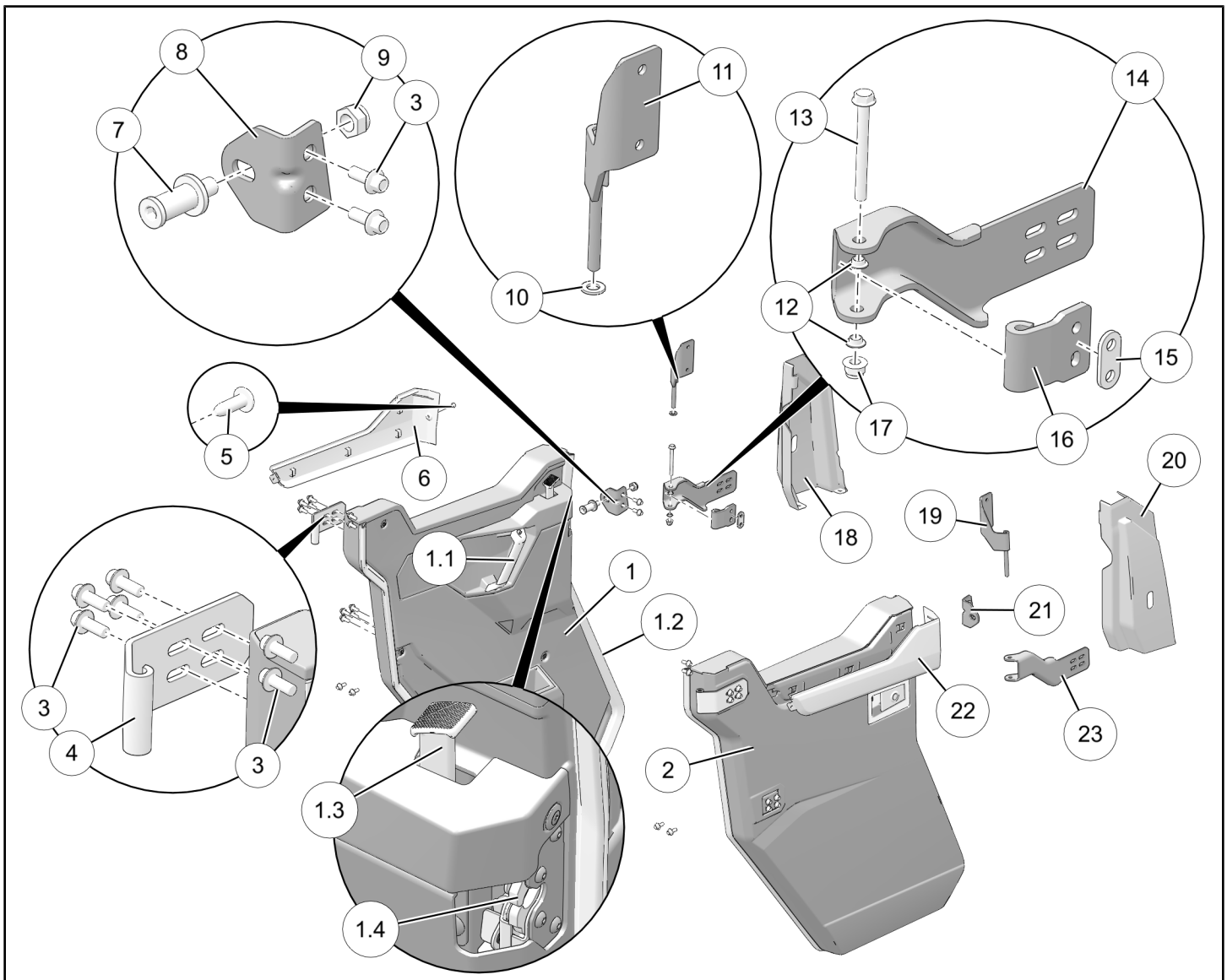

REF	QTY	PART DESCRIPTION	PART NUMBER	INCLUDED IN SERVICE KIT
1	1	Door Assembly, LH (includes items 1.1–1.5)	2637350	-
1.1	1	- Handle, Grab, LH	-	2207851
1.2	1	- Seal, Door, Perimeter	-	2207924*
1.3	1	- Handle, Interior Latch	-	2207922
1.4	1	- Latch Assembly, Interior, LH	-	2207923
1.5	1	- Latch Assembly, Exterior (not shown)	-	2207716
2	1	Door Assembly, RH (includes items 2.1, 2.4; all <b>other</b> parts same as those identified in 1.x above)	2637351	-
2.1	1	- Handle, Grab, RH	-	2207851
2.4	1	- Latch Assembly, Interior, RH	-	2207923
3	28	Screw, Hex Flange - M8 X 1.25 X 20	7519936	2207920 (qty: 16)
4	2	Hinge, Door-Side, Upper	-	2207920
5	2	Screw, Torx® Truss Head, High/Low - #14 X 3/4	7519045	-
6	1	Panel, Accent, LH	5454768-070	-
7	2	Pin, Striker	-	2207921
8	1	Bracket, Striker, LH	-	2207921
9	2	Nut, Hex - M12 X 1.75	7540000	2207921
10	2	Washer, Nylon - 10.25 X 19.0 X 2.0	5439712	2207920
11	1	Hinge, Chassis-Side, Upper LH (front door)	-	2207920
12	4	Bushing, Lower Door-Side Hinge (front door)	-	2207920
13	2	Screw, Hex Flange - M8 X 1.25 X 80	7521048	2207920
14	1	Hinge, Door-Side, Lower LH (front door)	-	2207920
15	2	Spacer	5265312	2207920
16	2	Hinge, Chassis-Side, Lower (front door)	-	2207920
17	2	Nut, Hex Flange, Locking - M8 X 1.25	7547661	2207920
18	1	Cover, B-Pillar, LH	5454372-070	-
19	1	Hinge, Chassis-Side, Upper RH (front door)	-	2207920
20	1	Cover, B-Pillar, RH	5454373-070	-
21	1	Bracket, Striker, RH	-	2207921
22	1	Panel, Accent, RH	5454769-070	-
23	1	Hinge, Door-Side, Lower RH (front door)	-	2207920
	1	Instructions	9928646	-

\* Service kit contains parts and hardware required for ONE side of vehicle.

## TOOLS REQUIRED

- Safety Glasses
- Pliers, Push Pin Rivet
- Screwdriver Set, Torx®
- Socket Set, Hex Bit, Metric
- Socket Set, Metric
- Socket Set, Torx® Bit
- Torque Wrench
- Wrench Set, Metric

## CONSUMABLES REQUIRED

- Gloves, Chemical Resistant
- Grease, Polaris All Season (or equivalent)

## IMPORTANT

Your Crew Half Door Kit is exclusively designed for your vehicle. Please read the installation instructions thoroughly before beginning. Installation is easier if the vehicle is clean and free of debris. For your safety, and to ensure a satisfactory installation, perform all installation steps correctly in the sequence shown.

## ASSEMBLY TIME

Approximately 75–90 minutes

## INSTALLATION INSTRUCTIONS

### IMPORTANT

Polaris recommends completing installation Steps 1–4 of this Crew Half Door Kit **PRIOR TO** installing Front Half Door Kit 2882559.

Installation of FRONT door hinges on **crew** vehicles is different from installation on **non-crew** vehicles. See Steps 3–4 for detail.

### NOTE

Polaris recommends two people install this kit.

1. Shift vehicle transmission into “PARK”. Turn ignition switch to “OFF” position and remove key.
2. Raise vehicle bed.
3. Remove and replace lower door-side hinge on **FRONT** door.

### IMPORTANT

The lower door-side hinges included in this Crew REAR Door Kit will be used on the FRONT doors. Conversely, the lower door-side hinges installed on the FRONT doors (sold separately) will be used on the Crew REAR doors.

Swapping hinges is required to accommodate different hinge mounting structure between crew and non-crew vehicles.

As a result, do NOT follow front door hinge installation instructions included in the Front Door Kit. Follow these instructions instead.

- a. Remove LH lower door-side hinge ① from FRONT door (sold separately) by removing four screws ②. Retain hinge and screws.

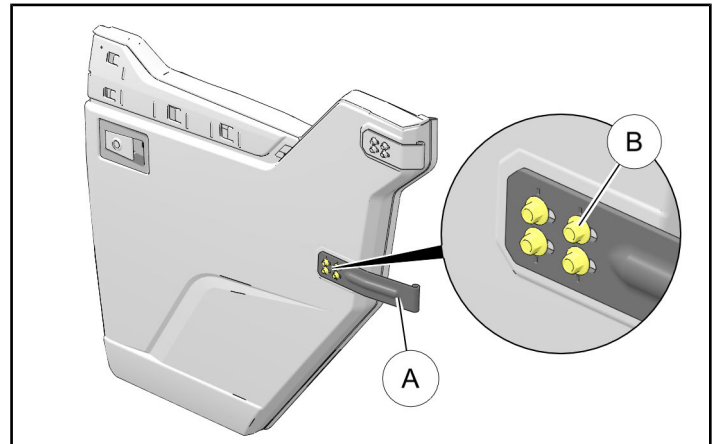

- b. Identify new LH lower door-side hinge ⑭. Notice differences from RH lower door-side hinge ⑮.

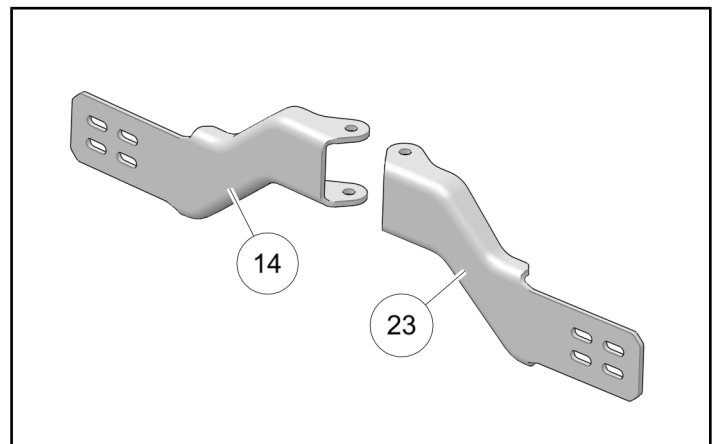

- c. Loosely install LH lower door-side hinge ⑭ using four retained screws ②.

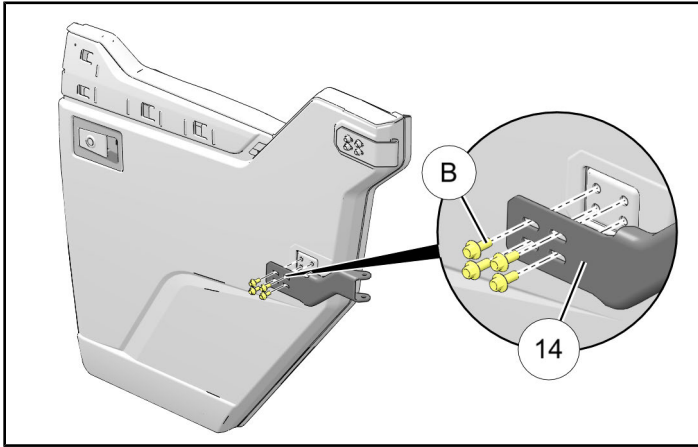

- c. Install new LH B-pillar cover ⑱ using retained screws ③ and push-pin rivets ④ and ⑤.

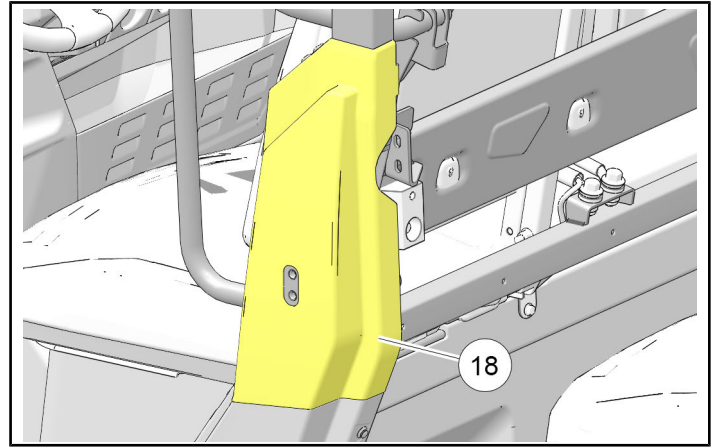

4. Install chassis-side hinges for **FRONT** door.

### IMPORTANT

The chassis-side hinges included in this Crew REAR Door Kit will be used on the FRONT doors. Conversely, the chassis-side hinges included in the FRONT Door Kit (sold separately) will be used on the Crew REAR doors.

Swapping hinges is required to accommodate different hinge mounting structure between crew and non-crew vehicles.

As a result, do NOT follow front door hinge installation instructions included in the Front Door Kit. Follow these instructions instead.

- a. Remove two screws ③ from top of existing B-pillar cover. Retain screws.

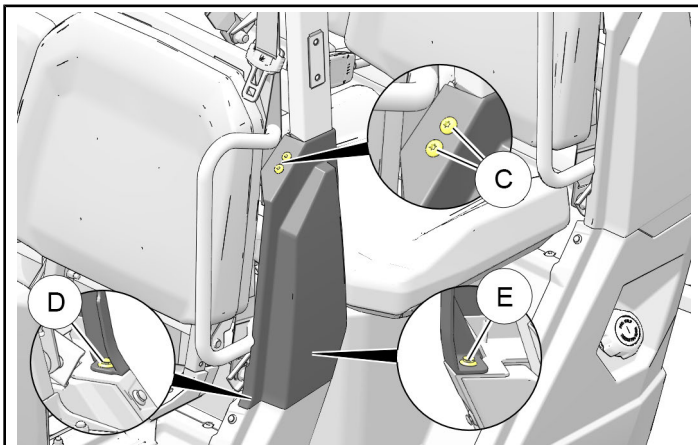

- b. Remove two push pin rivets from bottom interior of B-pillar cover (front rivet ④ and rear rivet ⑤), then remove cover. Retain rivets. Cover will not be reused.

- d. Loosely install spacer ⑮ and lower chassis-side hinge ⑯ to B-pillar fitting using two screws ⑥.

### NOTE

Screws ⑥ (M8 X 1.25 X 20 hex flange) are included in FRONT door kit.  
Lower chassis-side hinge ⑯ is identical for LH and RH sides.

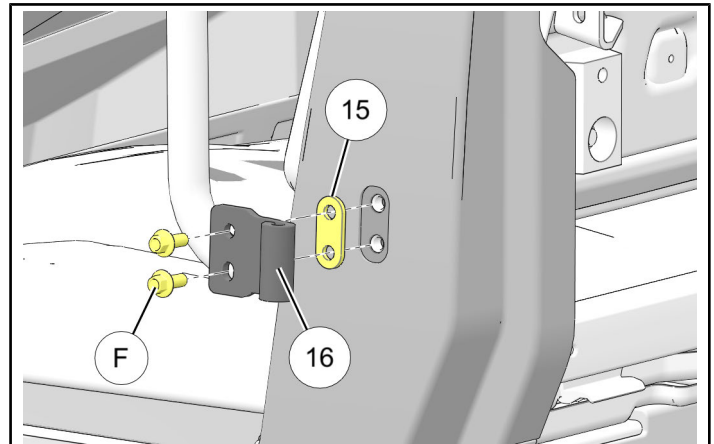

- e. Identify LH upper chassis-side hinge ⑪. Notice differences from RH upper chassis-side hinge ⑲.

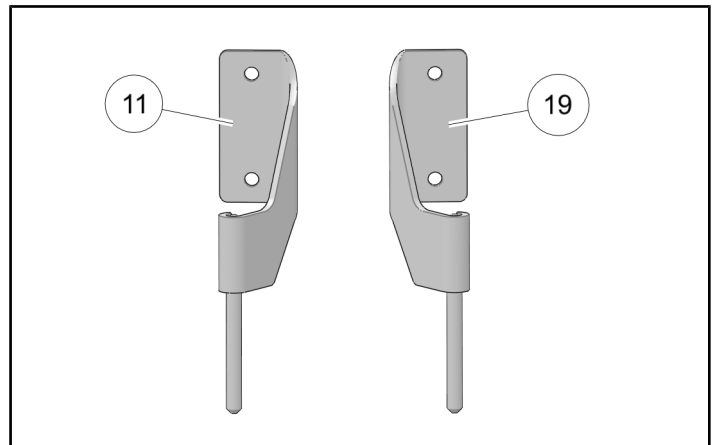

- f. Loosely install upper LH chassis-side hinge ⑪ to B-pillar fitting using two screws ⑤.

**NOTE**

Screws ⑤ (M8 X 1.25 X 20 hex flange) are included in FRONT door kit.

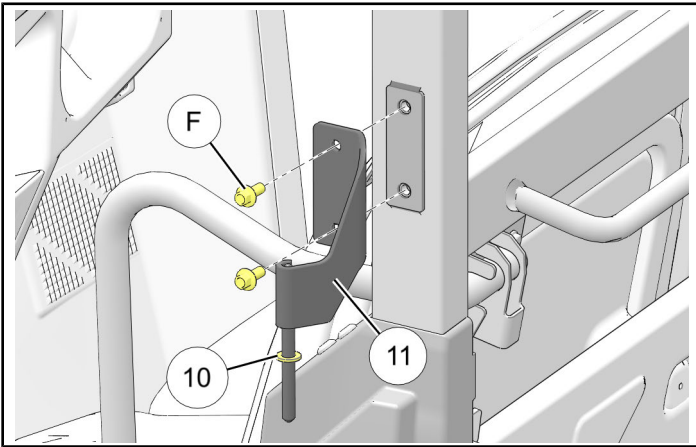

- g. Install nylon washer ⑩ to hinge pin.

**NOTE**

Washer acts as bearing surface to assist in smooth door operation.

**⚠ WARNING**

Follow all chemical manufacturer instructions and safety precautions. Failure to follow all manufacturer instructions and precautions may result in severe injury or death.

- h. Grease pin on upper chassis-side hinge ⑪ and screw ⑬ with Polaris All Season Grease (or equivalent).
- i. Insert first bushing ⑫ UPWARDS into LH lower door-side hinge ⑭ as shown.

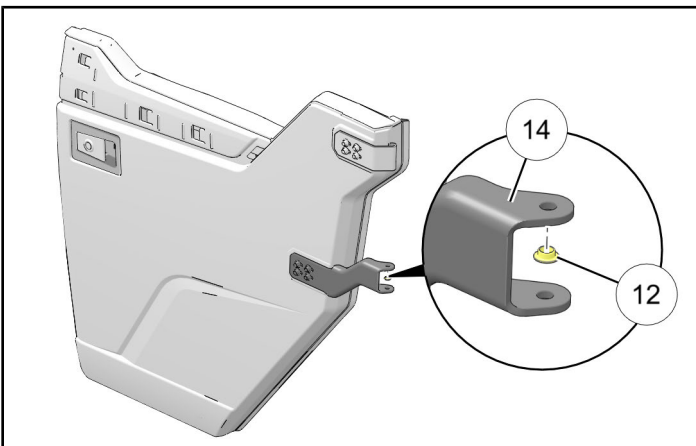

- j. Install front door assembly on upper chassis-side hinge ⑪. Align door with lower chassis-side hinge ⑮, then install screw ⑬. Ensure nylon washer ⑩ and first bushing ⑫ remain in place.

Install second bushing ⑫ UPWARDS into lower hinge, then secure with nut ⑰. Torque to specification.

**TORQUE**

5 ft. lbs. (7 Nm) ± 10%

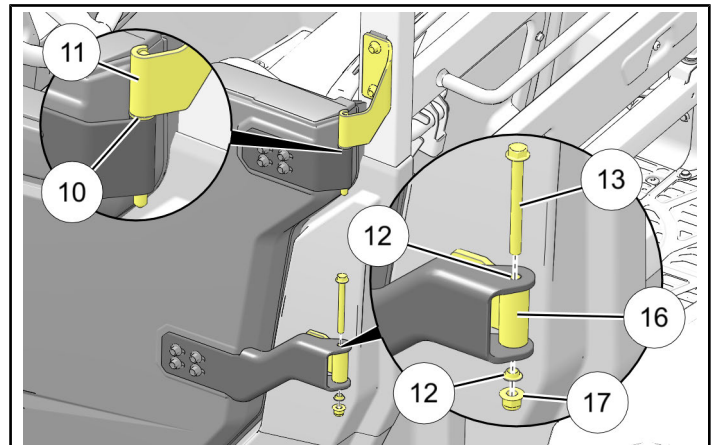

- k. Continue with front door installation per instructions provided with Front Door Kit.

When door adjustment is complete, ensure four chassis-side hinge screws ⑤ and four door-side hinge screws ⑧ are torqued to specification.

**TORQUE**

17 ft. lbs. (23 Nm) ± 10%

5. Install door-side hinges for **REAR** door.
  - a. Loosely install upper door-side hinge ④ to LH rear door ① using four screws ③.

**NOTE**

Upper door-side hinge ④ is identical for LH and RH sides; hinge may be pre-installed from factory.

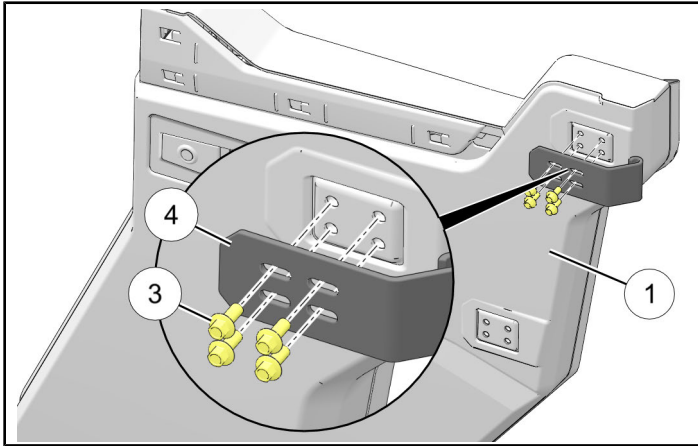

- b. Loosely install LH lower door-side hinge ① (removed from front door in Step 3) to LH rear door ① using four screws ③.

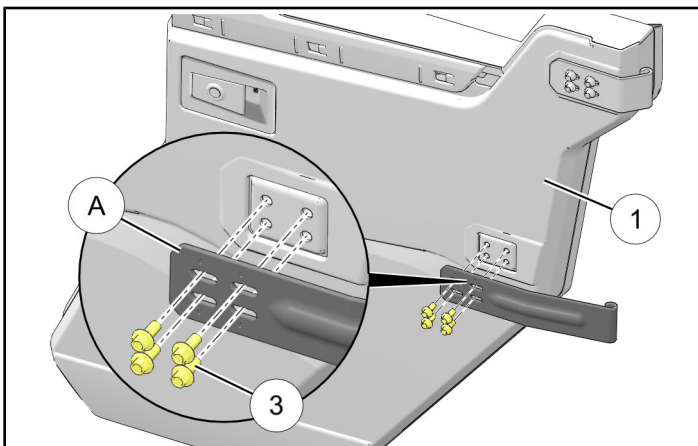

6. Install chassis-side hinges for **REAR** door.
  - a. Locate the following loose parts included in the **FRONT DOOR KIT**:

- Lower LH chassis-side hinge ⑥
- Lower RH chassis-side hinge ⑧

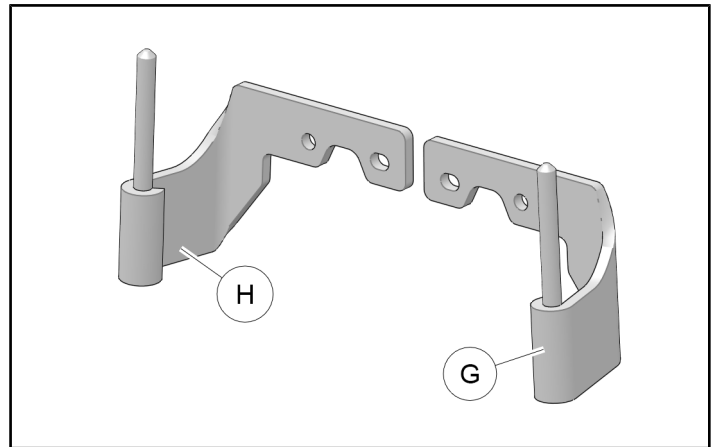

- Upper LH chassis-side hinge ⑩
- Upper RH chassis-side hinge ⑫

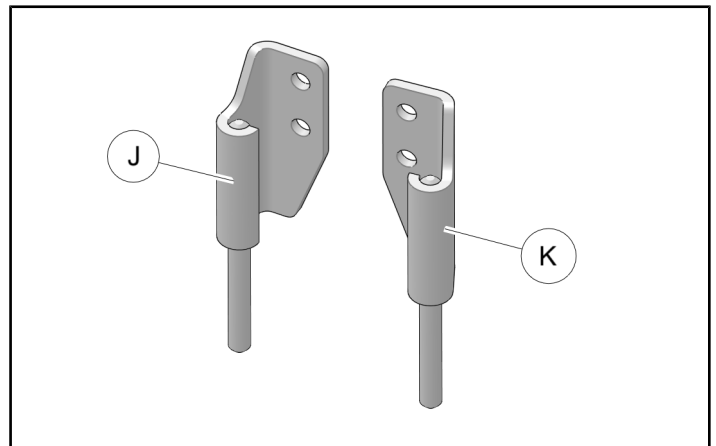

- Nut plate ⑬ (quantity 2)
- Nylon washer ⑭ (quantity 4)

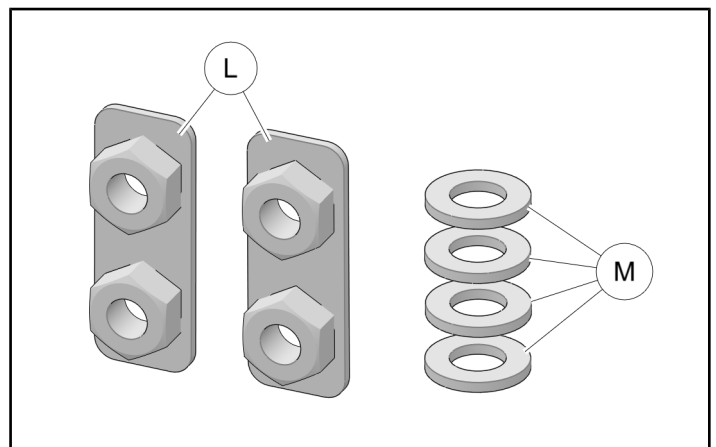

- b. Install lower LH chassis-side hinge ⑥ to chassis fitting using two screws ③. Tighten screws.

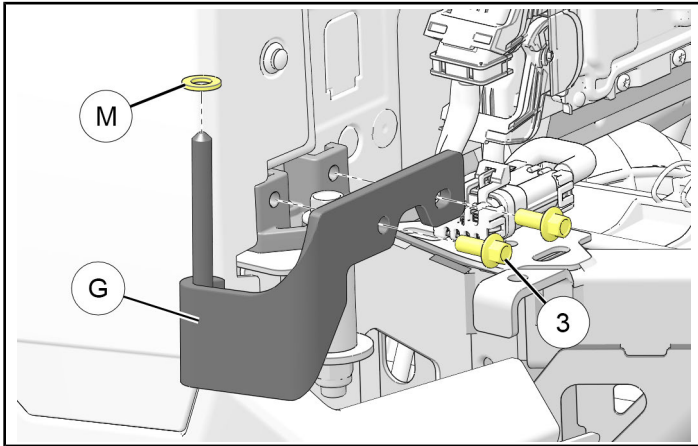

7. Install LH door assembly on lower chassis-side hinge ⑥, then loosely install upper chassis-side hinge ① to C-pillar mounting bracket using two screws ③ and nut plate ①. Tighten screws.

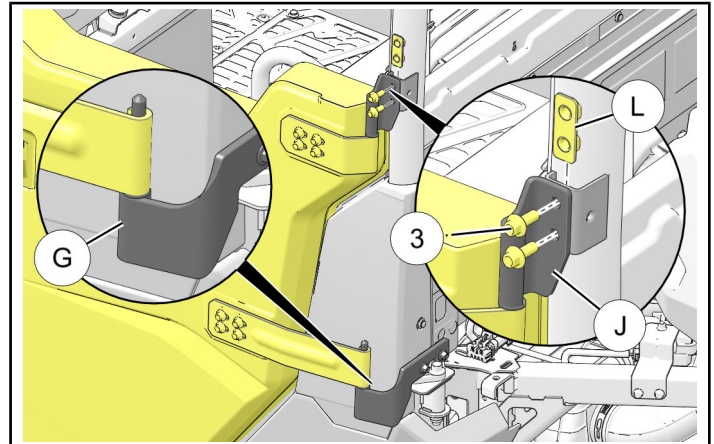

**WARNING**  
Follow all chemical manufacturer instructions and safety precautions. Failure to follow all manufacturer instructions and precautions may result in severe injury or death.

- c. Install nylon washer ① to hinge pins on lower LH chassis-side hinge ⑥ and upper LH chassis-side hinge ①.  
Grease pins with Polaris All Season Grease (or equivalent).  
d. Insert upper LH chassis-side hinge ① into upper door-side hinge ④.

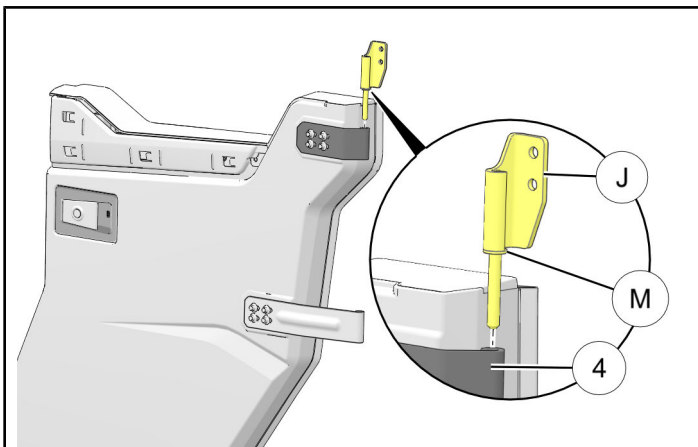

8. Ensure eight upper and lower DOOR-SIDE hinge screws ③ are slightly loose (see Step 5), then close door. Push door inwards while centering door in ROPS/chassis opening, then tighten screws.

If door cannot be centered, loosen upper and/or lower CHASSIS-SIDE screws ③, center door, then retighten all screws. If necessary, upper and/or lower nylon washers ① may also be removed.

**TIP**  
Have one person push and center the door, and a second person tighten the screws.

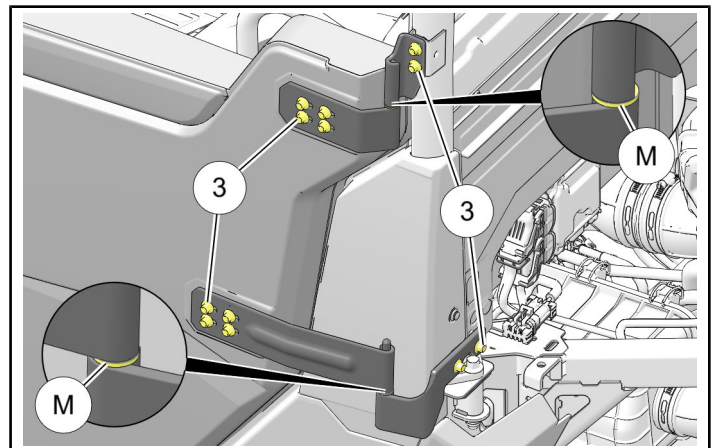

9. Torque all four chassis-side hinge screws ③ and all eight door-side hinge screws ③ to specification.

**TORQUE**  
17 ft. lbs. (23 Nm) ± 10%

10. Assemble and install striker.

- a. Identify **LH** striker bracket ⑧. Notice differences from **RH** striker bracket ⑳.

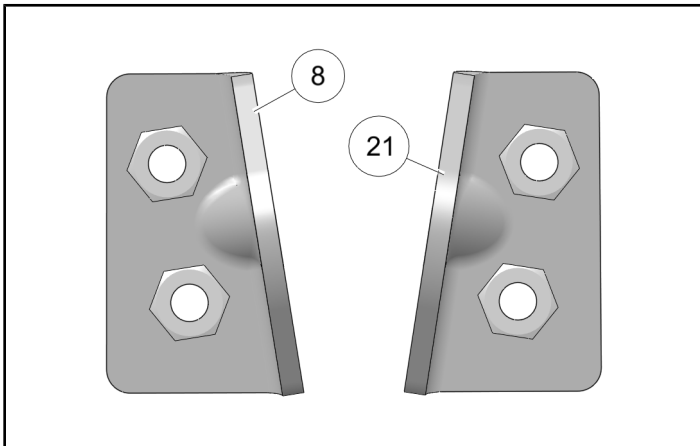

- b. Install striker pin ⑦ to LH striker bracket ⑧ using nut ⑨. Center pin in slot, then tighten nut.

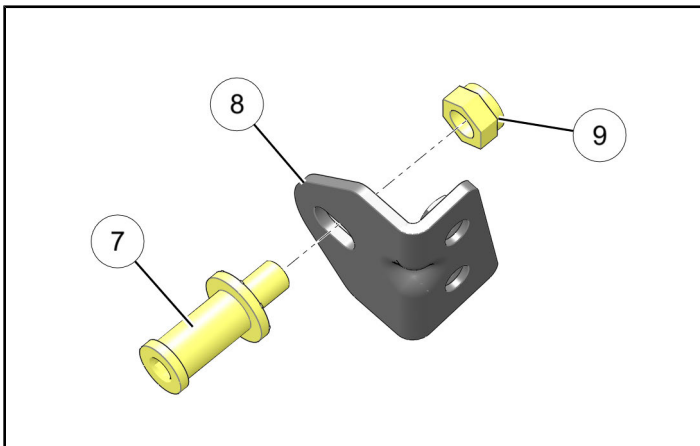

- c. Install LH striker bracket ⑧ assembly to chassis using two screws ③. Center bracket in slots, then tighten screws.

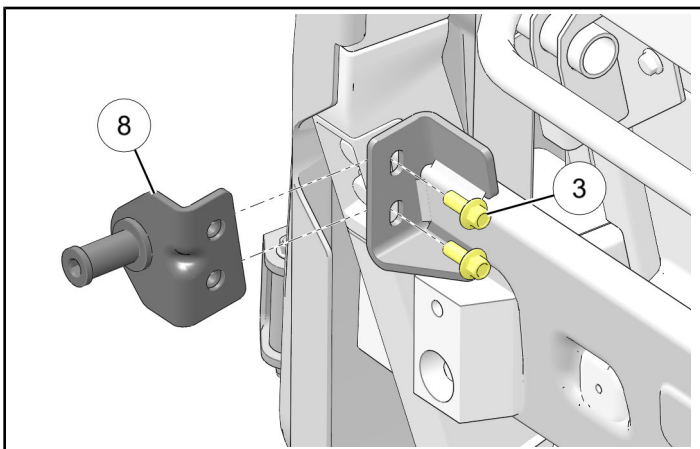

11. Open door latch (to properly position pawls), then slowly close door and observe engagement of striker pin ⑦ into door latch.

Adjust striker pin and/or LH striker bracket ⑧ to achieve the following:

- a. **HEIGHT** ①: Pin ⑦ should be centered vertically between upper and lower latch pawls ②. To adjust, loosen two screws ③, slide LH striker bracket ⑧ up or down as required, then retighten screws.

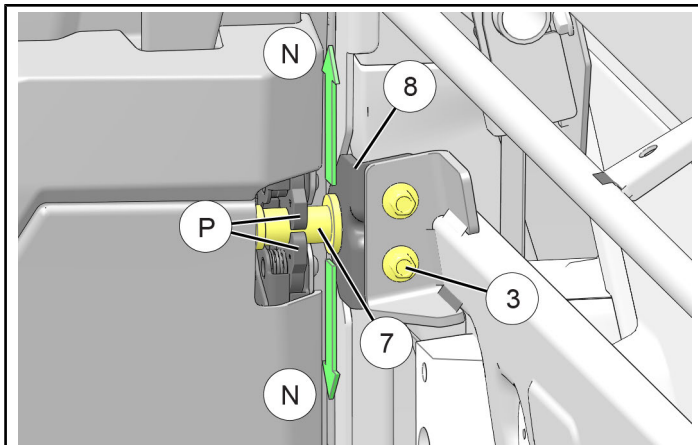

- b. **DEPTH** ④: As required to achieve desired seal compression and door fairing. To adjust, loosen nut ⑨, slide striker pin ⑦ inboard or outboard as required, then retighten nut.

Ensure depth adjustment is made with latch pawls ② at FULL closure as shown below (second "click"), not at partial closure (first "click").

**NOTE**

Nut can be accessed by reaching up from below striker bracket.  
LH striker bracket ⑧ shown partially transparent for clarity.

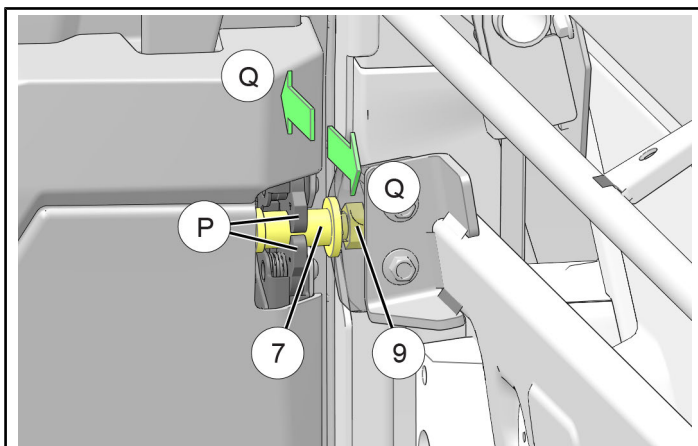



12. Torque striker screws ③ to specification.

**TORQUE**

17 ft. lbs. (23 Nm) ± 10%

13. Torque striker nut ⑨ to specification.

**TORQUE**

54 ft. lbs. (73 Nm) ± 10%

14. Install LH accent panel ⑥ to door, engaging tabs in door with receptacles in panel, then secure using screw ⑤. Torque to specification.

**TORQUE**

18 in. lbs. (2.0 Nm) ± 10%

**NOTE**

Accent panel may be pre-installed from factory.

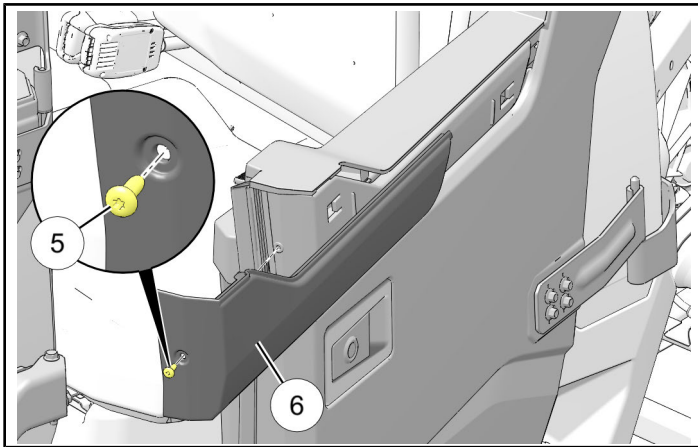

15. Repeat Steps 3–14 for RH door assembly ②, using upper RH chassis-side hinge ⑱, lower RH door-side hinge ⑲, RH B-pillar cover ⑳, RH striker bracket ㉑, and RH accent panel ㉒.

16. Lower vehicle bed.

**FEEDBACK FORM**

A feedback form has been created for the installer to provide any comments, questions or concerns about the installation instructions. The form is viewable on mobile devices by scanning the QR code or by clicking [HERE](#) if viewing on a PC.

**FEEDBACK FORM**

