

PLOW ANGLE CONTROL KIT

POLARIS

ENGINEERED PARTS
ACCESSORIES & APPAREL

P/N 2889032

APPLICATION

FOR USE WITH THE GLACIER PRO MID-SIZE PLOW SYSTEM P/N 2880260 ON THE BELOW LISTED MODELS:

- MY15 AND NEWER RZR 900 AND RZR S 900 MODELS (REQUIRES 2880836 PLOW CONTROL)
- MY10 AND NEWER MID-SIZE RANGER MODELS (REQUIRES 2879227 PLOW CONTROL)

BEFORE YOU BEGIN

Read these instructions thoroughly and make sure all parts and tools are accounted for. Please retain these installation instructions for future reference and parts ordering information.

IMPORTANT

The following instructions contain details required to install the contents of this kit and it should be used as a supplement to the plow system installation instructions. This kit requires a plow control kit and it is recommended that the plow control be installed in the vehicle prior to installing the angle kit. Please refer to the application listing to make certain you have the correct plow control for your application. The Glacier Pro Mid-Size Plow is a winch lift system so it is recommended that a winch be installed in the machine prior to installing this plow system.

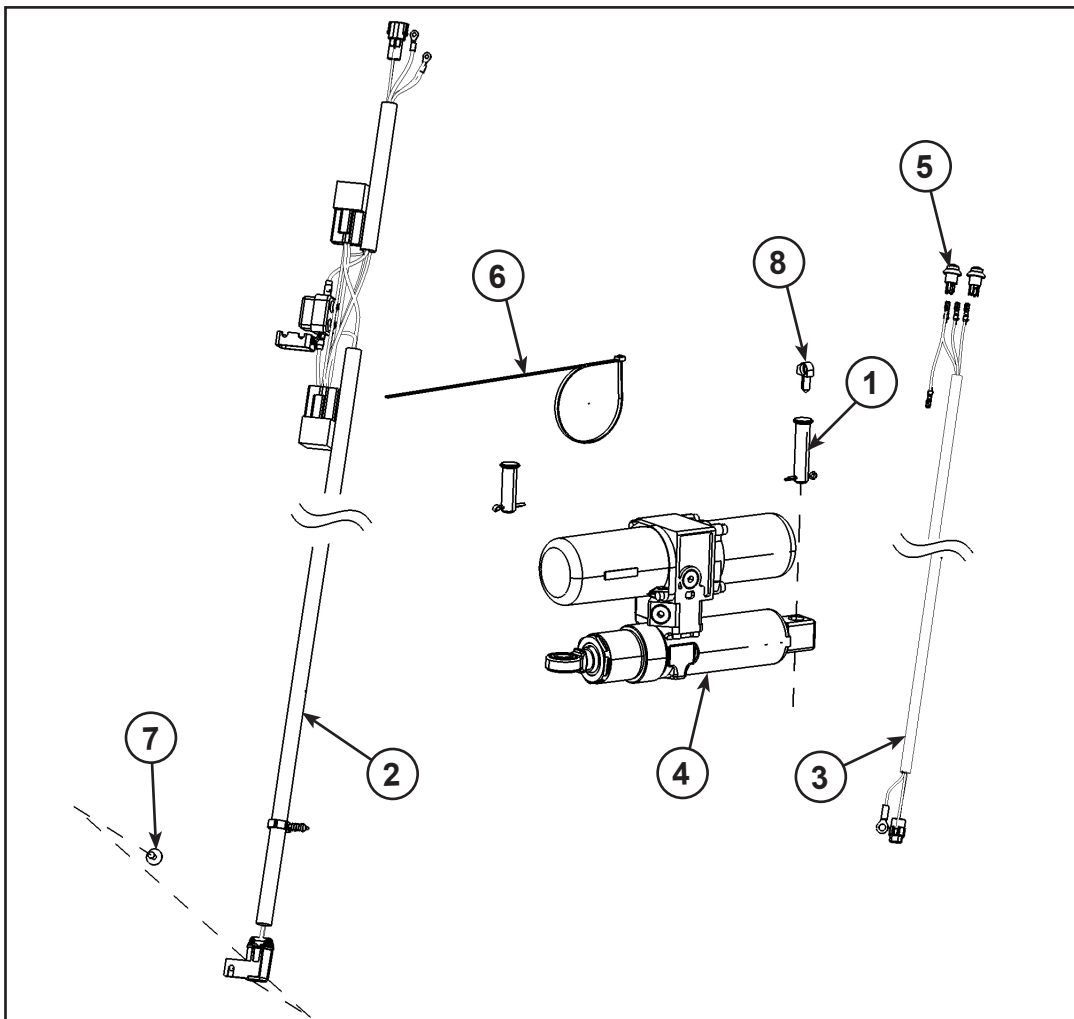

KIT CONTENTS

Ref	Qty	Part Description	Part Number
1	1	Hardware Kit	2205068
2	1	Harness-Plow	2412369
3	1	Harness-Plow Control	2412370
4	1	Angle Cylinder	2415814
5	2	Momentary Switch	4011501
6	5	Panduit Straps	7080492
7	1	Rivet	7621472
8	1	Routing Clip	7670102

TOOLS NEEDED

T-27 Torx Bit
Rivet Gun

Needle Nose Pliers
Metric Socket Set and Ratchet

Side Cutter

APPROXIMATE ASSEMBLY TIME

30 min

IMPORTANT

Your Polaris PLOW ANGLE CONTROL KIT is exclusively designed for your vehicle. Please read the installation instructions thoroughly before beginning. Installation is easier if the vehicle is clean and free of debris. For your safety, and to ensure a satisfactory installation, perform all installation steps correctly in the sequence shown.

INSTALLATION INSTRUCTIONS FOR MID-SIZE RANGER MODELS

1. Locate the battery and disconnect it prior to starting this installation. The battery can be found under the driver's seat on two passenger models or under the rear seat on crew models.
2. Use a T-27 torx bit to remove the stock grille insert from the bumper at this time retaining hardware for reuse.
3. Remove the protective cap (A) from the harness (2) and secure it to the left hand side of the grille (PN 5257056) with the rivet (7) as shown in figure. The grille insert (PN 5257056) can be found in the plow mount kit (PN 2880260). Clip the tabs holding the winch insert in place and remove it from the grille to make room for the winch fairlead.

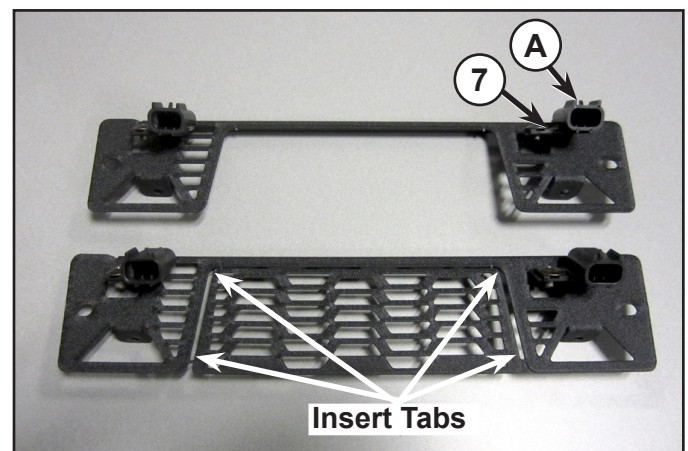

4. Follow the below instructions for proper wire routing:

- a) Please take note that this application will require the Plow Control Kit (PN 2879227). Please refer to the Plow Control Kit (PN 2879227) instructions for proper assembly of the plow controller. It is recommended that the Plow Control Kit be installed prior to installing this kit.
- b) Attach the red power (B) and black ground (C) leads of the plow harness (2) to the corresponding locations on the accessory terminal block as shown in figure. The accessory terminal block can be found under the hood just behind the dash on most models.
- c) Connect the white plug (D) on the plow harness to the mating connector found on the plow control harness that was previously installed and marked for use with the angle system.

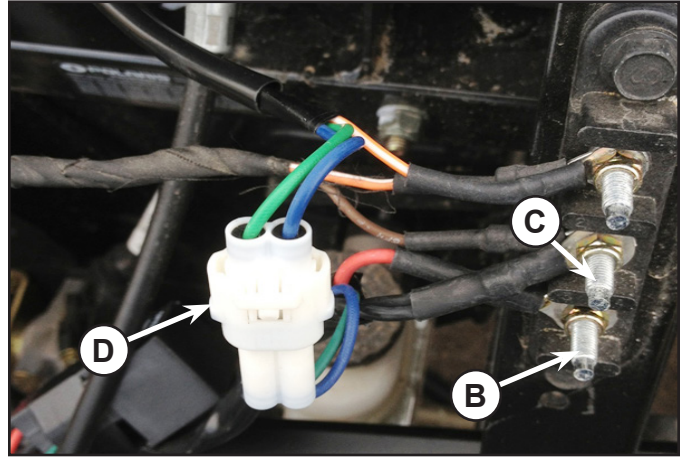

- d) Loop the plow harness (2) over the top of the strut support securing it in place with the provided Panduit straps (6) as shown in figure.
- e) Route the loose end of the plow control harness around the LH side of the radiator to the front of the unit.

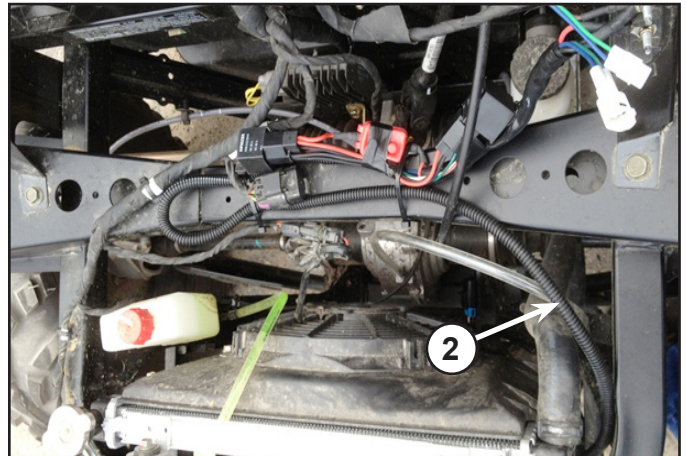

- f) From the front of the unit the harness plug should be routed through the left hand side of the bumper opening and pass through the left hand side of the grille insert (PN 5257056). The routing clip on the harness should be secured into the locating tab on the grille as showing in figure.
- g) Reinstall the grille insert at this time reusing the original mounting hardware.
- h) Check the wire routing making certain the harness does not make contact with sharp edges or pinch points that could damage the harness. Secure excess wire as necessary to prevent harness damage.

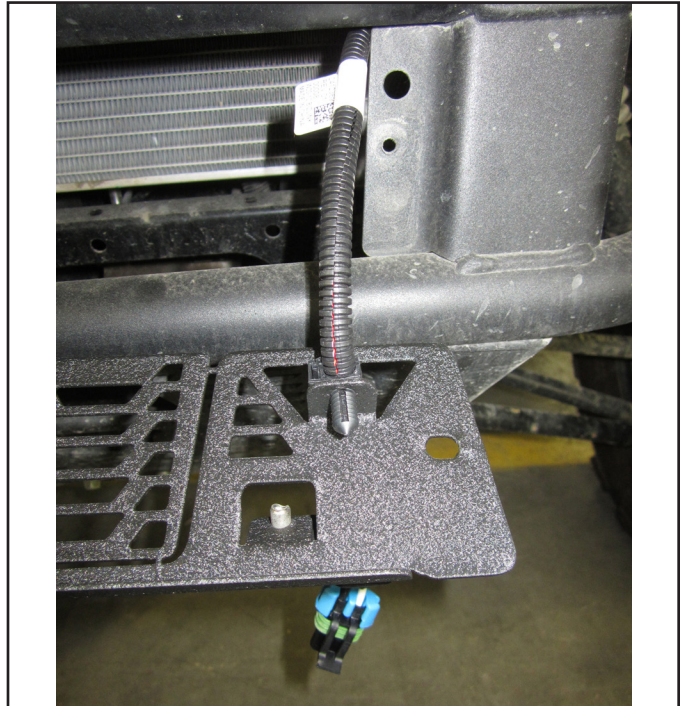

INSTALLATION INSTRUCTIONS FOR RZR 900 AND RZR S 900

1. Locate the battery and disconnect it prior to starting this installation. The battery can be found under the driver's seat on most models.
2. Remove the hood from the unit by releasing the $\frac{1}{4}$ turn latches, lift up on the rear of the hood to release the latches and pull the hood forward to disengage the front locking tabs.
3. Follow the below instructions for proper wire routing:

a) Please take note that this application will require the Plow Control Kit (PN 2880836). Please refer to the Plow Control Kit (PN 2880836) instructions for proper assembly of the plow controller. It is recommended that the Plow Control Kit be installed prior to installing this kit.

b) Attach the red power (B) and black ground (C) leads of the plow harness (2) to the corresponding locations on the accessory terminal block as shown in figure. The accessory terminal block can be found under the hood just behind the dash on most models.

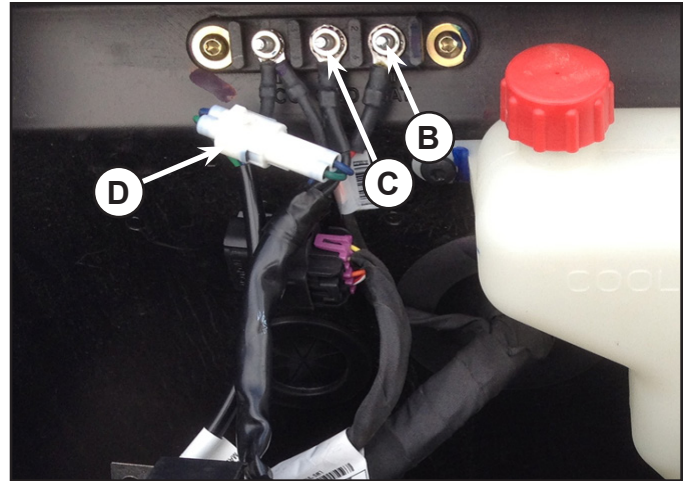

c) Connect the white plug (D) on the plow harness (2) to the mating connector found on the plow control harness that was previously installed and marked for use with the angle system.

d) Route the plow harness (2) from the accessory terminal block to the horizontal frame tube just above the front shock mounts as shown in figure. Secure the harness to the frame tube with three of the Panduit straps (6) provided in this kit.

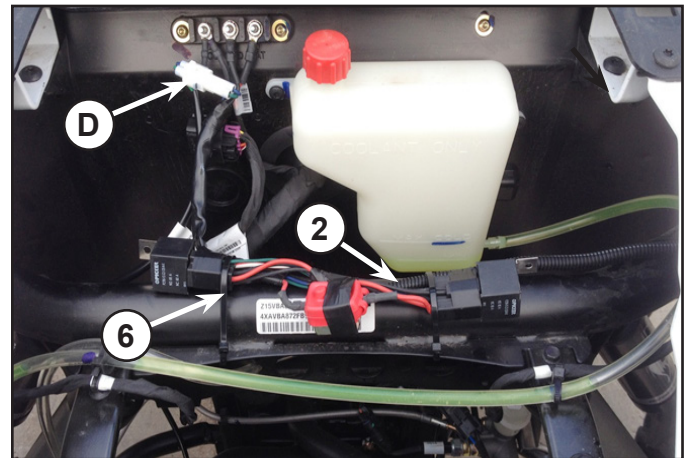

e) Route the plow harness (2) forward along the LH frame tube and through the wire routing hole (E) in the side or the radiator shroud as shown in figure. Secure the harness to the frame tube with two of the Panduit straps (6).

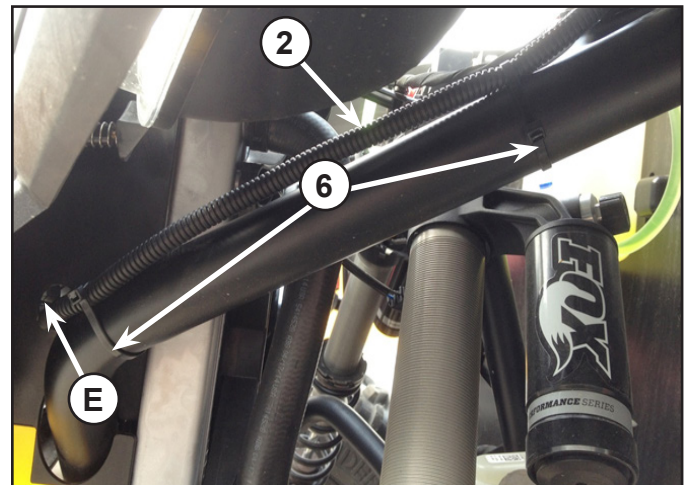

- f) Route the plow harness (2) between the plow mount bracket and the front plastic fascia. Secure the protective cap of the plow harness to the fascia as shown in figure.

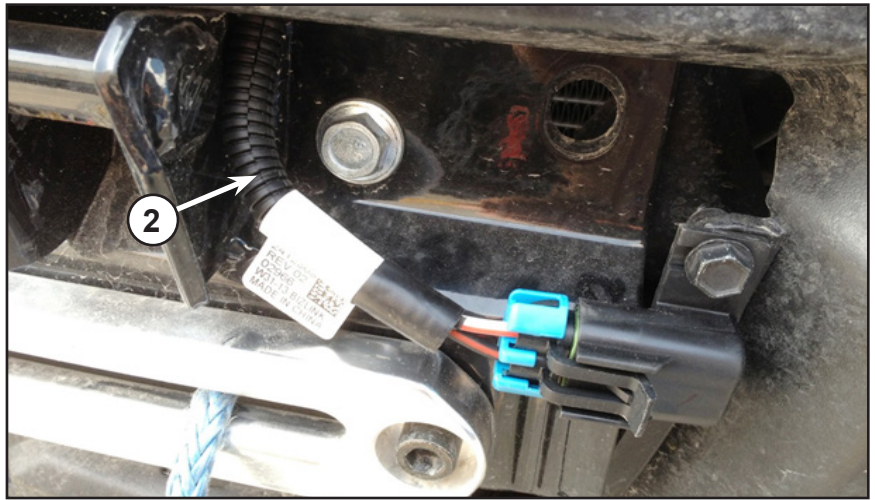

- g) Check the wire routing making certain the harness does not make contact with sharp edges or pinch points that could damage the harness. Secure excess wire as necessary to prevent harness damage.

ANGLE CYLINDER INSTALLATION

1. Locate the angle cylinder (4) and install the routing clip (8) 8.5" from the cylinder as shown in the figure.

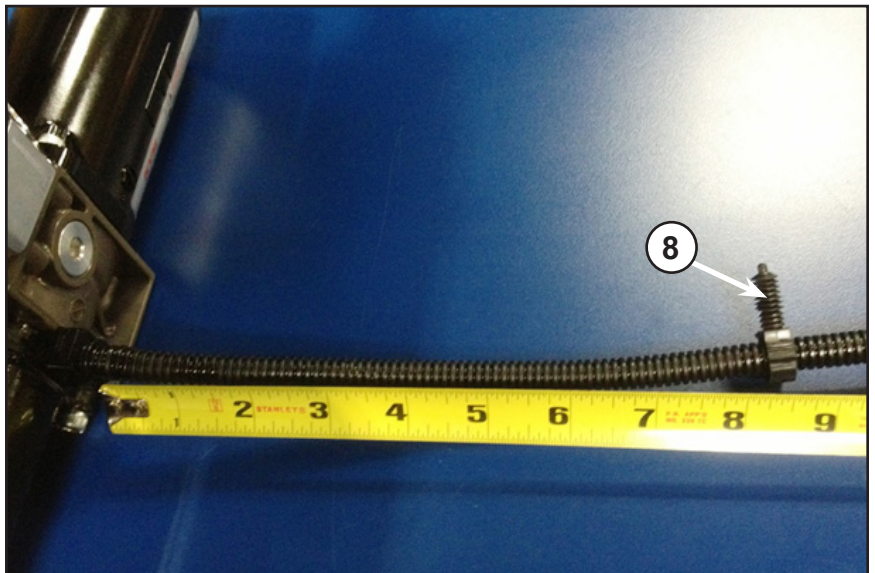

2. Remove the two pins (F) securing the stock angle locking arm (G) to the plow system and remove the assembly as shown in figure.

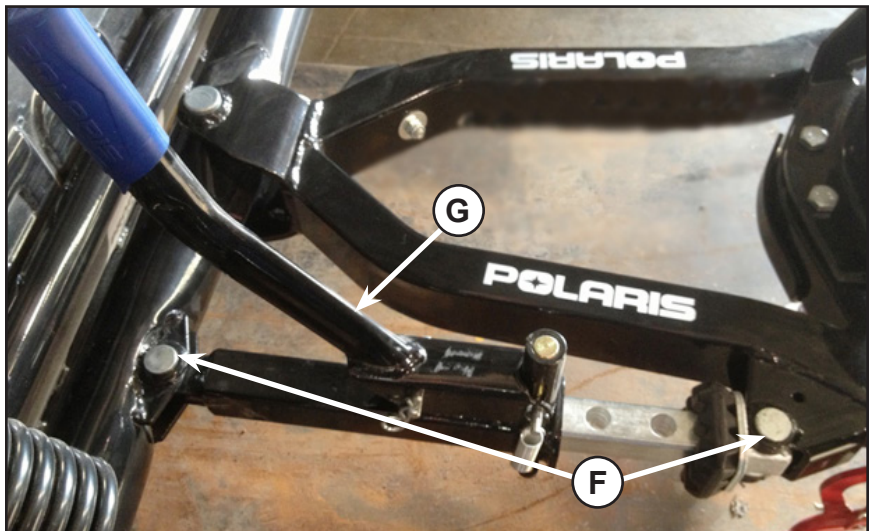

3. Install the cylinder (4) to the plow system using the new hardware provided in this kit. See the figure for proper orientation.
4. The power wires for the angle unit should exit the cylinder to the LH side of the plow frame and the routing clip (H) that was installed in Step 1 above should be pushed into the 1/4" hole on the left side of the plow frame as indicated in figure.

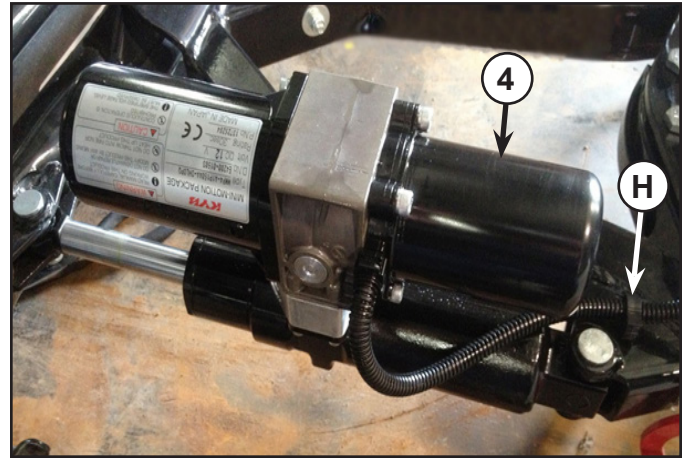

5. Reconnect the battery at this time.
6. Attach the plow system to the machine and connect the angle cylinder plug to the plow control harness.
7. Check operation to make sure the angle system functions properly.
8. Check wire routing to make sure wires have enough slack throughout the full range of plow motion. Verify the wires are free of pinch points or sharp edges that could damage the harness during operation.
9. When the plow system is removed from the unit the plow control wires should be connected to the cap installed on the unit to prevent moisture and debris from entering the plug as shown in figure.

