

LIGHT BAR HARNESS EXTENSION KIT



P/N 2883854

APPLICATION

Verify accessory fitment at Polaris.com.

BEFORE YOU BEGIN

Read these instructions and check to be sure all parts and tools are accounted for. Please retain these installation instructions for future reference and parts ordering information.

KIT CONTENTS

This kit contains parts for installation of the Light Bar Harness Extension only. Prior installation of the following additional items is also required (sold separately):

- Single Light Bar Harness Kit, PN 2883230 (or equivalent)
- Light Bar Kit (multiple PNs available)

This Kit includes:

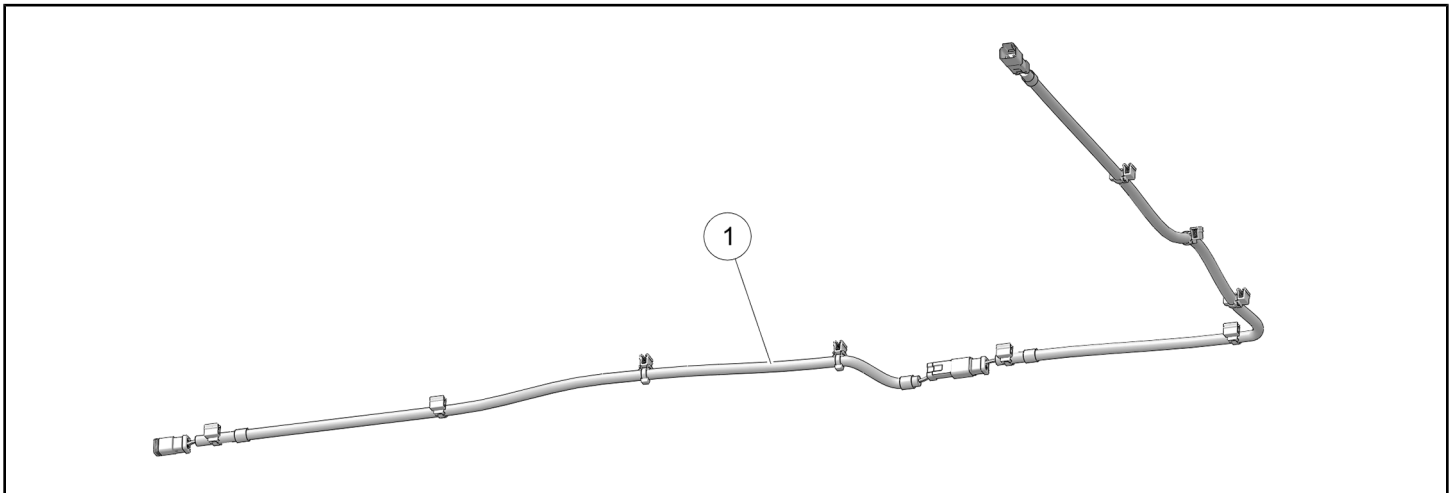

REF	QTY	PART DESCRIPTION	PART NUMBER
1	1	Harness, Extension, Light Bar	-
	1	Instructions	9929092

TOOLS REQUIRED

- Safety Glasses

IMPORTANT

Your Light Bar Harness Extension Kit is exclusively designed for your vehicle. Please read the installation instructions thoroughly before beginning. Installation is easier if the vehicle is clean and free of debris. For your safety, and to ensure a satisfactory installation, perform all installation steps correctly in the sequence shown.

ASSEMBLY TIME

Approximately 5 minutes

NOTE

Additional time may be required to accommodate other accessories.

HARNESS DETAIL

EXTENSION HARNESS ①:

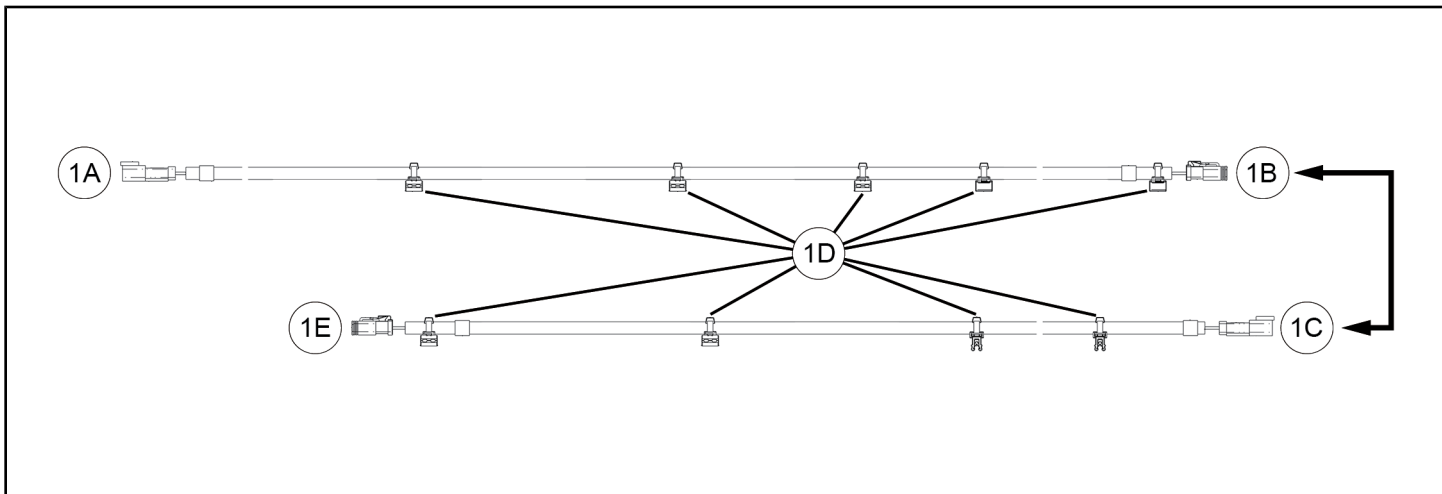

REF	PART DESCRIPTION	WIRE COLOR	PIN QTY/ GENDER	CONNECTS TO
1A	Connector (identified as: LIGHT BAR)	-	2 male	Single Light Bar Harness Kit, PN 2883230 (or equivalent)
1B	Connector (identified as: WORK LIGHT (BASE))	-	2 female	PRE-CONNECTED to 1C
1C	Connector (identified as: CREW EXTENSION)	-	2 male	PRE-CONNECTED to 1B
1D	Clip, Edge	-	-	Vehicle structure
1E	Connector (identified as: WORK LIGHT (CREW))	-	2 female	Light bar kit (sold separately)

INSTALLATION INSTRUCTIONS

This light bar harness extension is designed to provide power to a light bar (work light) installed at the rear of the roof.

- As shipped, the length will reach to the rear of the *RANGER CREW*® XP.
 - If the rear harness segment is detached the length will reach to the rear of the (non-crew) *RANGER XP*®.
1. Shift vehicle transmission into "PARK". Turn ignition switch to "OFF" position and remove key.
 2. If installed, remove front (and rear, if applicable) roof liner(s) to gain access to lower side of roof.
 3. Join "**LIGHT BAR**" connector 1A on extension harness ① to "**LIGHT BAR**" connector (A) on previously installed Single Light Bar Harness (PN 2883230 or equivalent; sold separately).

NOTE

See previous section, **HARNESS DETAIL**, for connector identification.

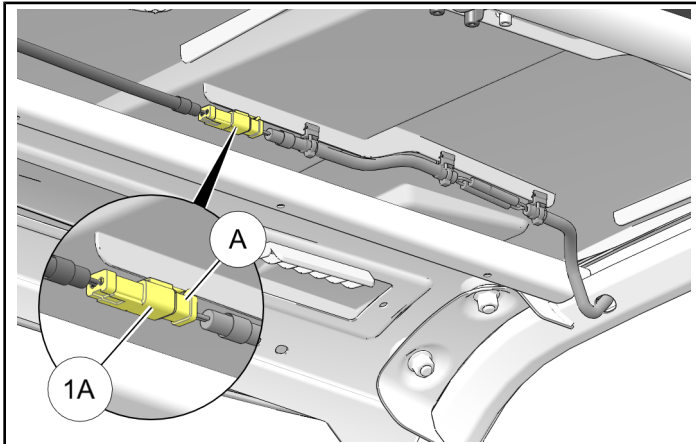

4. Route extension harness ① to LH side of roof, then rearward along ROPS.

IMPORTANT

Do NOT secure harness to roof until all electrical connections are made.

- **CREW** vehicles: Route harness over top of B-pillar cross-member, then join "**WORK LIGHT (CREW)**" connector 1E to light bar.
- **NON-CREW** vehicles: Detach "**CREW EXTENSION**" connector 1C from "**WORK LIGHT (BASE)**" connector 1B, then join connector 1B to light bar.

Detached rear harness segment is not used.

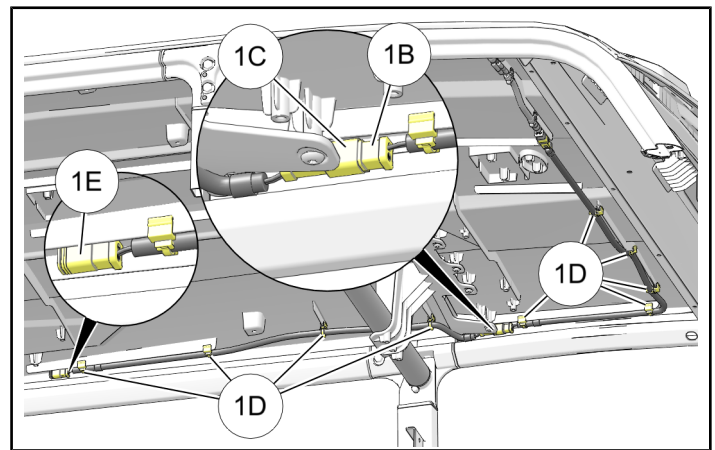

5. Secure extension harness ① to roof using five edge clips 1D on front harness segment, and if installing on crew vehicles, four additional edge clips 1D on rear harness segment.

FEEDBACK FORM

A feedback form has been created for the installer to provide any comments, questions or concerns about the installation instructions. The form is viewable on mobile devices by scanning the QR code or by clicking [HERE](#) if viewing on a PC.

FEEDBACK FORM

