

WIRELESS REMOTE KIT



P/N 2883455

APPLICATION

Verify accessory fitment at Polaris.com.

IMPORTANT

This Wireless Remote Kit is intended for use with HD 4500 Lb. Winch Kit (PN 2882714).

BEFORE YOU BEGIN

Read these instructions and check to be sure all parts and tools are accounted for. Please retain these installation instructions for future reference and parts ordering information.

KIT CONTENTS

This Kit includes:

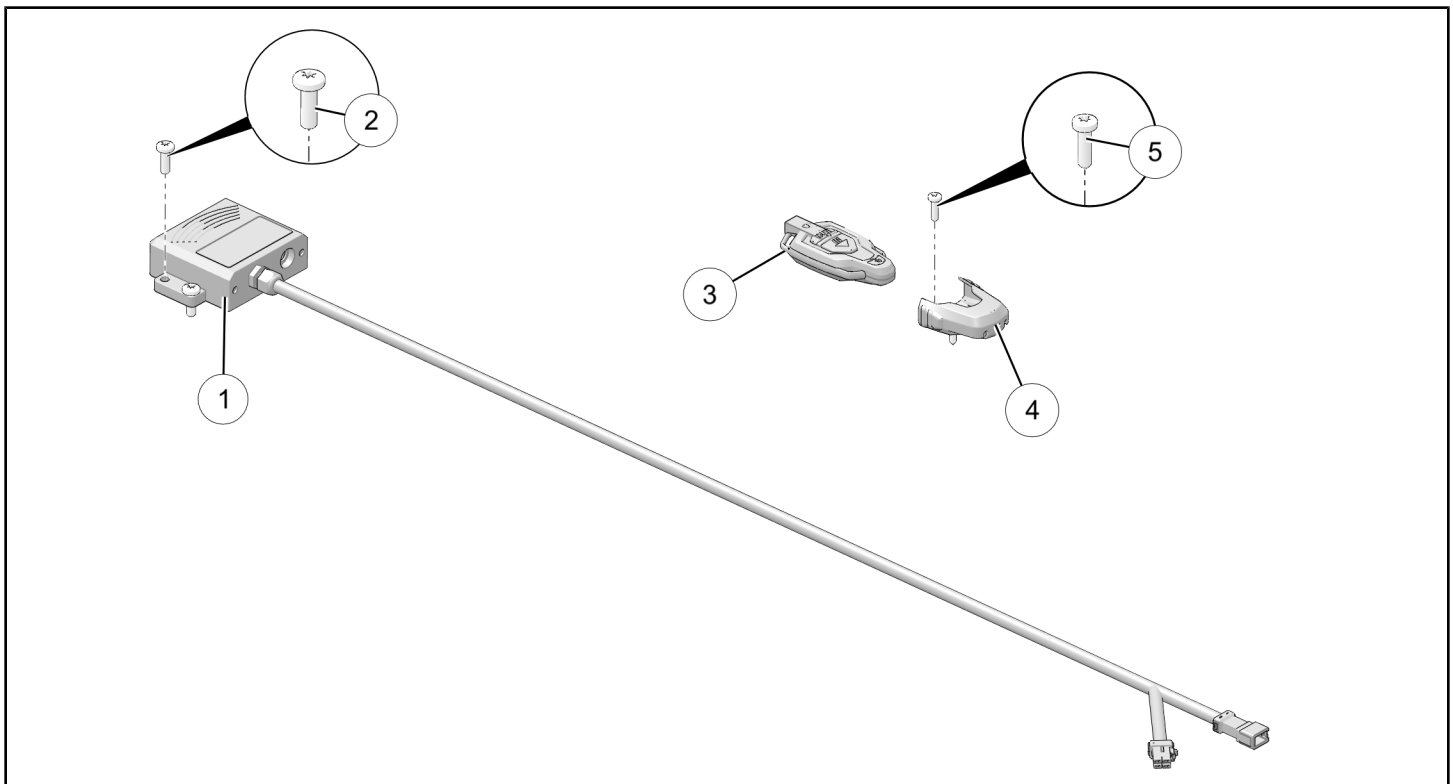

REF	QTY	PART DESCRIPTION	PART NUMBER
1	1	Receiver, Wireless	-
2	4	Screw, Torx® Pan Head, High/Low - #14 X 0.75	7519731
3	1	Remote, Wireless	-
4	1	Holder, Wireless Remote	-
5	2	Screw, Torx® Pan Head, High/Low - #10 X 0.75	7512026
	1	Instructions	9929286

TOOLS REQUIRED

- Safety Glasses
- Drill
- Drill Bit: 1/8 inch (3 mm)
- Pliers, Push Pin Rivet
- Screwdriver Set, Torx®
- Socket Set, Metric
- Wrench Set, Metric

IMPORTANT

Your Wireless Remote Kit is exclusively designed for your vehicle. Please read the installation instructions thoroughly before beginning. Installation is easier if the vehicle is clean and free of debris. For your safety, and to ensure a satisfactory installation, perform all installation steps correctly in the sequence shown.

ASSEMBLY TIME

Approximately 20–30 minutes

NOTE

Additional time may be required for optional step, or to accommodate other accessories.

HARNESS DETAIL

WIRELESS RECEIVER ①:

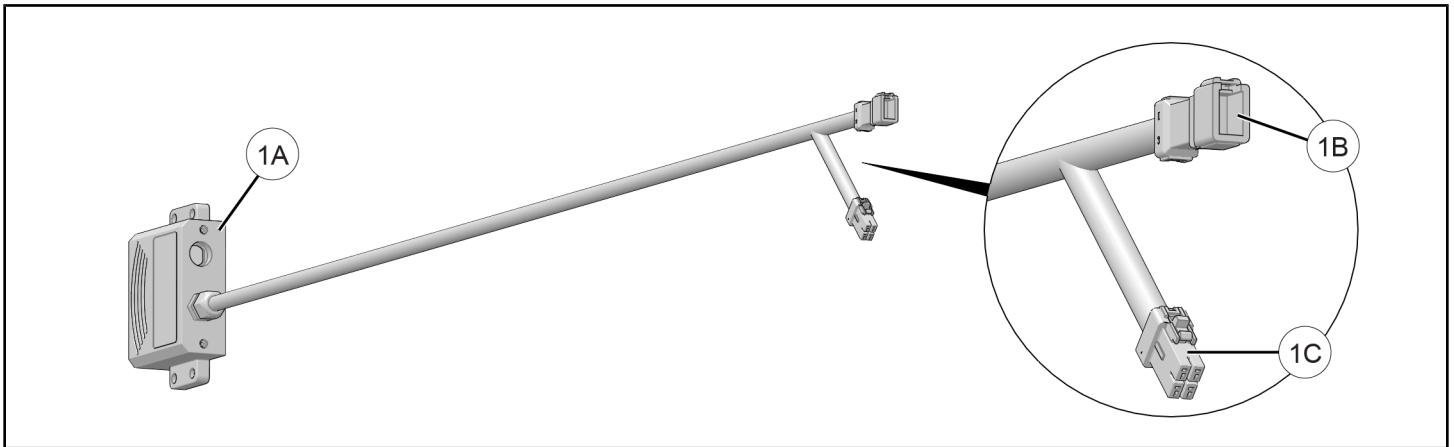

REF	PART DESCRIPTION	WIRE COLOR	PIN QTY/ GENDER	CONNECTS TO
1A	Wireless Receiver	-	-	Vehicle structure
1B	Connector, Autostop Controller/ Contactor	-	4 male	Main vehicle harness breakout; see instructions for detail
1C	Connector, Wired Remote	-	4 female	Wired remote socket; see instructions for detail

INSTALLATION INSTRUCTIONS

- Shift vehicle transmission into "PARK". Turn ignition key to "OFF" position and remove from ignition switch.
- Flip up passenger seat bottom, remove driver's seat and underseat storage compartment, then disconnect black negative (-) cable from battery.
- Gain access.
 - Remove hood.
 - Remove upper dash cupholder by removing two push pin rivets **A**, then sliding cupholder rearward. Retain rivets.

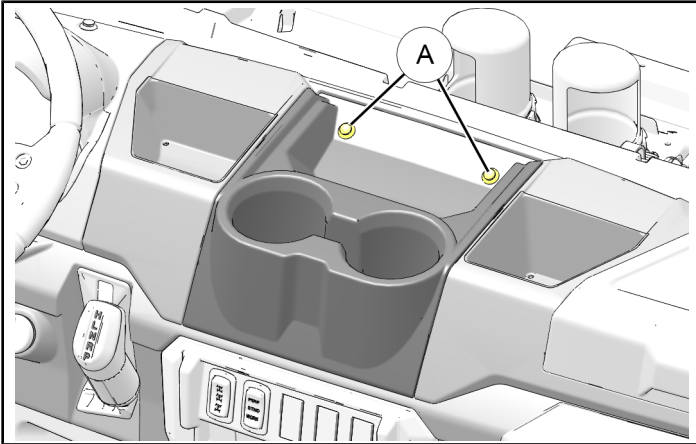

- Install wireless receiver.
 - Install wireless receiver **1** to RH side of underhood liner using four screws **2**. Do not over-tighten screws.

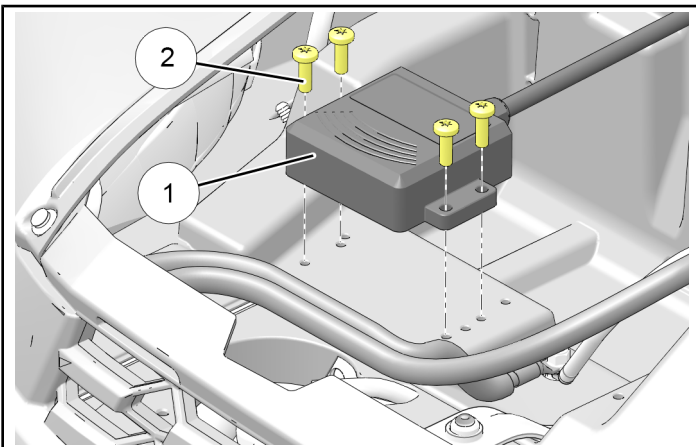

- Route wireless receiver connectors 1B and 1C rearward through firewall grommet into upper dash compartment.

NOTE

See previous section, **HARNES DETAIL**, for connector identification.

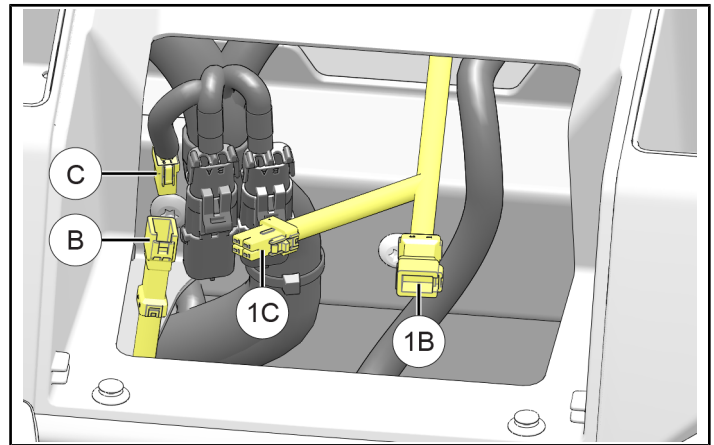

- Detach existing wired remote connector **B** from main vehicle harness breakout connector **C**.
- Join wired remote connector **B** to wireless remote connector 1C.
- Join wireless remote connector 1B to main vehicle harness breakout connector **C**.

- OPTIONAL: Install wireless remote.

NOTE

Wireless remote can be stowed in any suitable location. Holder **4** is not required.

- Remove wireless remote **3** from holder **4**. Determine suitable mounting location for holder with special attention to the following:
 - Driver operation of vehicle (including travel of controls, such as shift lever)
 - Driver visibility
 - Adequate clearance between holder mounting fasteners and other vehicle components on underside of mounting surface
- Using holder **4** as template, mark and drill two 1/8 inch (3 mm) holes into mounting surface.

IMPORTANT

Control drill depth to prevent damage to underlying structure or components.

- Install holder **4** using two screws **5**. Do not over-tighten screws.
 - Reinstall wireless remote into holder.
- Restore access. See Step 3.
 - Reconnect black negative (-) cable to battery, then reinstall under-seat storage compartment and driver's seat.

OPERATION

OPERATIONAL CHECK

Wireless remote allows winch operation from outside the vehicle. If winch does not operate as described, refer to the **TROUBLESHOOTING** section.

IMPORTANT

The winch operator is always responsible for using the winch properly, as described in the “Winch User Guide” included in the winch kit.

1. To turn wireless remote “ON”, depress and hold power button for three seconds or until LED light illuminates.
2. To extend rope, depress and hold the “OUT” button. To recover rope, depress and hold the “IN” button.

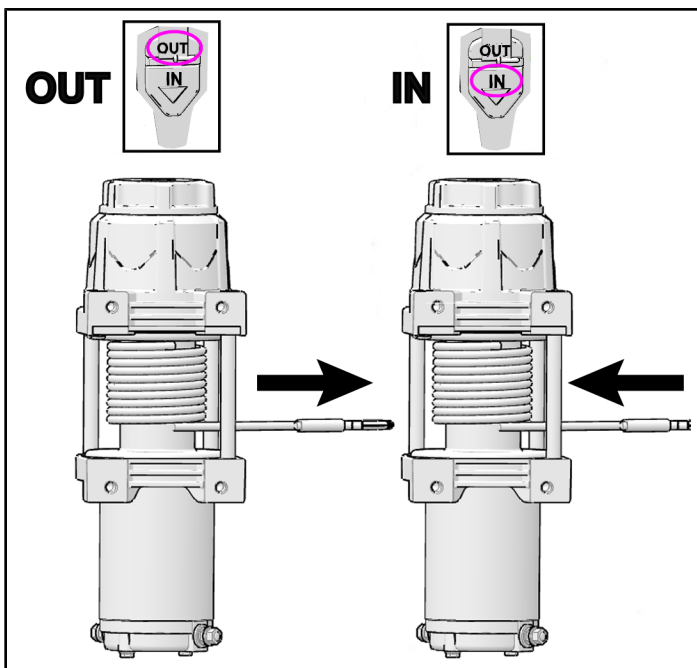

3. The wireless remote will automatically turn “OFF” after 30 seconds of inactivity. To manually turn off, depress and hold power button for three seconds or until LED light extinguishes.

TROUBLESHOOTING

SYMPTOM	POSSIBLE CAUSES	RECOMMENDED SOLUTION
Dead vehicle battery	Incorrect, damaged, or corroded electrical connections	Verify all winch electrical connections are per instruction manual and free of damage and/or corrosion.
Winch will not operate	Contactors not receiving power	Turn vehicle key on.
	Wireless remote not powered on	Turn wireless remote on.
	Incorrect, damaged, or corroded electrical connections	Verify all winch electrical connections are per instruction manual and free of damage and/or corrosion.
	Keyed power circuit (orange wires) not properly powered	Check 10A accessory circuit fuse for continuity; replace as required.
Winch operates in one direction only	Autostop fairlead not properly connected	If winch operates only outward then ensure magnetic stop (black rubber puck) is not touching autostop fairlead. If winch operates inward even when magnetic stop is touching fairlead then verify all winch electrical connections are per instruction manual and free of damage and/or corrosion.
Winch makes noise but rope/cable does not move	Contactors powered, but not winch	If clicking sound is heard when winch control button is depressed, but winch motor is silent, then verify electrical connections between winch and contactors are free of damage and/or corrosion. If winch makes noise but does not move, verify winch is in gear. If winch is in gear, but winch still does not move, have a dealer inspect the winch.
Winch operates too slowly	Winch is improperly loaded	Verify rope/cable is not binding on spool or fairlead.
Winch will not change gears	Rope/cable is under load	Changing gears while under load is intentionally difficult to prevent accidental operation, which could lead to personal injury or winch failure. Ensure rope/cable is under no tension, and rope/cable is not binding on spool or fairlead. Briefly operate winch, then attempt to shift again.

FEEDBACK FORM

A feedback form has been created for the installer to provide any comments, questions or concerns about the installation instructions. The form is viewable on mobile devices by scanning the QR code or by clicking [HERE](#) if viewing on a PC.

FEEDBACK FORM

