

WINDSHIELD WIPER KIT



P/N 2883974

BEFORE YOU BEGIN

Read these instructions and check to be sure all parts and tools are accounted for. Please retain these installation instructions for future reference and parts ordering information.

REQUIRED, SOLD SEPARATELY

This kit only contains parts for installation of the Windshield Wiper Kit. Prior installation of the following additional kits is also required (sold separately):

1. One of the following windshield kits:
 - Glass Lock & Ride® Windshield Kit, PN 2882191
 - Glass Tip-Out Windshield Kit, PN 2882874
 - Other compatible windshield kit
2. One of the following roof kits:
 - Premium Roof Kit, PN 2882912 (black) or 2882913 (camo)
 - Poly Roof Kit, PN 2882911
 - Other compatible roof kit

KIT CONTENTS

This Kit includes:

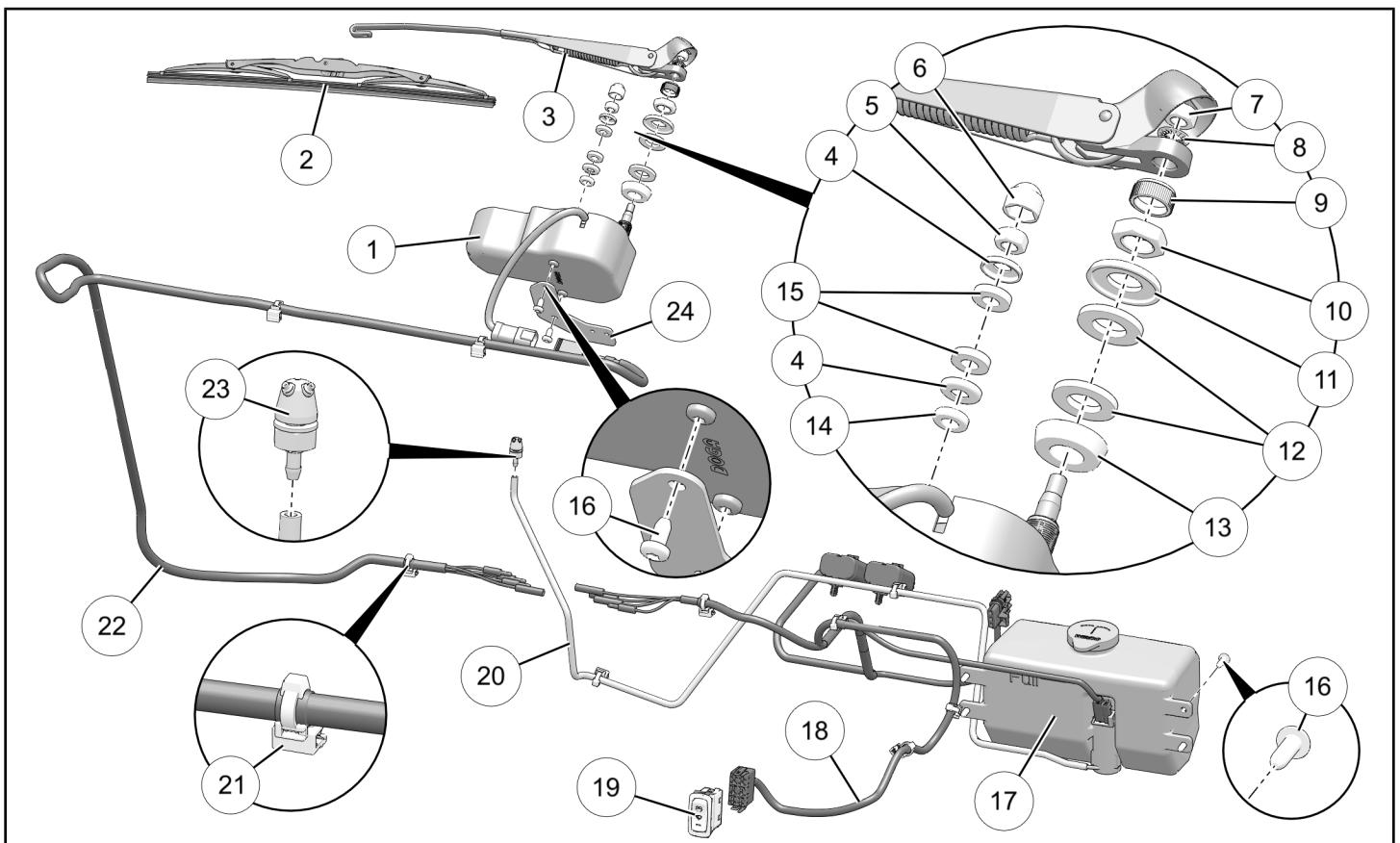

REF	QTY	PART DESCRIPTION	PART NUMBER	INCLUDED IN SERVICE KIT
1	1	Motor Assembly	2637637	-
2	1	Blade, Wiper	2637635	-
3	1	Arm, Wiper	2637636	-
4	2	Washer, Plastic, Cupped, Small	-	2208226
5	1	Nut, Hex - M6 x 1.25	-	2208226
6	1	Cap	-	2208226
7	1	Nut, Hex - M8	-	2208225
8	1	Washer, Internal Tooth Lock	-	2208225
9	1	Cap	-	2208225
10	1	Nut, Hex - M16 X 1.0	-	2208225
11	1	Washer, Plastic, Cupped, Large	-	2208225
12	2	Washer, Rubber, Flat	-	2208225
13	1	Spacer, Support	-	2208225
14	1	Bushing	-	2208226
15	2	Washer, Plastic, Flat	-	2208226
16	6	Screw, Torx® Truss Head, High/Low - #14 X 3/4	7519045	-
17	1	Bottle Assembly, Washer (includes pump, pump grommet, and bottle cap)	-	2205139
18	1	Harness, Power	2414864	-
19	1	Switch, Wiper/Washer	4018701	-
20	1	Hose, Washer Bottle	5417098	-
21	9	Clip, Edge	7082365	-
22	1	Harness, ROPS	2414865	-
23	1	Nozzle Assembly (includes nut and washer)	2637660	-
24	1	Bracket, Rear View Mirror Accessory	5268630-458	-
25	4	Cable Tie (not shown)	7080492	-

TOOLS REQUIRED

- Safety Glasses
- Drill
- Drill Bit: 9/32 inch (7 mm), 5/16 inch (8 mm), 3/4 inch (19 mm)
- Pliers, Push Pin Rivet
- Screwdriver Set, Torx®
- Socket Set, Metric
- Torque Wrench
- Wrench Set, Metric

IMPORTANT

Your Windshield Wiper Kit is exclusively designed for your vehicle. Please read the installation instructions thoroughly before beginning. Installation is easier if the vehicle is clean and free of debris. For your safety, and to ensure a satisfactory installation, perform all installation steps correctly in the sequence shown.

HARNESS DETAIL

POWER HARNESS ⑱:

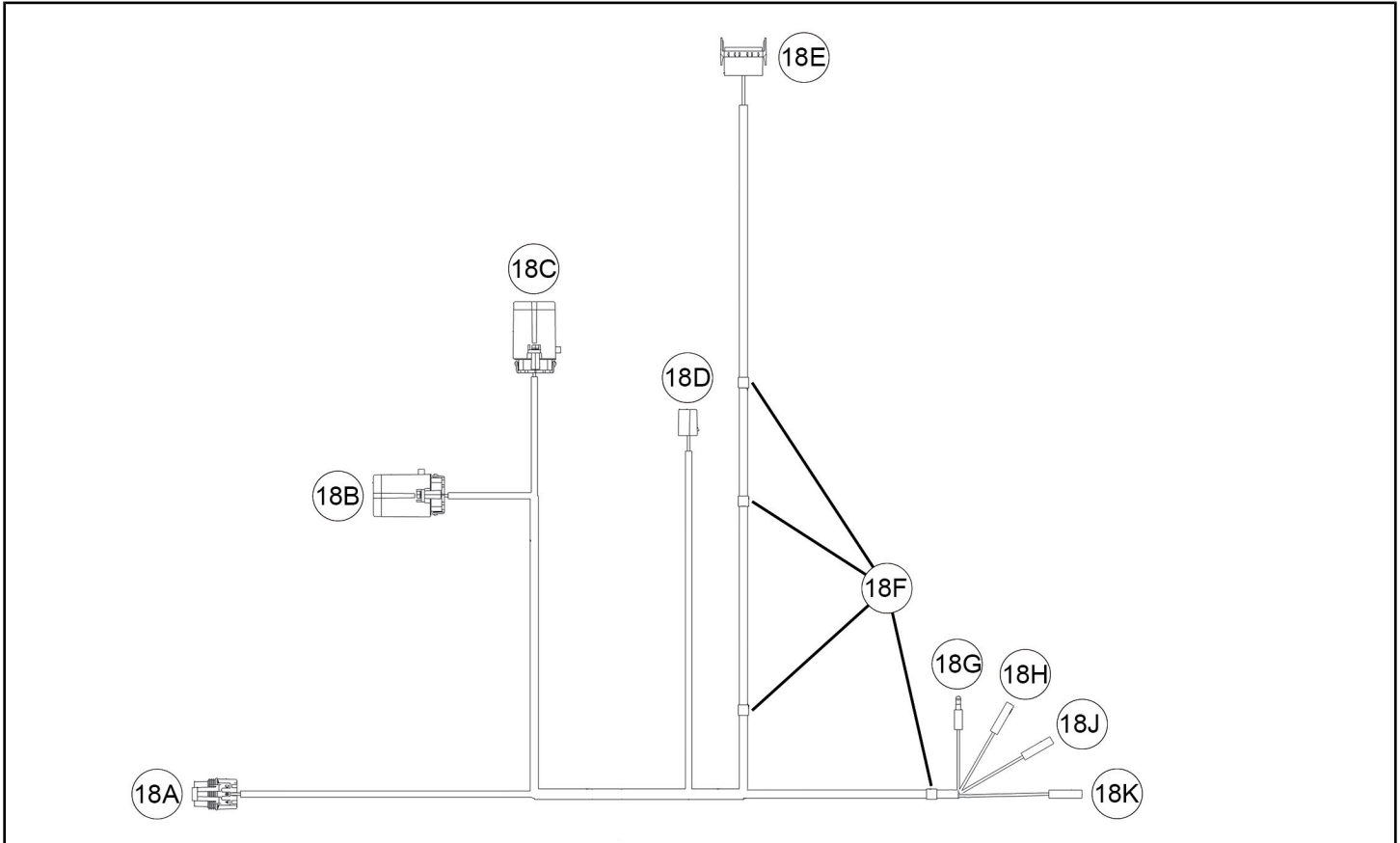

REF	PART DESCRIPTION	WIRE COLOR	PIN QTY/ GENDER	CONNECTS TO
18A	Connector, Terminal Block	-	3 female	Pulse™ terminal block
18B	Relay/Circuit Breaker, Switched Power	-	-	Vehicle structure
18C	Relay, Park	-	-	Vehicle structure
18D	Connector, Fluid Pump	-	2 female	Washer bottle assembly ⑰
18E	Connector, Switch	-	12 female	Switch ⑲
18F	Tape, White (4 places)	-	-	Identifies installation location for edge clip ⑳
18G	Connector, Bullet, Wiper Motor, Ground	Black	1 male	ROPS harness ㉒, connector 22A
18H	Connector, Bullet, Wiper Motor, Operation	Red	1 female	ROPS harness ㉒, connector 22B
18J	Connector, Bullet, Wiper Motor, Park	Green	1 female	ROPS harness ㉒, connector 22C
18K	Connector, Bullet, Wiper Motor, B+ Switched	Yellow	1 female	ROPS harness ㉒, connector 22D

ROPS HARNESS ⑫:

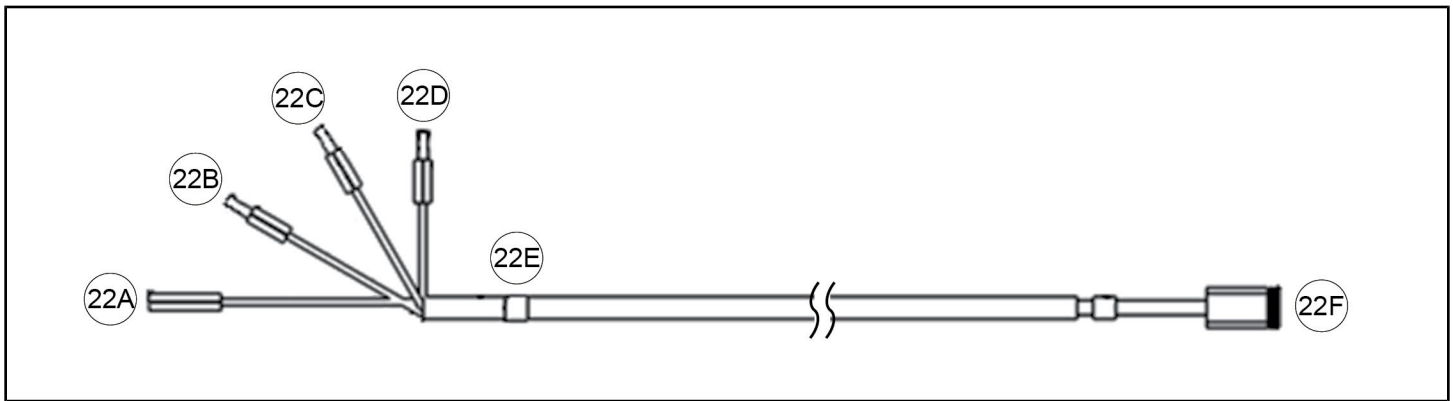

REF	PART DESCRIPTION	WIRE COLOR	PIN QTY/ GENDER	CONNECTS TO
22A	Connector, Bullet, Wiper Motor, Ground	Black	1 female	Power harness ⑱, connector 18G
22B	Connector, Bullet, Wiper Motor, Operation	Red	1 male	Power harness ⑱, connector 18H
22C	Connector, Bullet, Wiper Motor, Park	Green	1 male	Power harness ⑱, connector 18J
22D	Connector, Bullet, Wiper Motor, B+ Switched	Yellow	1 male	Power harness ⑱, connector 18K
22E	Tape, White Identification	-	-	Identifies installation location for edge clip ⑳
22F	Connector, Wiper Motor (identified as: WIPER)	-	4 female	Motor assembly ①

INSTALLATION INSTRUCTIONS

- Shift vehicle transmission into "PARK". Turn ignition switch to "OFF" position and remove key.

⚠ WARNING

Ensure red positive (+) battery terminal is **COMPLETELY COVERED** by protective boot. Accidental tool contact across both battery terminals will result in high current electrical arc, and may result in battery explosion. Death or serious personal injury may occur.

- Flip up passenger seat bottom (**RANGER CREW**®: right rear passenger seat bottom) and remove underseat storage compartment. Disconnect black negative (-) cable from battery.
- Remove hood.

- Remove roof liner (if installed).
 - Remove rear (roof mounted) speakers, if installed.
 - Remove seven push darts (A) from rear liner, two from rear edge and five from front edge. Retain push darts.

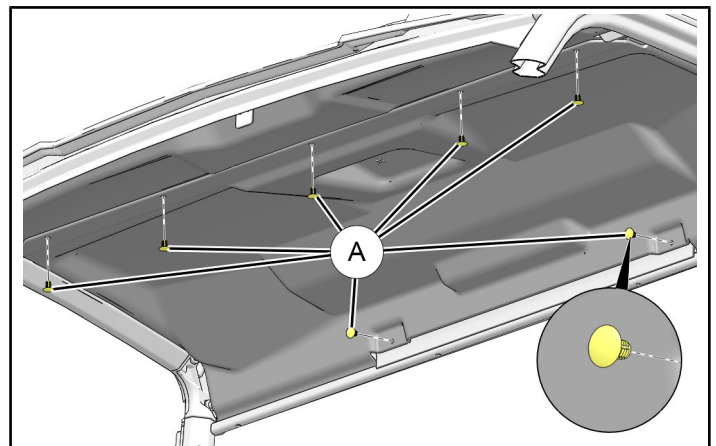

- c. If light is installed against rear liner, remove it. Otherwise, remove two each screws (B) and washers (C). Retain hardware.

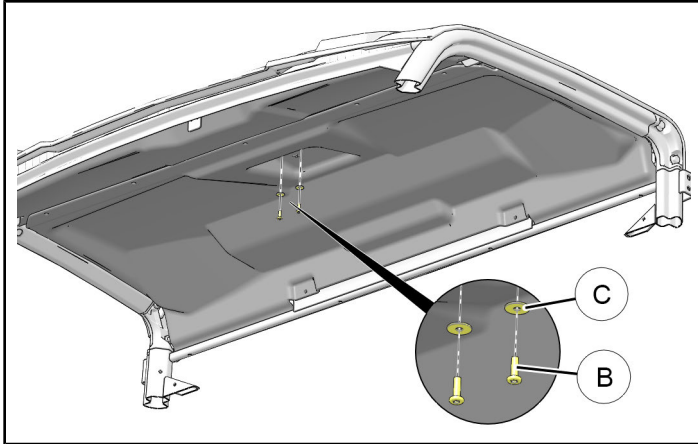

- d. Carefully pull LH and RH edges of rear liner from between ROPS and roof seal, then remove rear edge of liner from roof support channel (D).

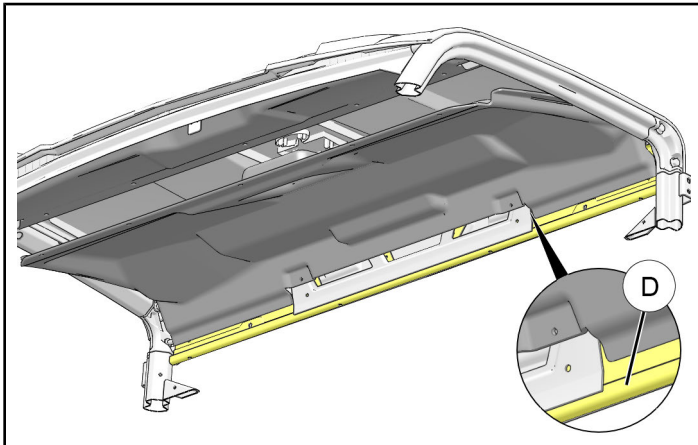

- e. Remove front roof liner by removing two each screws (E) and washers (F). Retain hardware.

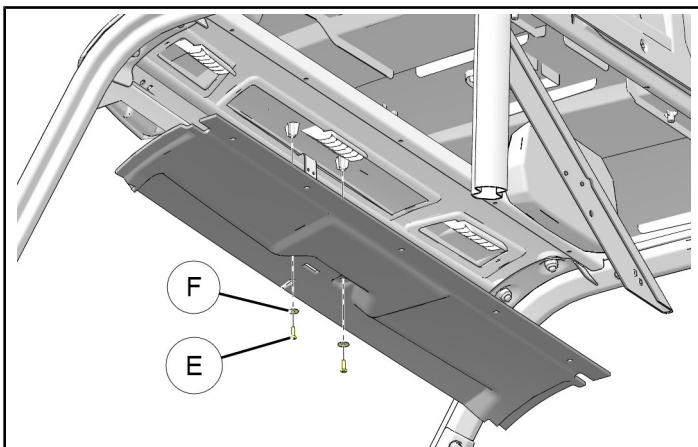

5. Gain access to dash interior.

RANGER XP® 1000, RANGER CREW® XP 1000

- a. Remove upper dash cupholder by removing two push pin rivets (G), then slide cupholder rearward. Retain rivets.

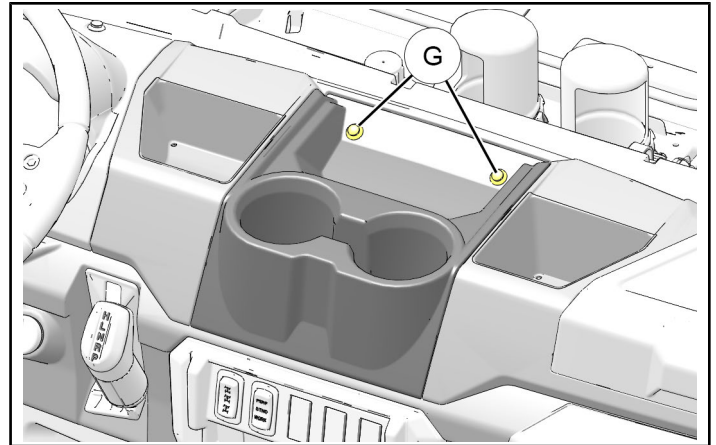

- b. Tilt steering wheel to full down position. Detach instrument cluster hood by removing two push pin rivets (H), then slide hood (with instrument cluster) rearward. Disconnect instrument cluster wiring harness. Retain rivets.

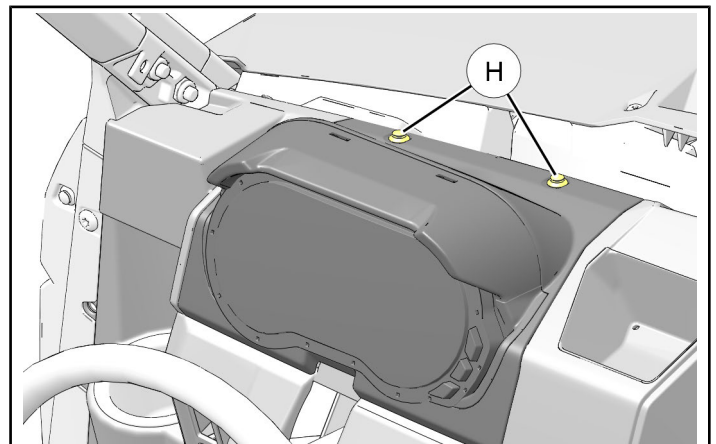

RANGER® 1000, RANGER CREW® 1000

- a. If windshield is installed, remove or open (as applicable) to gain access to upper dash.
- b. Remove upper dash cupholder by removing two push pin rivets (G), then slide cupholder rearward. Retain rivets.

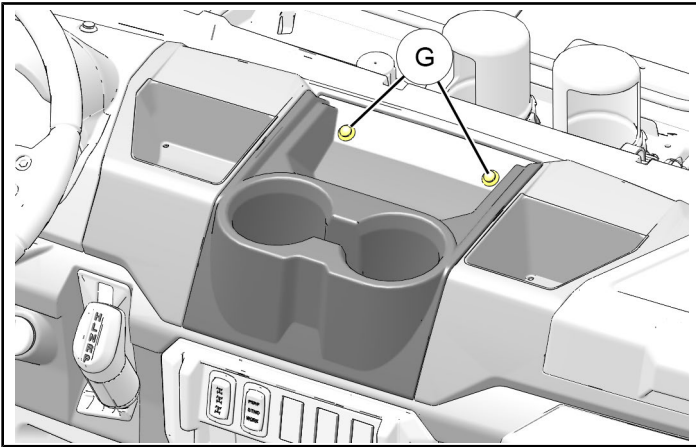

- c. Remove six push pin rivets (J) along forward edge of dash.

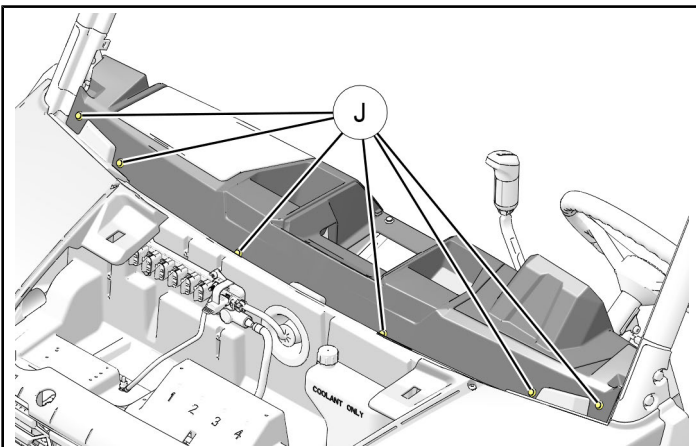

- d. Remove five push pin rivets (K) from LH side of dash: two at center cupholder, two below instrument cluster, and one on underside of dash above cupholder.

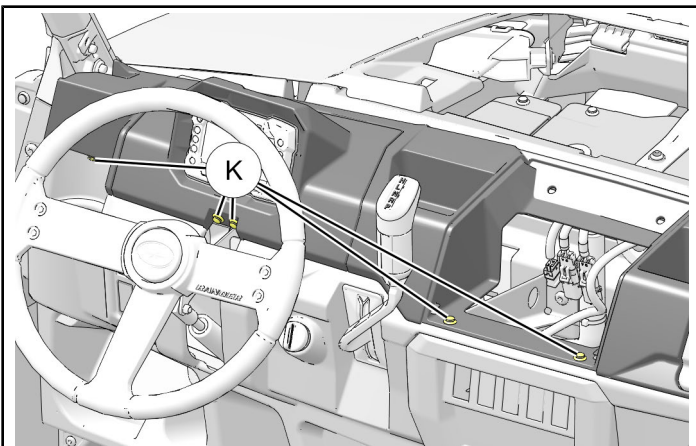

- e. Open door to upper storage compartment. Remove three push pin rivets (L) from RH side of dash: two inside storage compartment and one on underside of dash above cupholder.

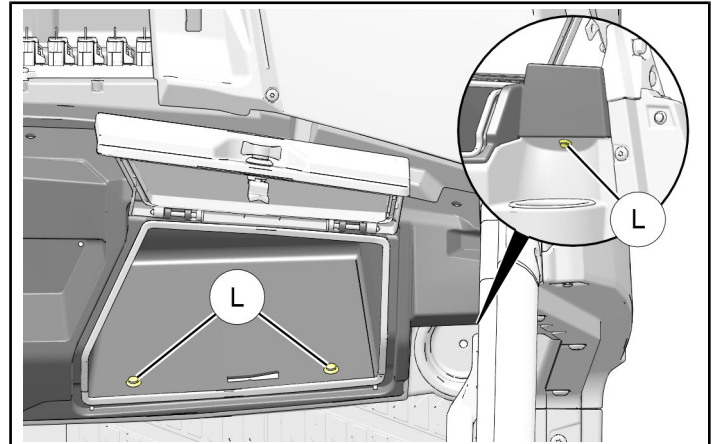

- f. Remove upper dash from vehicle.

6. Install windshield wiper housing assembly.

NOTE

Windshield should remain installed and locked for this step.
Glass Lock & Ride® Windshield shown; Glass Tip-Out Windshield similar.

- a. Using windshield attach plate (M) as template, drill two holes from inside of vehicle forward through plastic trim:
 - Wiper motor shaft (N): 3/4 inch (19 mm) diameter hole
 - Anti-rotation stud (P): 9/32 inch (7 mm) diameter hole

NOTE

Holes in metal attach plate are not enlarged. Drill only through plastic trim.
Motor assembly shown for reference only. Installation will occur in Step c. below.

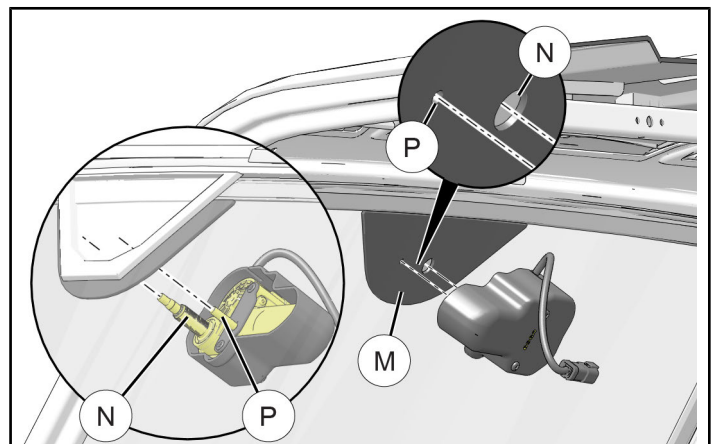

b. Install the following items to motor assembly

①:

- **Wiper motor shaft (N)**: spacer (13) and rubber washer (12). Ensure spacer is installed with SMALL outside diameter towards motor as shown (large outside diameter towards windshield).
- **Anti-rotation stud (P)**: bushing (14), small cupped plastic washer (4), and flat plastic washer (15). Ensure flat washer (15) nests inside cupped washer (4) as shown.

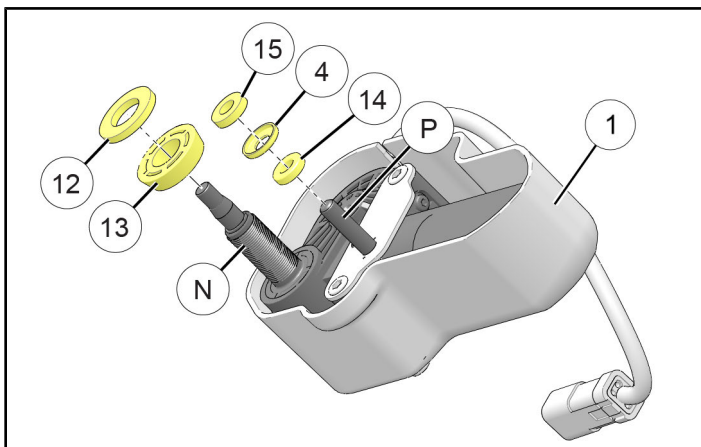

c. Clean mating surfaces of windshield as needed.

Insert wiper motor shaft (N) and anti-rotation stud (P) through corresponding holes in attach plate and plastic trim, then secure as follows:

- **Wiper motor shaft (N)**: rubber washer (12), large cupped plastic washer (11), and nut (10). Ensure rubber washer (12) nests inside cupped washer (11) as shown.
- **Anti-rotation stud (P)**: flat plastic washer (15), small cupped plastic washer (4), and nut (5). Ensure flat washer (15) nests inside cupped washer (4) as shown.

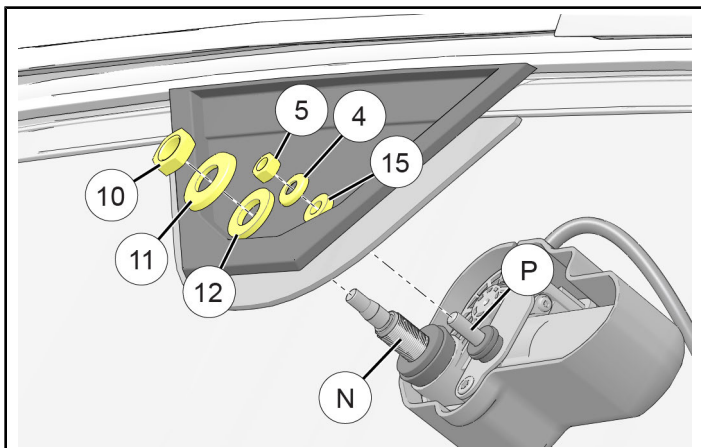

d. Torque nuts to specification.

TORQUE

Wiper motor nut (10): 27-35 in. lbs. (3-4 Nm)
Anti-rotation nut (5): 62-70 in. lbs. (7-8 Nm)

NOTE

Torque on wiper motor nut torque is lower than anti-rotation nut.

e. Push cap (6) onto anti-rotation nut (5).

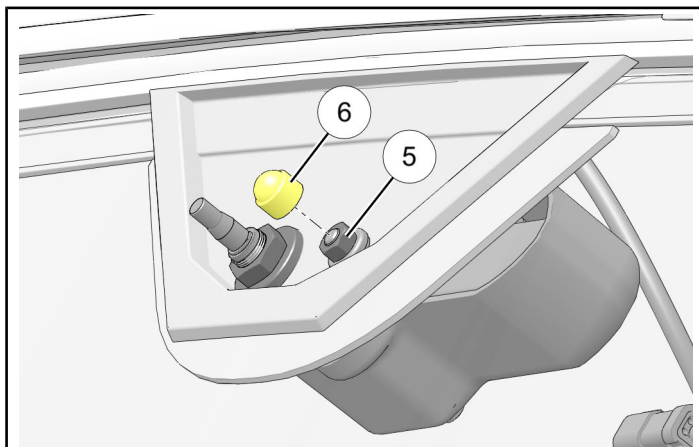

f. Thread cap (9) onto wiper motor shaft (N).
Finger-tighten only.

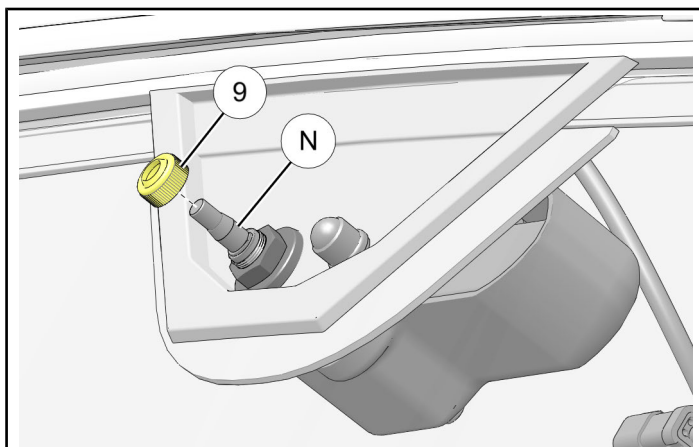

- g. Install wiper blade ② to wiper arm ③ until spring tab on blade locks into slot on arm.

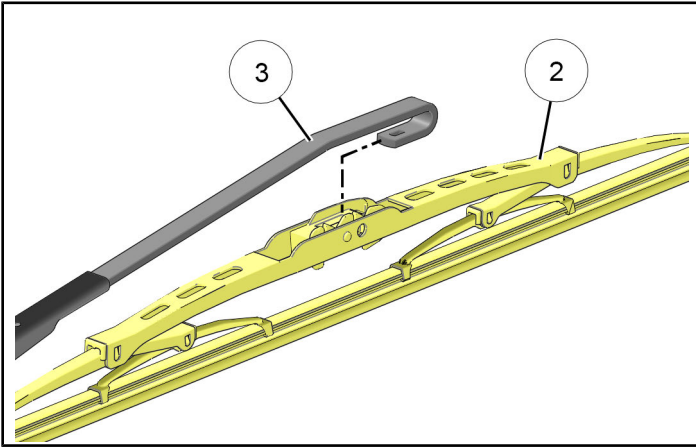

- h. Lift arm cover ⑩. Orient wiper blade/arm assembly parallel to top of windshield, then install to wiper motor shaft ①. Install washer ⑧ and nut ⑦.

Ensure wiper blade/arm assembly is still parallel to top of windshield, then torque nut to specification.

TORQUE

Blade/arm nut ⑦: 15–16 ft. lbs. (20–22 Nm)

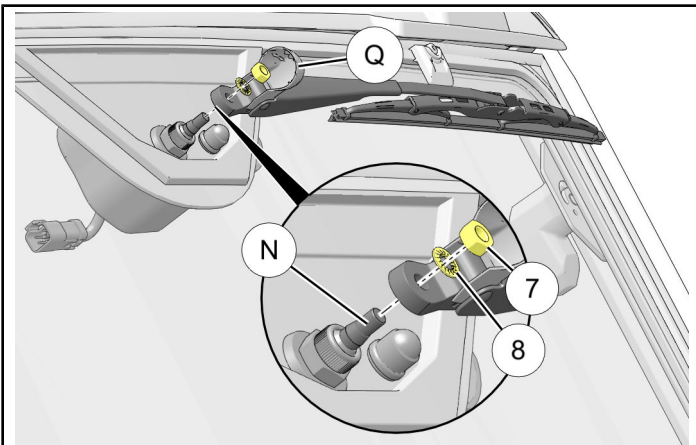

7. Install power harness.

NOTE

See previous section, **HARNES DETAIL**, for connector identification.

- a. Route switch connector 18E and all four bullet connectors 18G-18K on harness ⑱ from under-hood compartment rearward through accessory firewall grommet ⑒ into upper dash compartment.

NOTE

Intake ducting shown transparent for clarity. Grommet may be temporarily removed to facilitate harness passage.

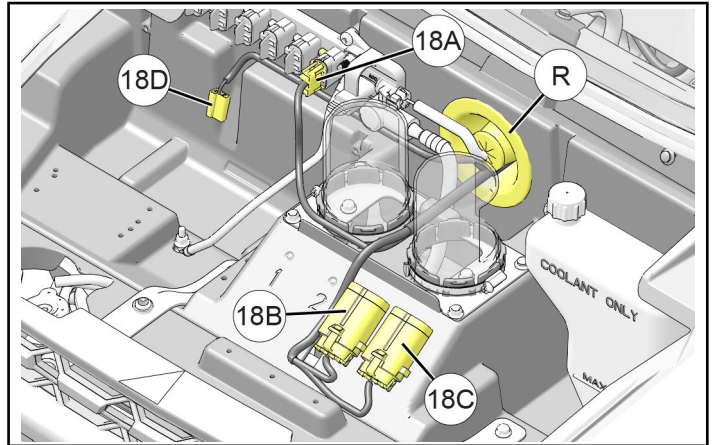

- b. Drill out two accessory plugs (1/4 inch / 6 mm) on under-hood liner, just forward of air intake ducts, then install relay blocks 18B and 18C using attached fir tree clips.

IMPORTANT

Control drill depth to prevent damage to underlying structure, components, wiring, lines, ducts, etc.

- c. Open power cap on vehicle terminal block at any open location, then plug in connector 18A.

NOTE

Remaining connections will be made in later steps.

8. Install switch.

- a. Remove two push pin rivets ⑓ from lower face of control panel. Retain rivets.

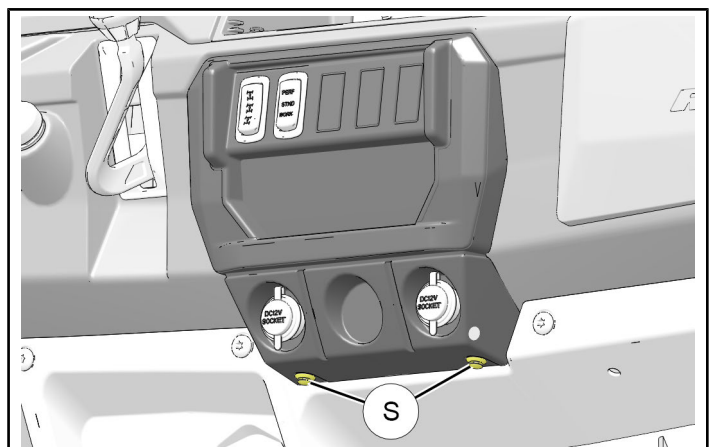

- b. Rotate bottom of control panel rearward, disengaging two side tabs **T**, then drop two upper tabs **U** out of slots in main dash panel.

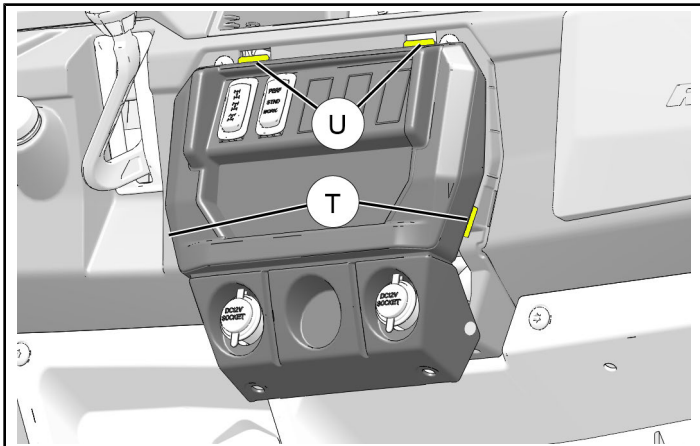

- c. Label and disconnect electrical harnesses from switches, sockets, or other devices from control panel.
- d. Carefully cut one rectangular switch opening **V**. Debur edges.

NOTE

Any open location may be used.

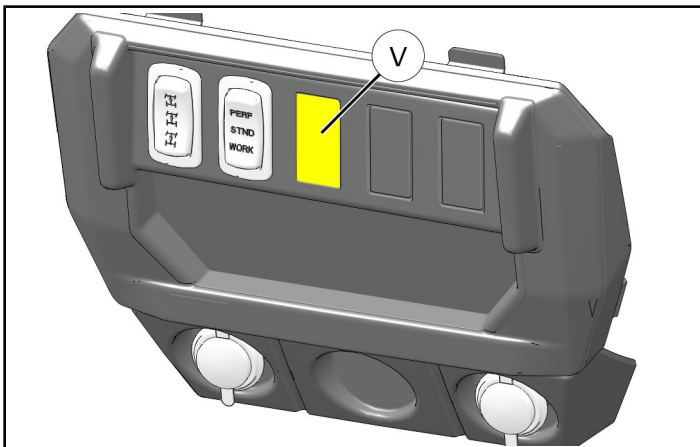

- e. Install switch **19** in control panel opening.
- f. Reaching through cupholder cutout, join connector **18D** on power harness **18** to switch **19**.
- g. Reconnect electrical harnesses disconnected in Step c. above, then reinstall control panel using two retained rivets **5**.

9. Install washer bottle assembly, hose, and nozzle.

- a. Connect washer bottle hose **20** to outlet fitting on washer bottle pump.

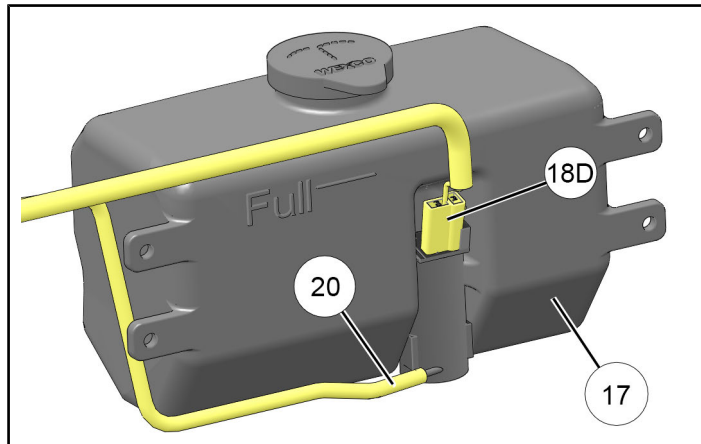

- b. Join connector **18D** on power harness **18** to mating connector on washer bottle pump.
- c. Install washer bottle assembly **17** to underhood liner using four screws **16**. Do not overtighten screws. Ensure washer bottle hose **20** is not pinched.

Notice location of edge clip **21**, but do not install at this time.

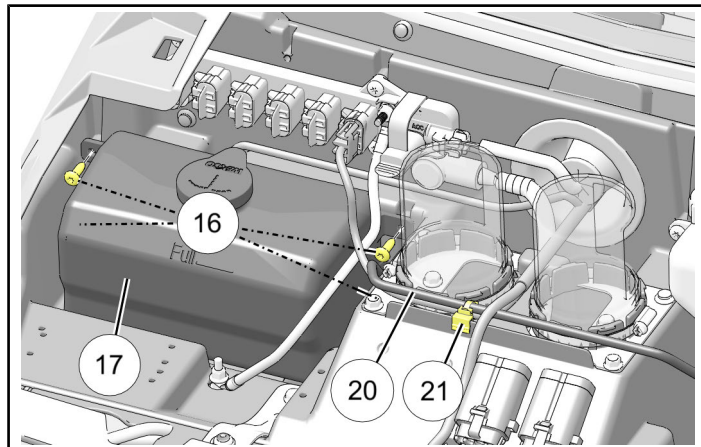

- d. Drill 5/16 inch (8 mm) hole down through fender at location shown for nozzle ⑳.

IMPORTANT

Control drill depth to prevent damage to underlying structure, components, wiring, lines, ducts, etc.

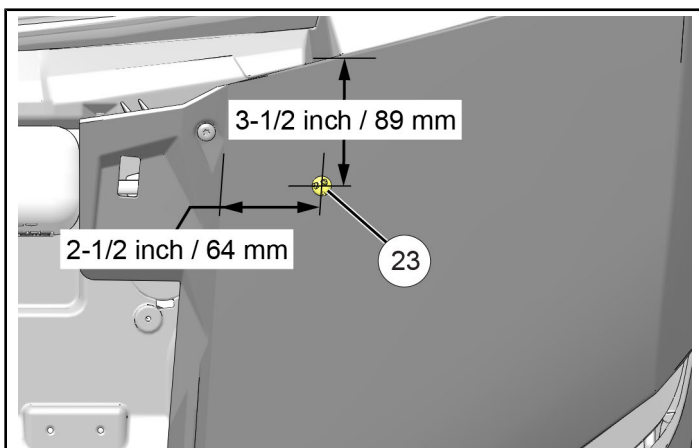

- e. Disassemble nozzle ⑳, then loosely install to fender.

NOTE

Nozzle spray pattern will be adjusted later.

- f. Route washer bottle hose ㉔ towards LH side of vehicle, then connect to nozzle ⑳.

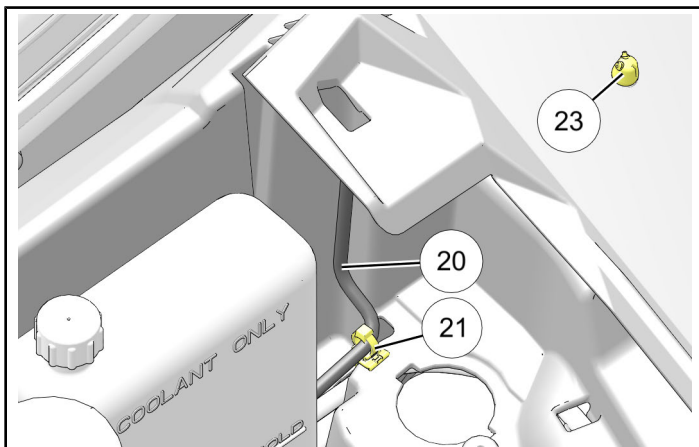

- g. Secure washer bottle hose ㉔ and power harness ⑱ to underhood liner using two edge clips ㉑. See previous Steps c. and f. for location of edge clips.

10. Install ROPS harness.

- a. Join connector on motor assembly ① to connector 22F on ROPS harness ㉒.

Route opposite end of harness (bullet connectors 22A-22D) through oval hole at top of driver side A-pillar, down ROPS, out of welded coupler at base of pillar, and into underhood compartment.

Observe location of two edge clips ㉑, but do not install clips at this time.

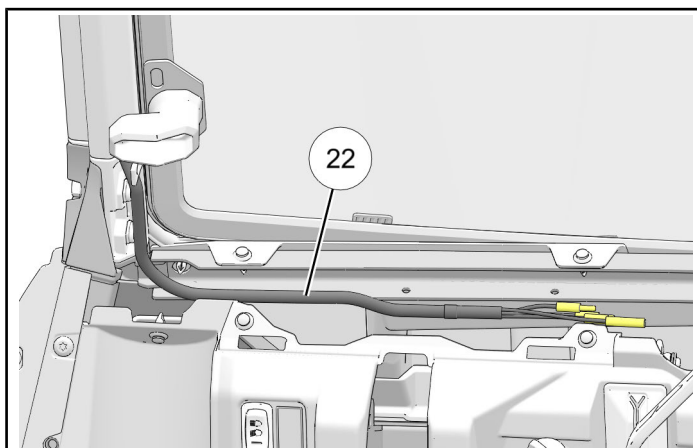
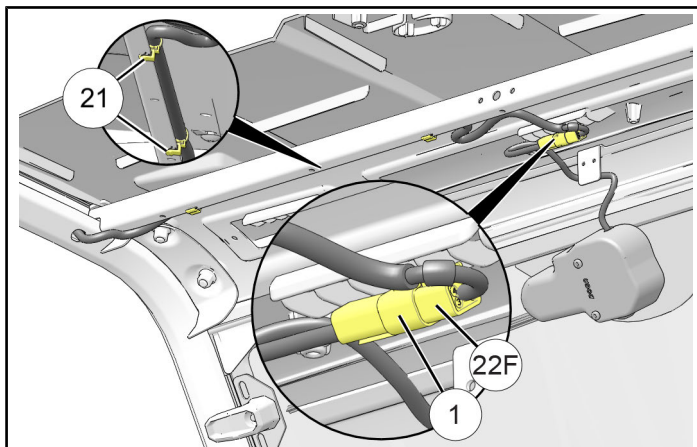

- b. **MATCHING WIRE COLORS**, join bullet connectors 22A–22D on ROPS harness ⑫ to mating bullet connectors 18G–18K on power harness ⑱.

NOTE

Upper dash panel hidden for clarity.

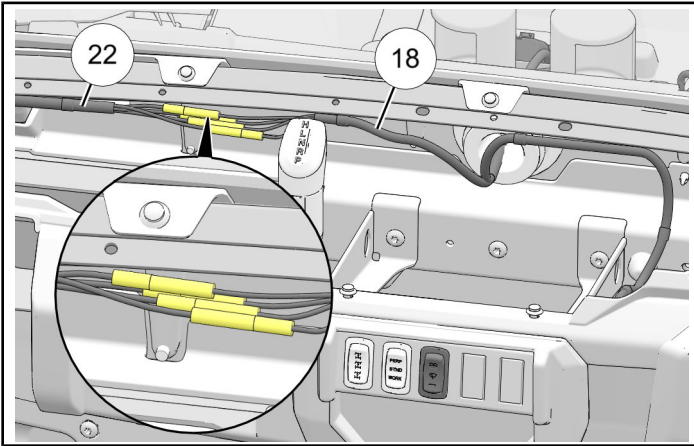

- c. Secure ROPS harness ⑫ and power harness ⑱ to dash support structure using five edge clips ⑳ to prevent contact with sharp edges or moving parts. Clip locations are identified by white tape.

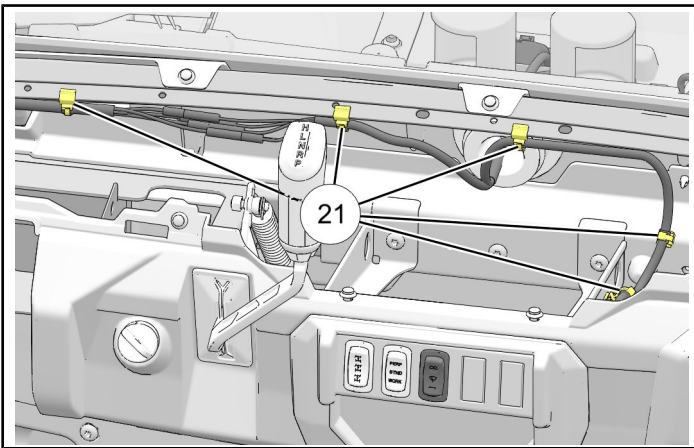

- d. Secure ROPS harness ⑫ to ROPS visor using two edge clips ⑳ to prevent contact with sharp edges or moving parts. See previous Step a.

- 11. Carefully examine all harness routing. Ensure harnesses are routed and secured every 12 inches (300 mm) to prevent contact with hot components, sharp edges, or moving parts (including steering and shift lever components throughout their full range of travel). Use cable ties ㉕ as required.
- 12. Restore access. See Steps 3–5.
- 13. Reconnect black negative (-) cable to battery, then reinstall under-seat storage compartment.

- 14. Fill washer bottle with fluid, turn ignition to "ON", and test system.

- a. Ensure no fluid leakage where washer hose ㉔ connects to pump fitting ⑰ and nozzle ㉚. Correct as required.
- b. Ensure adequate spray coverage on windshield. If not, rotate nozzle on fender and/or adjust nozzle spray angles. Tighten nozzle nut, but do not overtighten.

NOTE

Each nozzle is mounted in a ball socket and is independently adjustable using a fingernail (or equivalent).

TORQUE

Nozzle nut ㉚: 5.3–7.0 in. lbs. (0.6–0.8 Nm)

- 15. **OPTIONAL:** If Visor Audio Kit (PN 2882888, 2882891, or equivalent) is installed, and you also wish to install Rear View Mirror Kit (PN 2879969 or equivalent), then perform the following:

- a. Install mirror assembly to bracket ㉔ using two each screws ㉞ and nuts ㉟ provided with Rear View Mirror Kit.

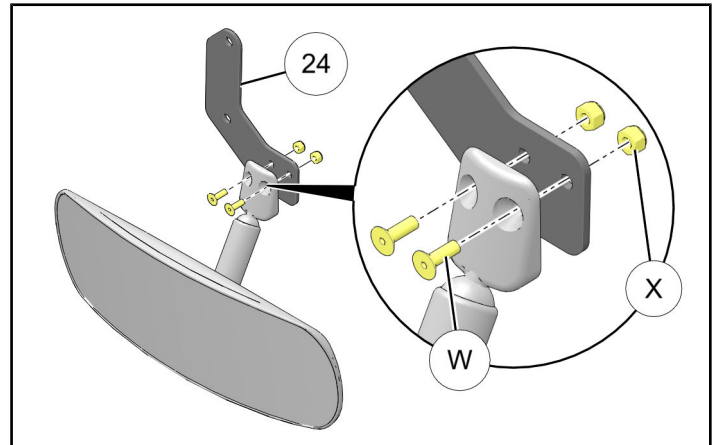

- b. Remove two screws ① from cover on motor assembly ①. Cover can remain in place. Screws will not be reused.

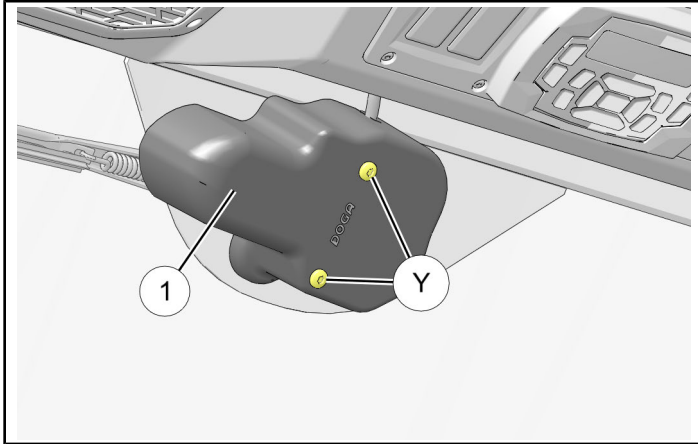

- c. Install bracket ②④ (with attached mirror assembly) to motor assembly ① using two #14 X 3/4 High/Low screws ①⑥.

NOTE

#8 X 3/4 High/Low screws provided with Rear View Mirror Kit will not be used.

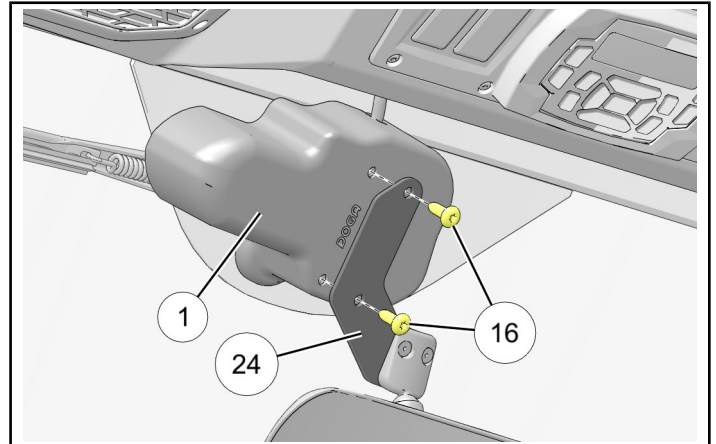

FEEDBACK FORM

A feedback form has been created for the installer to provide any comments, questions or concerns about the installation instructions. The form is viewable on mobile devices by scanning the QR code or by clicking [HERE](#) if viewing on a PC.

