

FRONT BUMPER KIT



P/N 2883746-XXX

APPLICATION

Verify accessory fitment at [Polaris.com](https://www.polaris.com).

BEFORE YOU BEGIN

Read these instructions and check to be sure all parts and tools are accounted for. Please retain these installation instructions for future reference and parts ordering information.

KIT CONTENTS

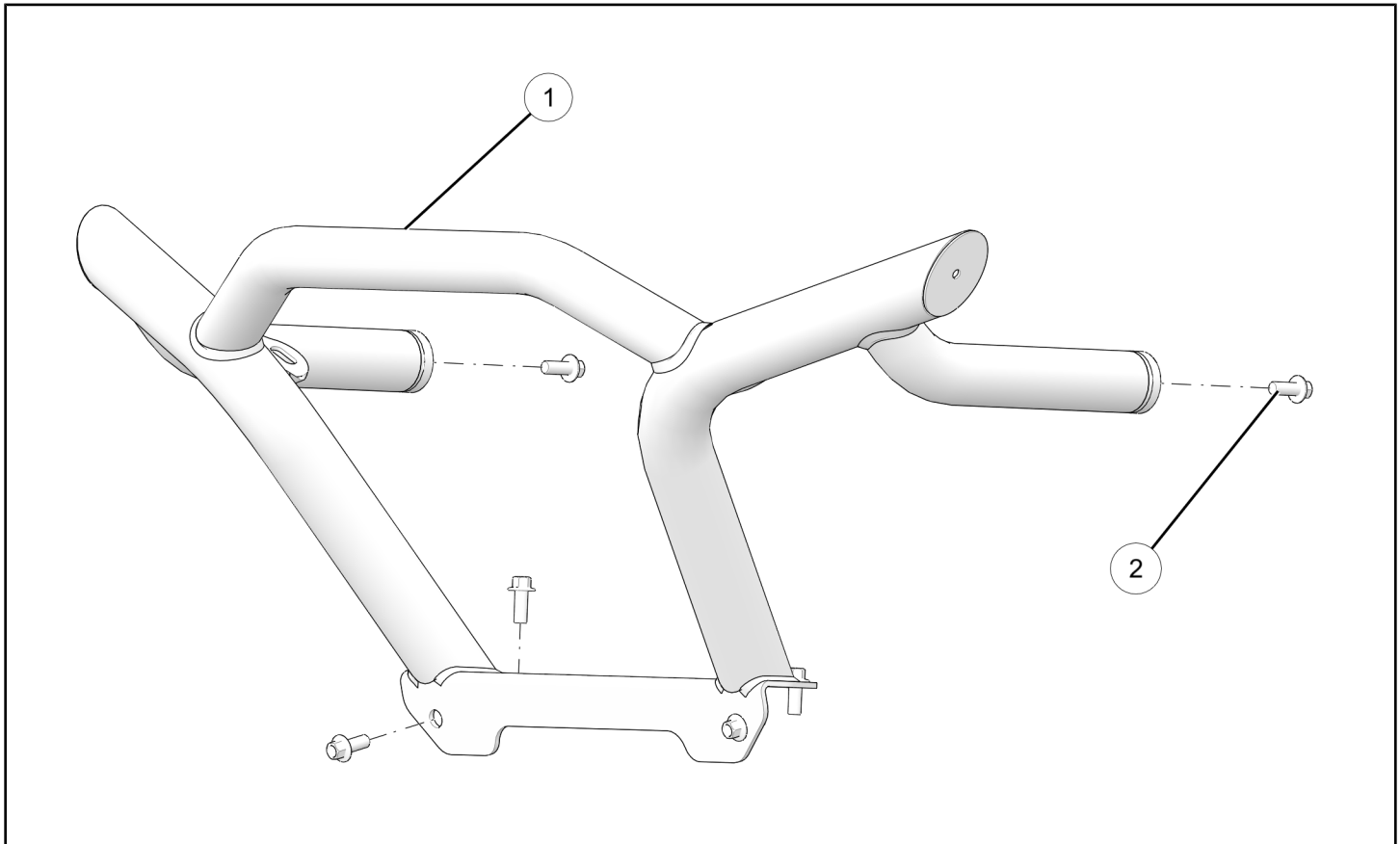

NOTE

XXX = RZR® color code (For example: 458 = Black)

REF	QTY	PART DESCRIPTION	P/N AVAILABLE SEPARATELY	AVAILABLE HARDWARE KIT
1	1	Weld, Bumper, Front, Basic	1024531-XXX	N/A
2	6	Screw, Hex Flange, M8 X 1.25 X 20	7517838	2207775
	1	Instructions	9929127	-

TOOLS REQUIRED

- Safety Glasses
- Socket Set, Metric
- Torque Wrench

IMPORTANT

Your Front Bumper Kit is exclusively designed for your vehicle. Please read the installation instructions thoroughly before beginning. Installation is easier if the vehicle is clean and free of debris. For your safety, and to ensure a satisfactory installation, perform all installation steps correctly in the sequence shown.

INSTALLATION INSTRUCTIONS

VEHICLE PREPARATION

GENERAL

1. Shift vehicle transmission into PARK. Turn ignition switch to OFF position and remove key.

GRILLE REMOVAL

1. Pull down on two tabs, located on top-edge of grille.

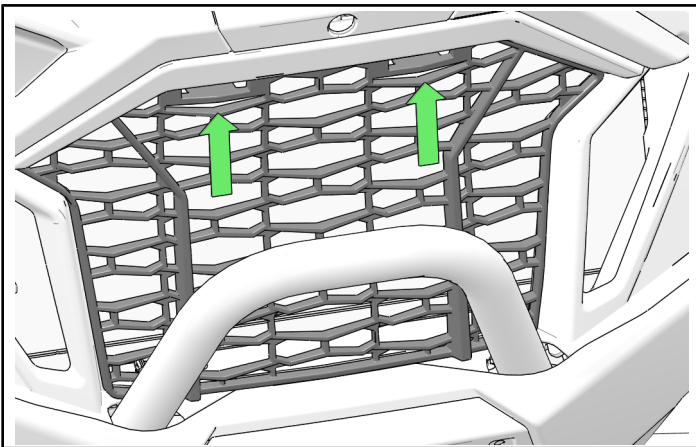

2. Tip grille forward and pull out until bottom tabs are clear of front fascia and bull bumper.

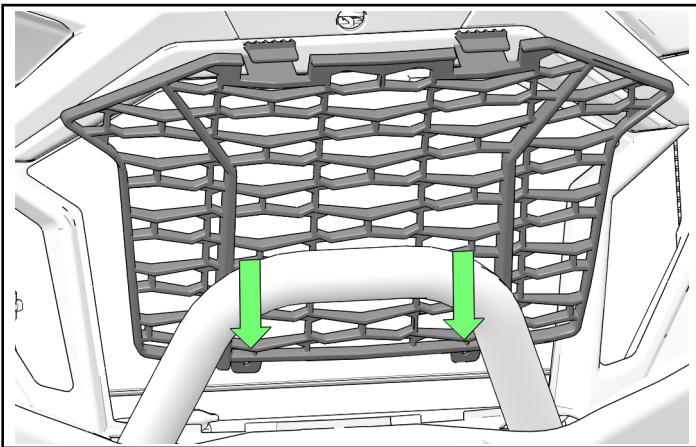

BUMPER FASCIA REMOVAL

1. Remove and retain one screw (A) and one screw (B) from each side of bumper fascia.

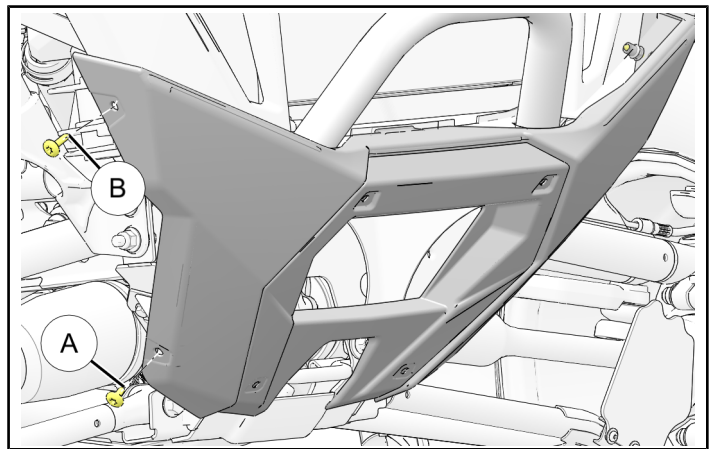

BULL BUMPER REMOVAL

TIP

Front fascia is flexible and can be moved to access mounting hardware.

1. Remove and retain two push-pin rivets (A), holding front fascia to bull bumper.

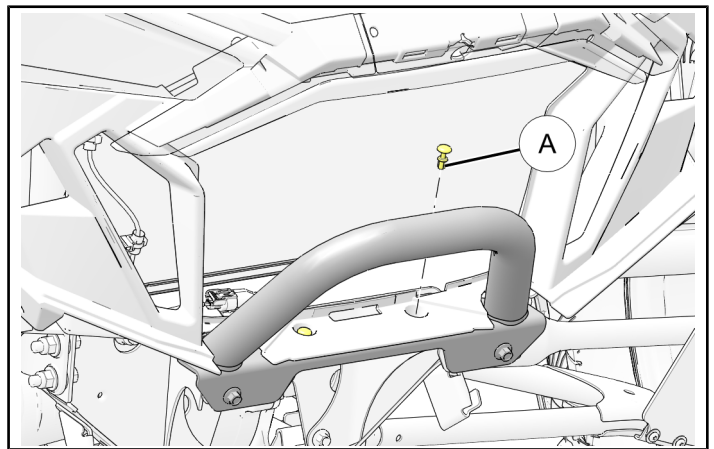

- Remove and discard four screws **B** and retain four nuts **C** connecting bull bumper to bumper brackets.

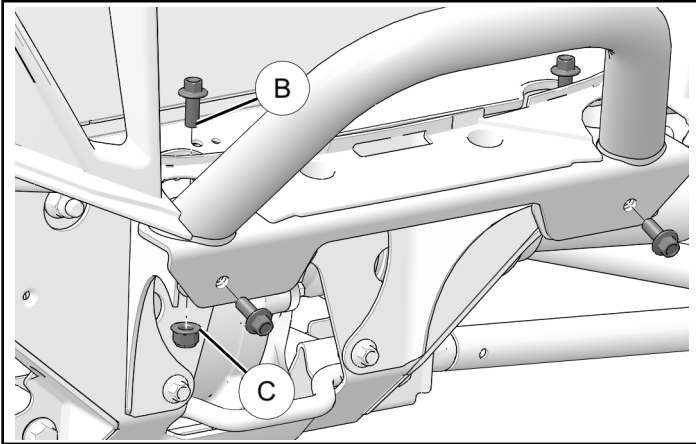

ACCESSORY INSTALLATION

- Align arms of bumper **1** into front fascia openings, below headlights.

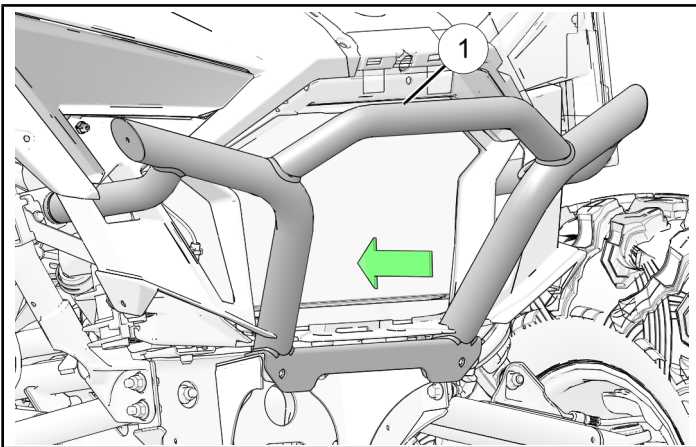

- Install bumper **1** onto two bumper brackets with four bolts **2** and four retained nuts **A**. Counterhold nuts **A** while torquing bolts **2**.

NOTE

Nuts **A** for front-facing bolts **2** are located behind bumper **1**.

TORQUE

Four bolts **2**: **16 ft. lbs. (22 Nm)**

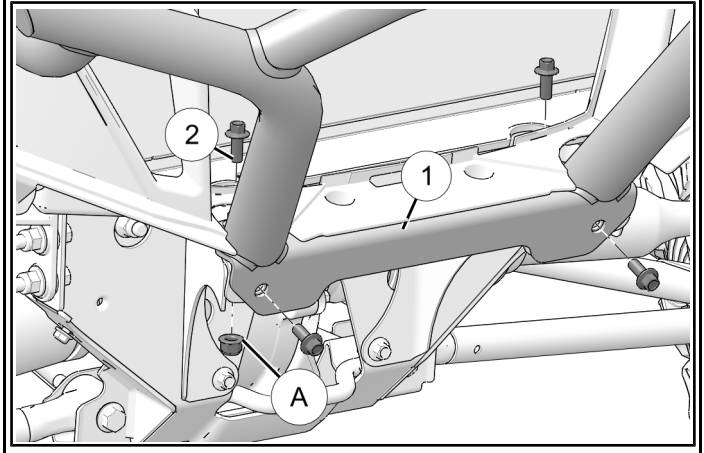

- Install each arm of bumper **1** with one bolt **2**.

TORQUE

Two bolts **2**: **16 ft. lbs. (22 Nm)**

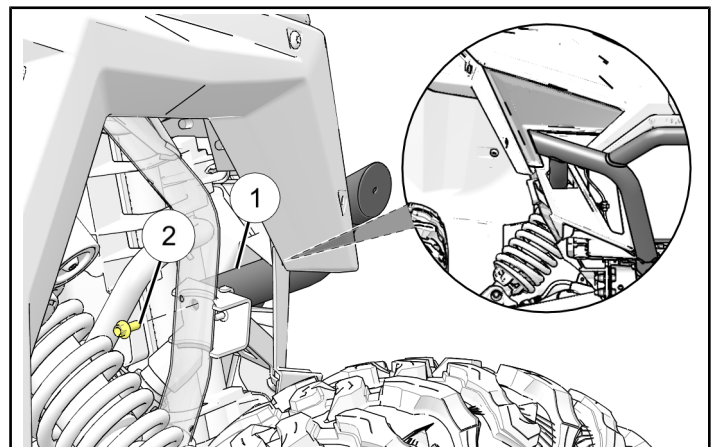

VEHICLE REASSEMBLY

SECURING FRONT FASCIA

1. Secure front fascia to bumper ① with two retained push pin rivets ②.

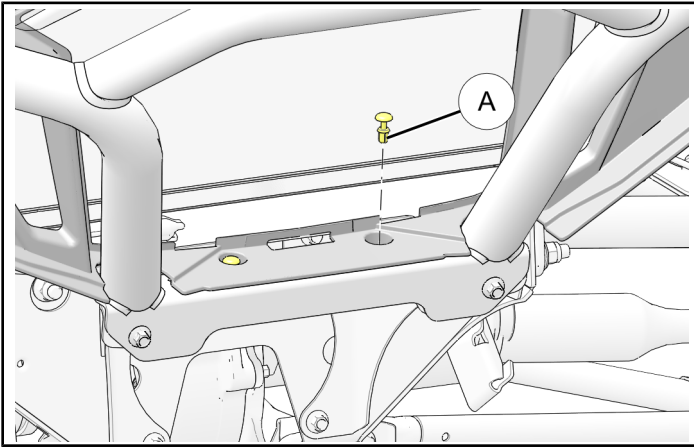

BUMPER FASCIA REINSTALLATION

1. Reinstall bumper fascia with two screws ① and two screws ②.

TORQUE

Two screws ①: **97 in. lbs. (11 Nm)**
Two screws ②: **97 in. lbs. (11 Nm)**

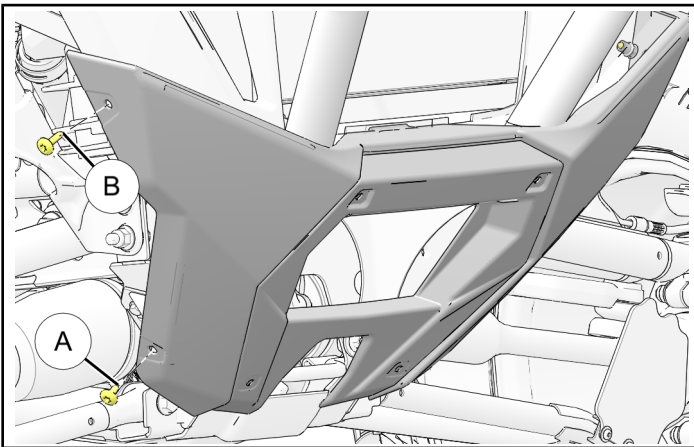

FEEDBACK FORM

A feedback form has been created for the installer to provide any comments, questions or concerns about the installation instructions. The form is viewable on mobile devices by scanning the QR code or by clicking [HERE](#) if viewing on a PC.

GRILLE INSTALLATION

1. Tip bottom grille tabs into front fascia.

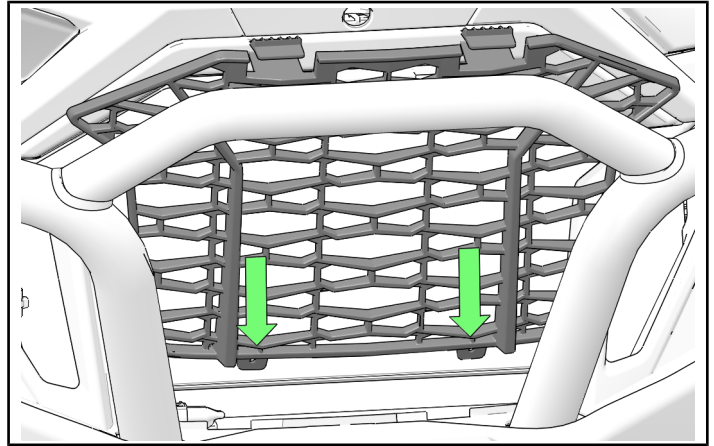

2. Push top of grille into front fascia until grille snaps into place.

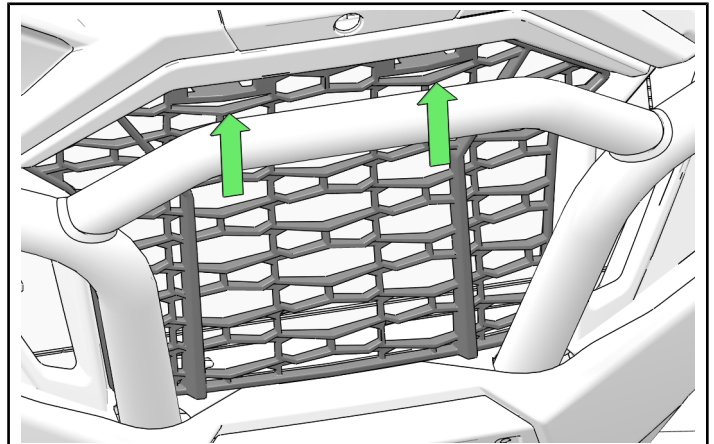

FEEDBACK FORM

