

FRONT BUMPER KIT



P/N 2879449, 2881583

APPLICATION

Verify accessory fitment at Polaris.com.

BEFORE YOU BEGIN

Read these instructions and check to be sure all parts and tools are accounted for. Please retain these installation instructions for future reference and parts ordering information.

KIT CONTENTS

This Kit includes:

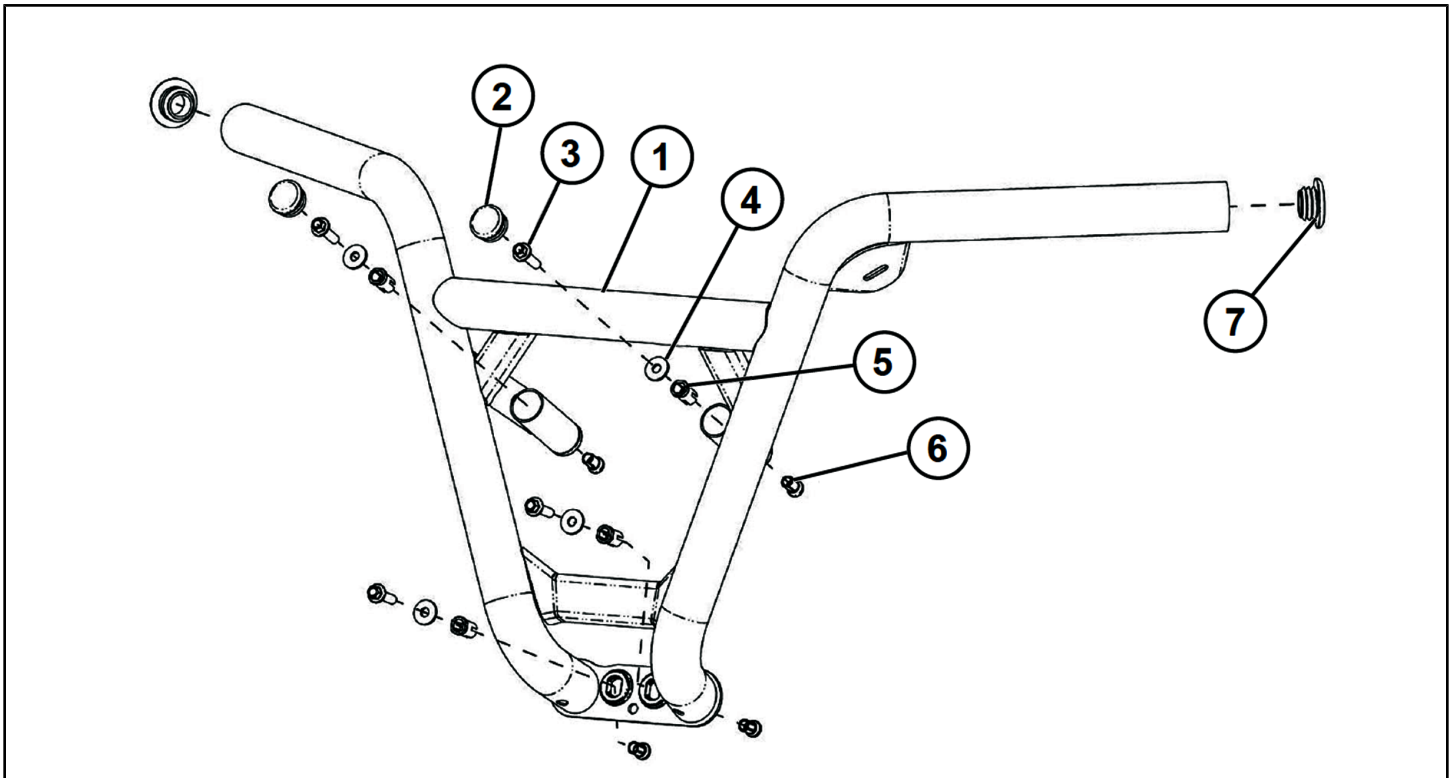

REF	QTY	PART DESCRIPTION	PART NUMBER
1	1	Bumper, Front	-
2*	2	Plug, 1.25	5450305
3*	4	Screw, Hex Flange - M8 X 1.25 X 30	7520234
4*	4	Washer - 0.327 X 0.875 X 0.090	7556341
5*	4	Expansion Tube, Anchor	5337853
6*	4	Wedge, Anchor	5632958
7*	2	Plug, 1.75	5434191
	1	Instructions	9924458

Items marked (*) are included in Hardware Kit PN 2205113.

TOOLS REQUIRED

- Safety Glasses
- Hammer
- Pin Punch

- Pliers, Arc Joint
- Socket Set, Metric
- Torque Wrench

IMPORTANT

Your FRONT BUMPER KIT is exclusively designed for your vehicle. Please read the installation instructions thoroughly before beginning. Installation is easier if the vehicle is clean and free of debris. For your safety, and to ensure a satisfactory installation, perform all installation steps correctly in the sequence shown.

ASSEMBLY TIME

Approximately 30 minutes

INSTALLATION INSTRUCTIONS

1. Shift vehicle transmission into "PARK". Turn key to "OFF" position and remove from vehicle.
2. Guide front bumper ① into position so all four expansion anchor assemblies ③ ④ ⑤ ⑥ fully engage vehicle frame mounting holes as shown.
4. While ensuring bumper ① is firmly seated against vehicle frame, and anchor flats are properly aligned, tighten four screws ③ as shown. Torque to specification.

IMPORTANT

Bumper must be firmly seated against vehicle frame at all four locations before tightening screws. Anchor assemblies are not intended to draw bumper and frame together.

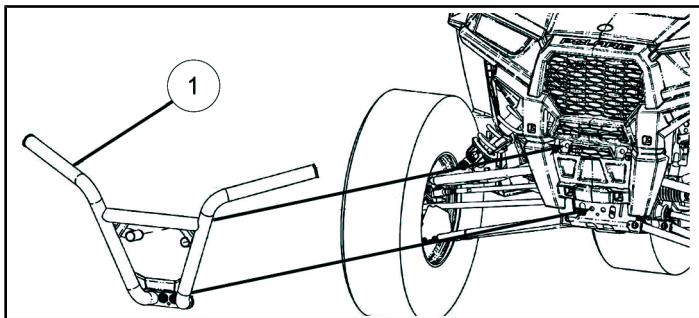

3. Ensure expansion anchors are fully seated by slowly rotating each anchor assembly ③ ④ ⑤ ⑥, verifying that flat faces of tube ⑤ have slipped into and aligned with flat faces of welded socket (A) as shown.

IMPORTANT

Failure to properly align anchor flats will result in incomplete fastener engagement and improper torque application.

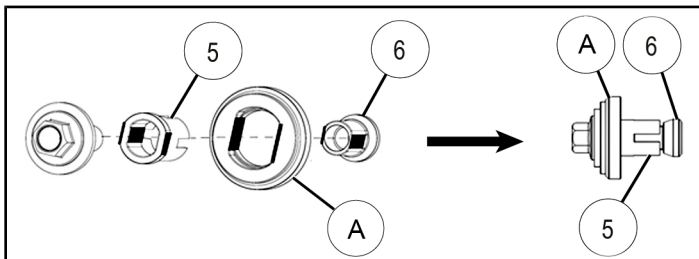

TORQUE

16 ft. lbs. (22 Nm)

NOTE

After anchor begins expanding repositioning may become difficult.

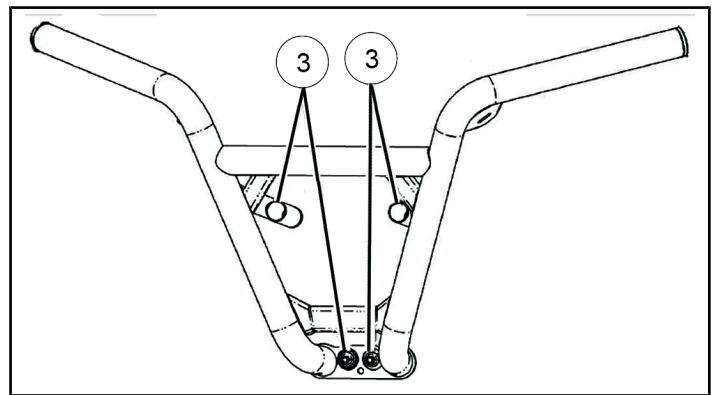

5. Insert two plugs ② into bumper as shown.

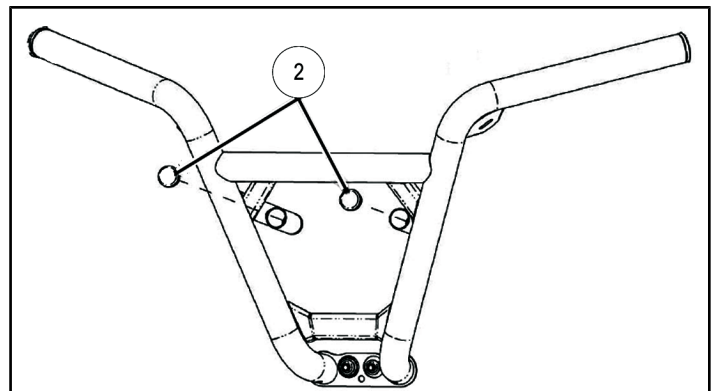

6. Insert two plugs ⑦ into outboard ends of bumper tubing (if not pre-installed from factory).

REMOVAL INSTRUCTIONS

NOTE

Bumper re-installation requires new Hardware Kit PN 2205113 (purchased separately).

1. Remove two plugs ② from upper attach locations as shown.

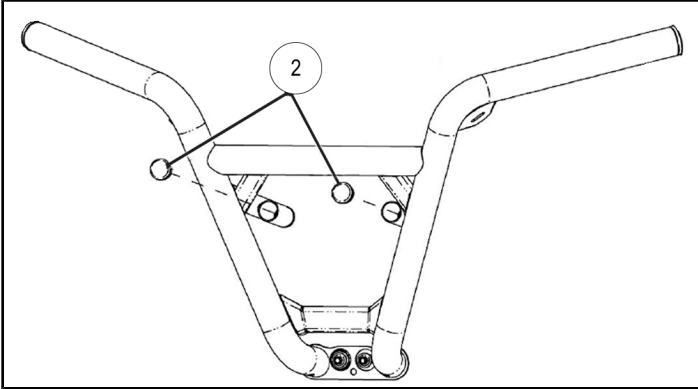

CAUTION

Bumper weighs approximately 11 lbs. (5 Kg). Failure to adequately support bumper during removal may result in personal injury or damage to equipment.

2. Remove four upper and lower screws ③ and washers ④ from bumper attach locations. Remove bumper as shown.

NOTE

Bumper may need to be wobbled back and forth to allow anchor expansion tubes ⑤ to pass through welded sockets ①.

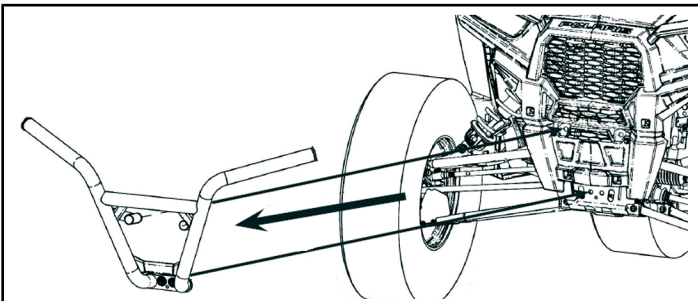

3. Using pin punch, drive wedge ⑥ rearward out of expansion tube ⑤ at each attach point as shown.

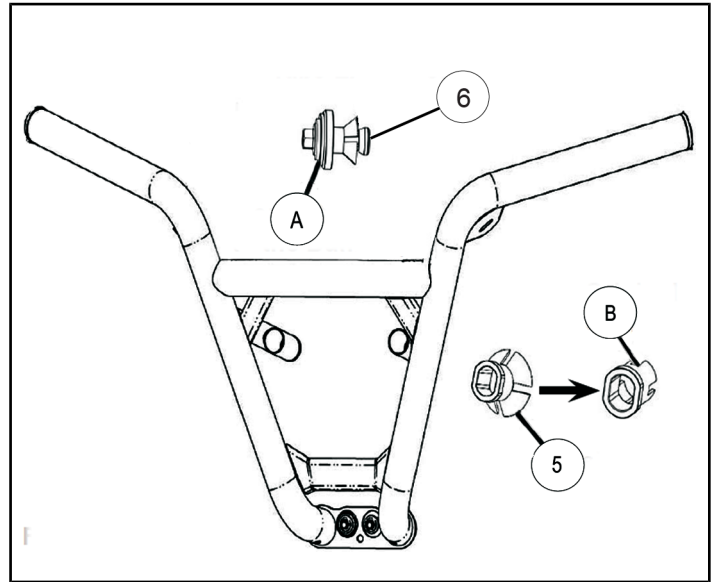

4. Using arc-joint pliers, grasp expansion tube ⑤ and remove from frame at each attach point. During removal tabs will straighten as shown by ⑧ above. Discard old hardware.