

WINCH KIT



P/N 2882708, 2883825

APPLICATION

Verify accessory fitment at Polaris.com.

BEFORE YOU BEGIN

Read these instructions and check to be sure all parts and tools are accounted for. Please retain these installation instructions for future reference and parts ordering information.

KIT CONTENTS

This Kit includes:

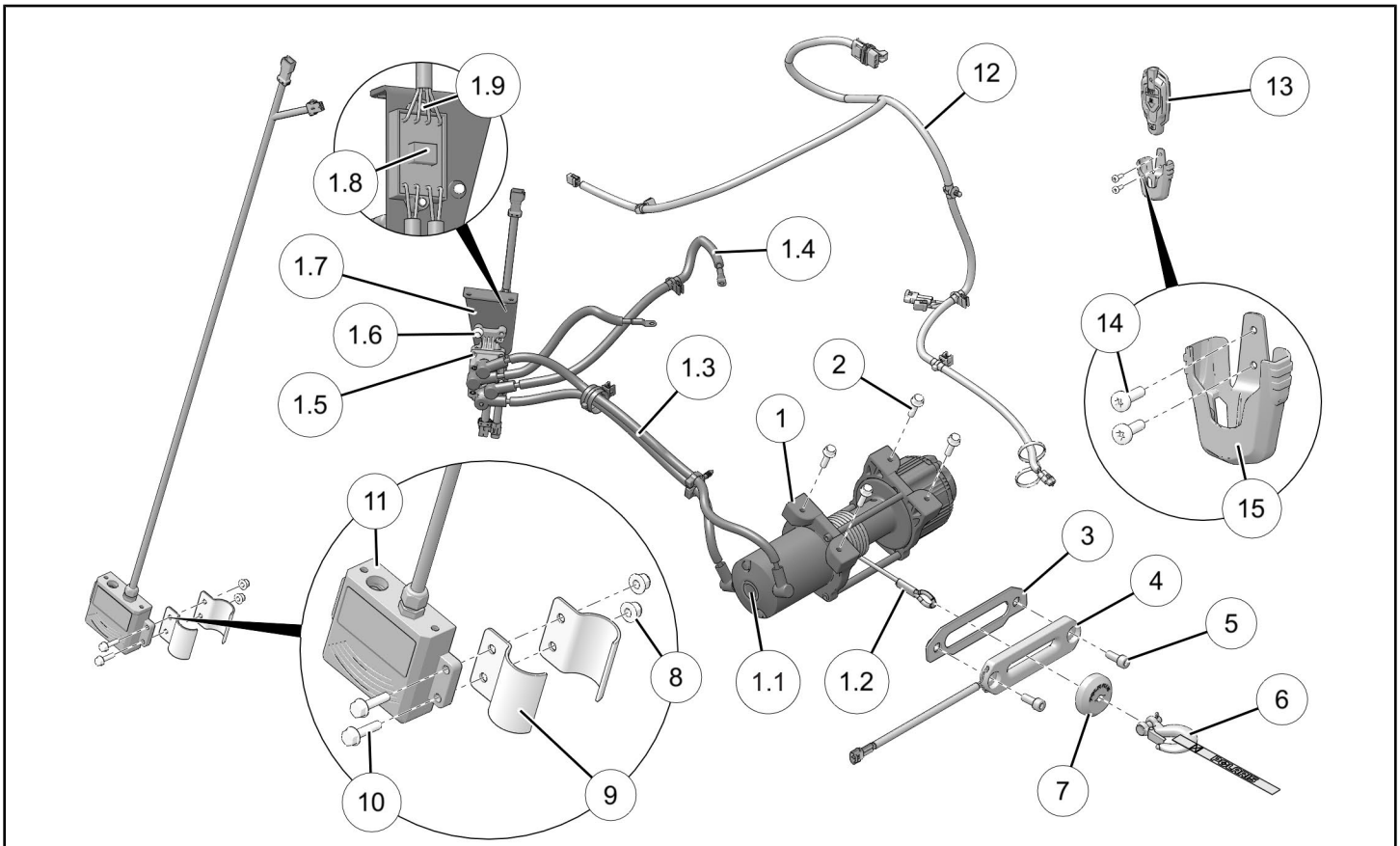

REF	QTY	PART DESCRIPTION	PART NUMBER	INCLUDED IN HARDWARE KIT
1	1	Winch (includes items 1.1–1.9)	-	-
1.1	1	- Winch, Motor Assembly, 4500 lb, Single Speed* (Kit 2882708 only)	2636470	-
	1	- Winch, Motor Assembly, 4500 lb, Rapid Rope Recovery** (Kit 2883825 only)	2206382	-
1.2	1	- Rope	2879187	-
1.3	1	- Cables, Winch-to-Contactor	4017416	-
1.4	1	- Cables, Contactor-to-Battery	4017415	-
1.5	1	- Contactor	4015600	-

REF	QTY	PART DESCRIPTION	PART NUMBER	INCLUDED IN HARDWARE KIT
1.6	2	- Screw, Hex Flange - M6 X 1.0 X 20	7518141	2207448
1.7	1	- Bracket, Contactor and Autostop Controller	5265054	-
1.8	1	- Controller, Autostop	-	2883454
1.9	2	- Screw, Torx® Pan Head, High/Low - #10 X 5/8	7518238	2883454 / 2207448
2	4	Screw, Hex Flange - M8 X 1.25 X 30	7520234	2207448
3	1	Plate, Fairlead Backer	5260831	-
4	1	Fairlead, Autostop	-	2883454
5	2	Screw, Socket Cap - M10 X 1.5 X 25	7517358	2883454 / 2207448
6	1	Hook	2411836	-
7	1	Stop, Magnetic	-	2883454
8	2	Nut, Hex Flange, Locking - M6 X 1.0	7547274	2207448
9	2	Bracket	5264870	-
10	2	Screw, Hex Flange - M6 X 1.0 X 25	7516823	2207448
11	1	Receiver, Wireless	-	2883455
12	1	Harness, Power and Control	2414086	-
13	1	Remote, Wireless	-	2883455
14	2	Screw, Torx® Pan Head, High/Low - #10 X 0.75	7512026	2883455 / 2207448
15	1	Holder, Wireless Remote	-	2883455
	1	Winch User Guide	9923644	-
	1	Instructions	9927976	-

Item marked (*): Replacement Single Speed gear selector knob PN 2205265.

Item marked (**): Replacement Rapid Rope Recovery gear selector knob PN 2207842.

TOOLS REQUIRED

- Safety Glasses
- Drill
- Drill Bit: 1/8 inch (3 mm)
- Pliers, Push Pin Rivet
- Pliers, Slip Joint
- Screwdriver Set, Torx®
- Socket Set, Hex Bit, Metric
- Socket Set, Metric
- Torque Wrench
- Wrench Set, Metric

IMPORTANT

Your Winch Kit is exclusively designed for your vehicle. Please read the installation instructions thoroughly before beginning. Installation is easier if the vehicle is clean and free of debris. For your safety, and to ensure a satisfactory installation, perform all installation steps correctly in the sequence shown.

HARNESS DETAIL

WINCH HARNESS ①

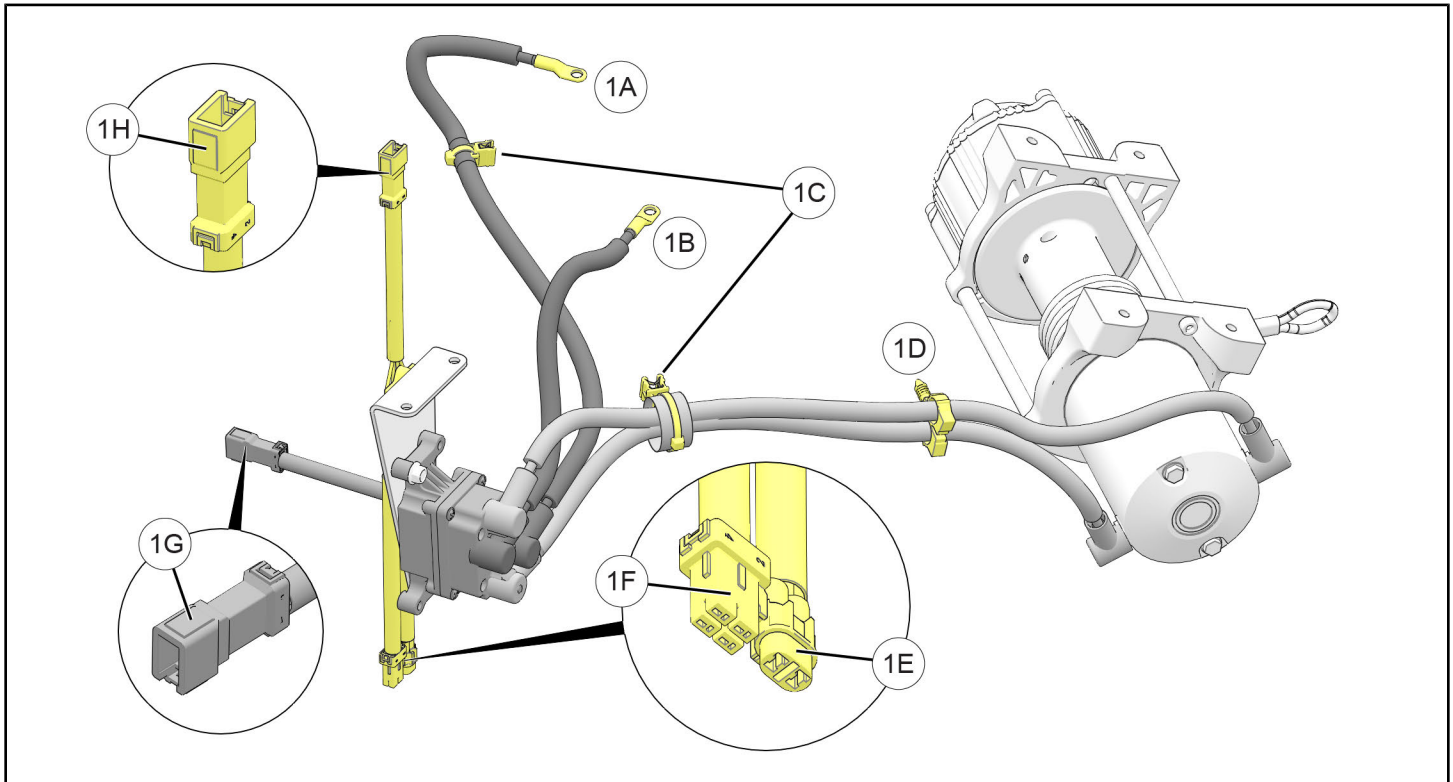

REF	PART DESCRIPTION	WIRE COLOR	PIN QTY/ GENDER	CONNECTS TO
1A	Ring Terminal - 1/4 inch (6 mm)	Black	-	Battery negative (-)
1B	Ring Terminal - 1/4 inch (6 mm)	Red	-	Battery positive (+)
1C	Clip, Edge	-	-	Vehicle structure
1D	Clip, Routing	-	-	Vehicle structure
1E	Connector, Autostop Fairlead	-	2 female	Control harness ⑫, connector 12C
1F	Connector, Winch Controller/Contactor	-	4 female	PRE-CONNECTED to 1G
1G	Connector, Winch Controller/Contactor	-	4 male	PRE-CONNECTED to 1F
1H	Connector, Winch Controller/Contactor	-	4 male	Control harness ⑫, connector 12D

AUTOSTOP FAIRLEAD HARNESS ④

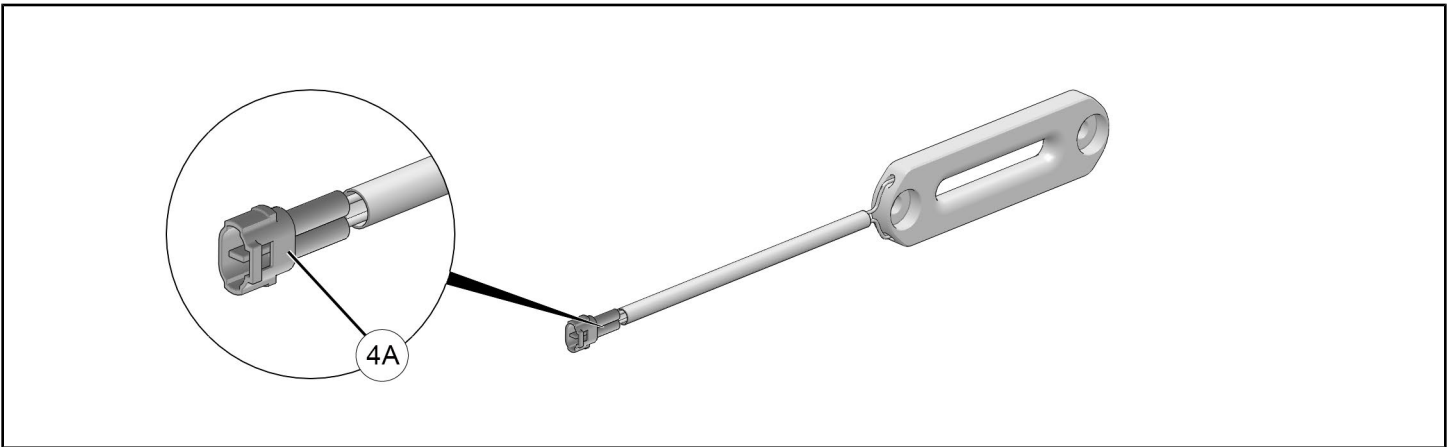

REF	PART DESCRIPTION	WIRE COLOR	PIN QTY/ GENDER	CONNECTS TO
4A	Connector, Autostop Fairlead	-	2 male	Control harness ⑫, connector 12F

WIRELESS RECEIVER HARNESS ⑪

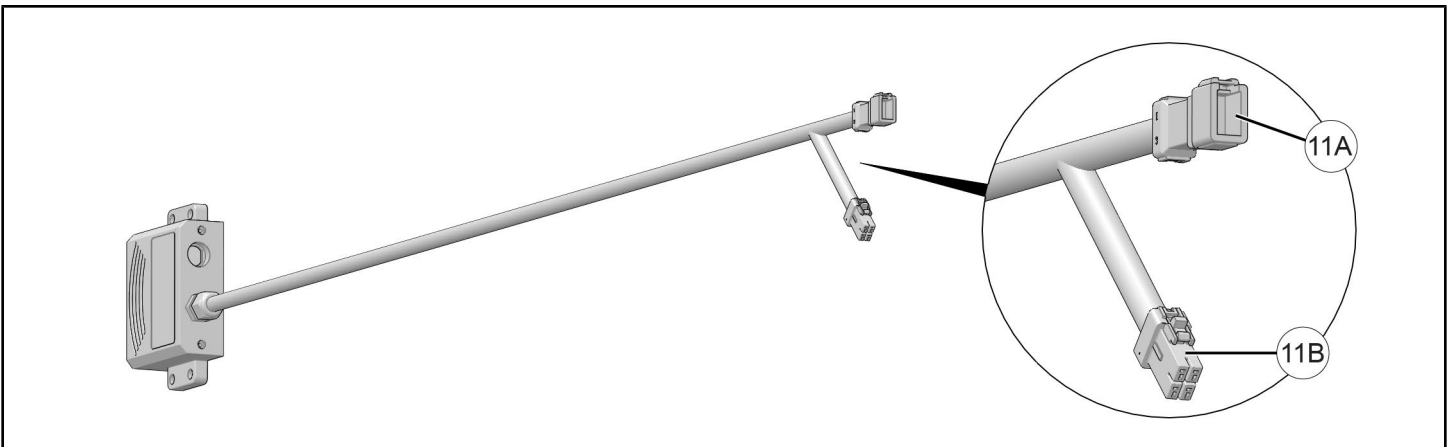

REF	PART DESCRIPTION	WIRE COLOR	PIN QTY/ GENDER	CONNECTS TO
11A	Connector, Winch Controller/Contactor	-	4 male	Control harness ⑫, connector 12H
11B	Connector, Wired Remote	-	4 female	(unused)

* Or compatible kit.

CONTROL HARNESS ⑫

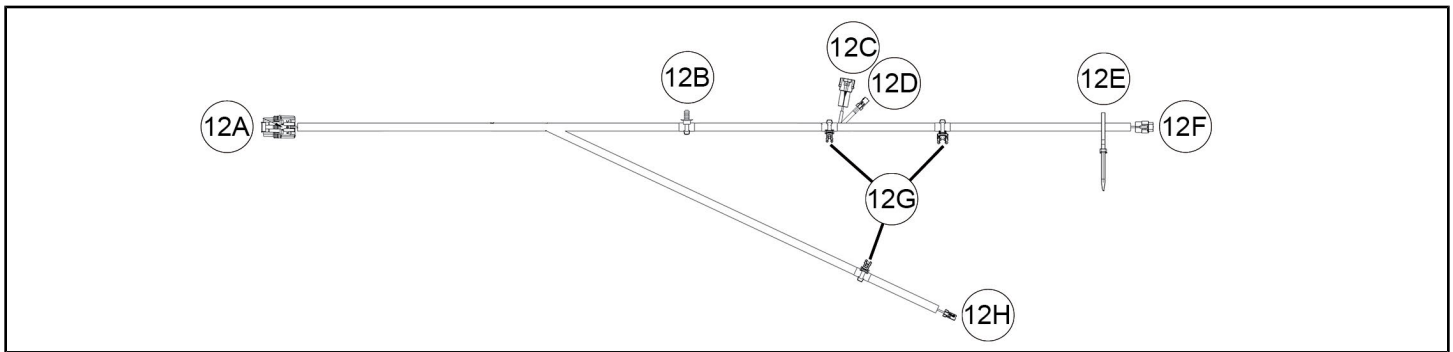

REF	PART DESCRIPTION	WIRE COLOR	PIN QTY/ GENDER	CONNECTS TO
12A	Connector, Terminal Block	-	3 female	Vehicle terminal block
12B	Clip, Routing	-	-	Vehicle structure
12C	Connector, Autostop Controller	-	2 male	Winch harness ①, connector 1E
12D	Connector, Autostop Controller	-	4 female	Winch harness ①, connector 1H
12E	Cable Tie, Double Loop	-	-	Winch-to-contactor cables (mechanical connection only)
12F	Connector, Autostop Fairlead	-	2 female	Autostop fairlead harness ④, connector 4A
12G	Clip, Edge	-	-	Vehicle structure
12H	Connector, Wireless Receiver	-	4 female	Wireless receiver harness ⑪, connector 11A

INSTALLATION INSTRUCTIONS

IMPORTANT

Rapid Rope Recovery Winch Kit 2883825:
Carefully read **GEAR SELECTION** section at end of manual to familiarize yourself with proper operation of Rapid Rope Recovery function.

1. Shift vehicle transmission into "PARK". Turn ignition key to "OFF" position and remove from ignition switch.
2. Remove hood and under-hood storage compartment, then disconnect black negative (-) cable from battery.
3. Gain access.
 - a. Remove windshield (if installed).

- b. Remove visor by removing two screws ①. Retain screws.

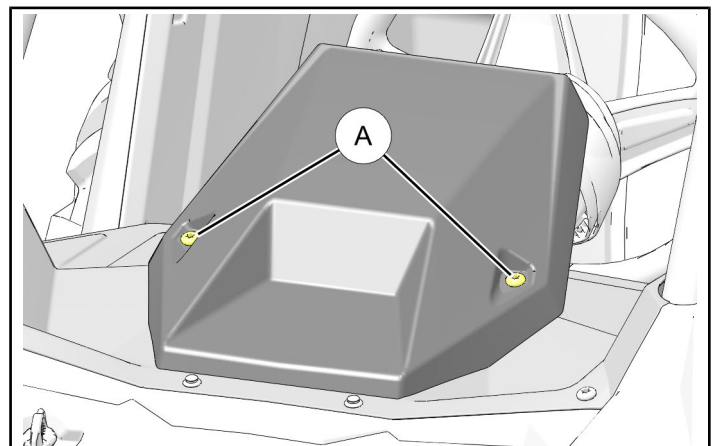

- c. Remove RH A-pillar access cover **(B)** by grasping rear inboard corner of cover with fingers, then lift to detach three locking tabs **(C)**, two posts **(D)**, and two locking tabs **(E)**. Set cover aside.

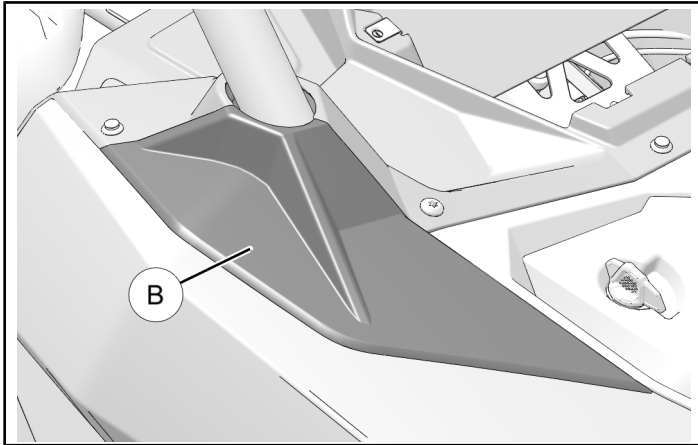

NOTE

View of underside of cover looking rearward.

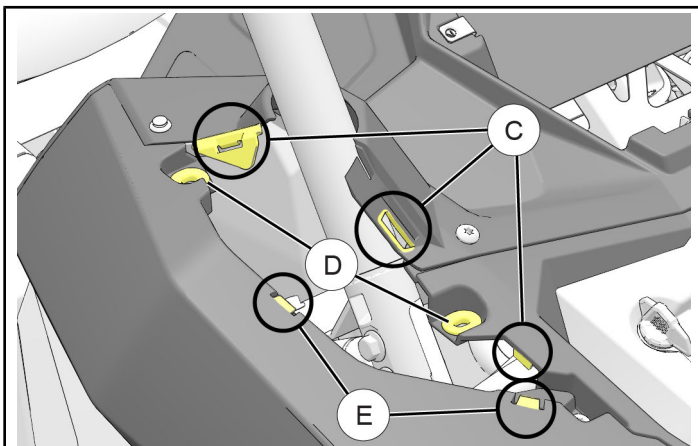
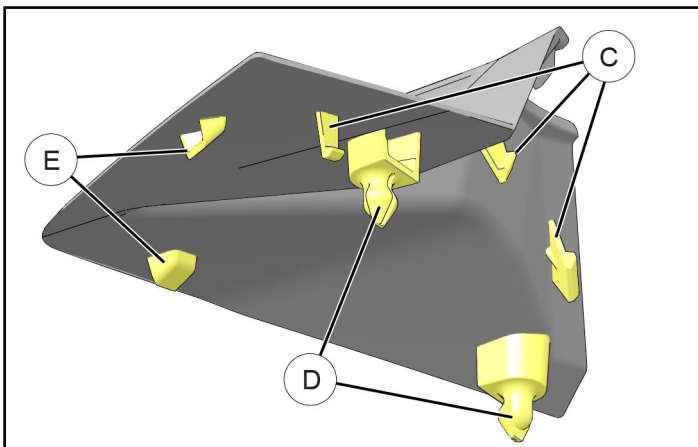

- d. Remove RH rear fender by unlocking quarter turn latch **(F)** and unhooking two straps **(G)**.

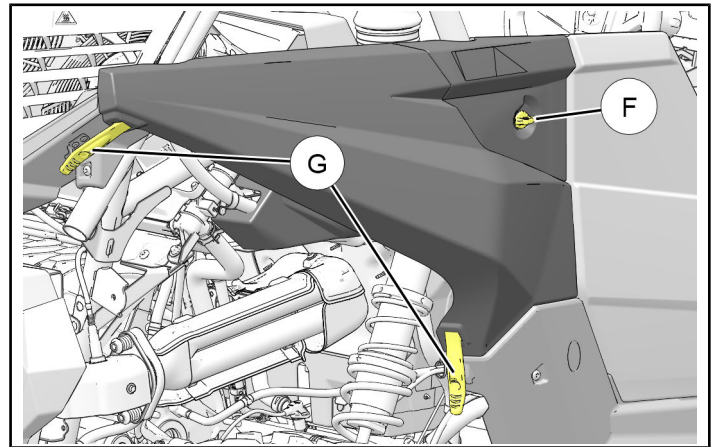

- e. From inside of vehicle remove five screws **(H)** securing RH exterior body panel to frame. Retain screws.

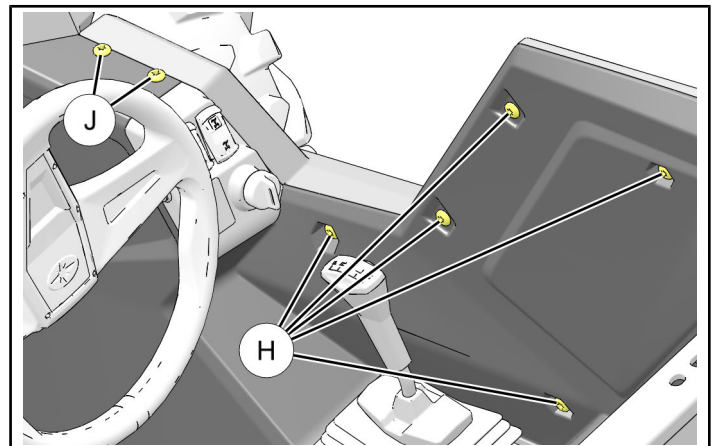

- f. From outside of vehicle, and while supporting exterior body panel, remove final two screws (J), then remove panel by detaching locking tab (K) from mating slot (L) in front fender.

NOTE

View of outer RH door panel, interior side.

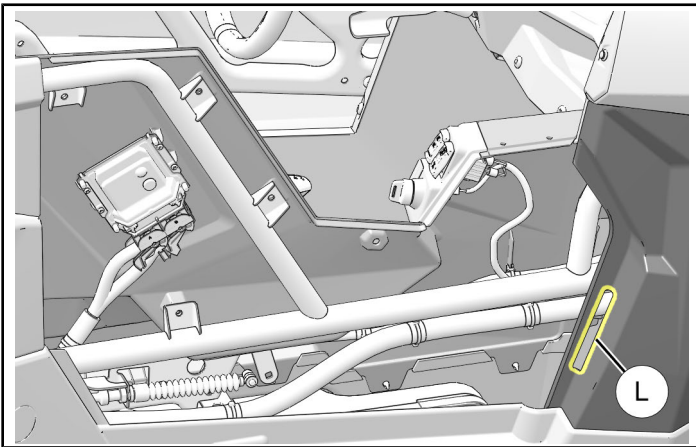
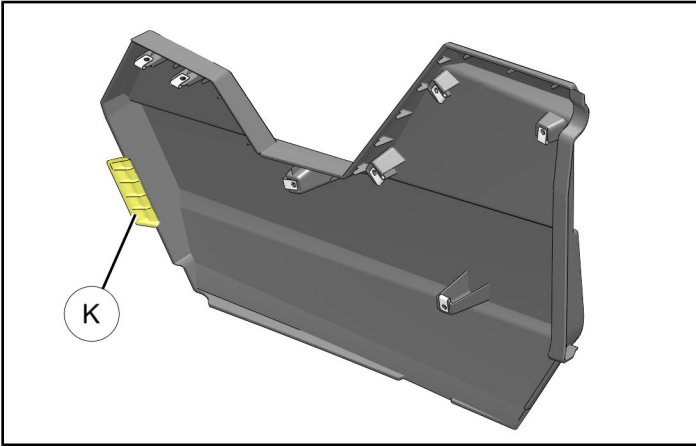

4. If HD Front Bumper (PN 2882693) has NOT yet been installed, then proceed to Step 5. Otherwise, remove bumper as follows:

- a. Remove two screws (M) and tow hook (N) from bottom of bumper. Retain hardware.

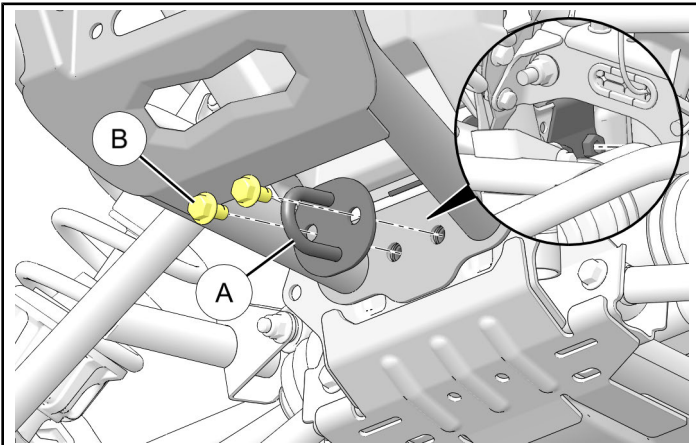

CAUTION

Bumper weighs approximately 17 lbs. (8 kg). Provide adequate support for bumper before removing upper screws. Failure to comply may result in personal injury or damage to bumper.

- b. While supporting bumper, remove upper screw (P). Repeat for opposite side, then remove bumper and set aside. Retain hardware.

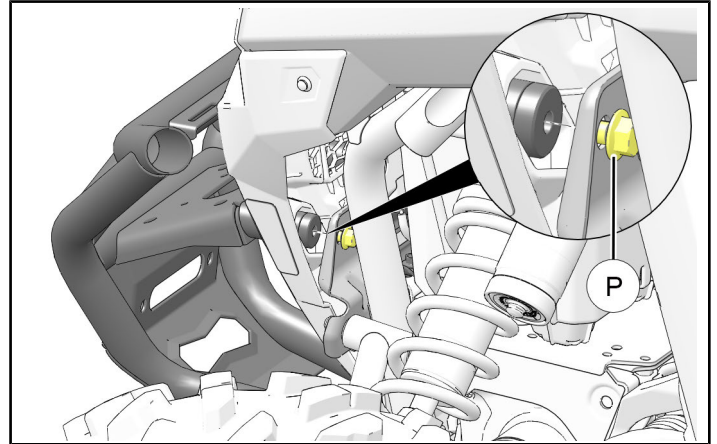

5. Install winch assembly to HD Front Bumper (PN 2882693).

- a. Install autostop fairlead (4) and fairlead backer plate (3) to bumper using two screws (5). Ensure fairlead is oriented so electrical harness exits toward RH side of bumper as shown. Tighten screws.

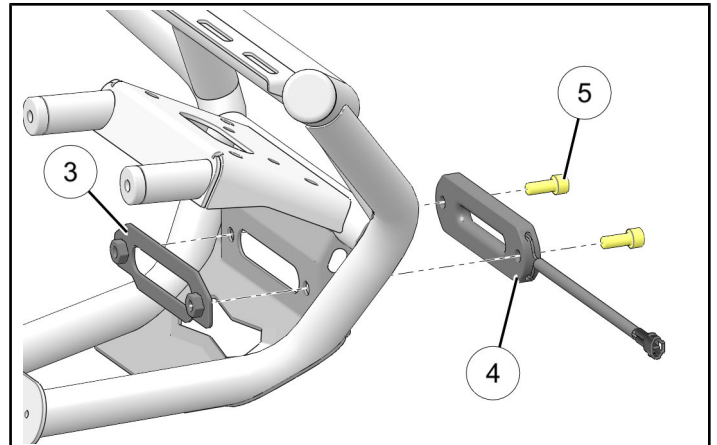

- b. Unwind BY HAND several turns of rope from winch spool. While lifting bumper into position thread loop at end of rope through bumper and fairlead ④.

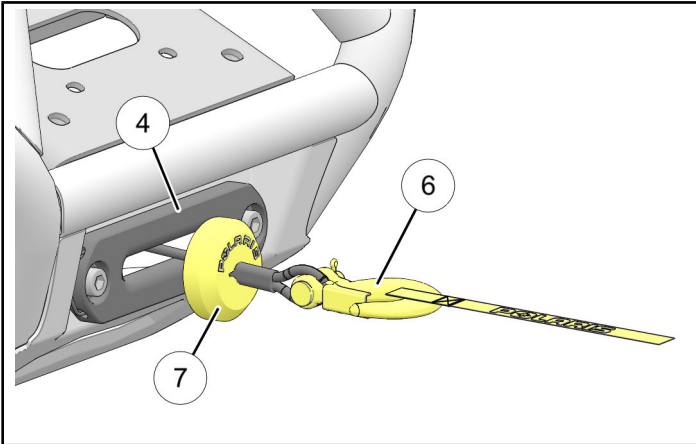

- c. Thread loop at end of rope through magnetic stop ⑦. Ensure stop is oriented with WIDE (magnet) end towards fairlead ④, and BEVELED end (“POLARIS”) towards hook ⑥.

TIP

Loop a cable tie to end of rope, but do not tighten. Thread looped cable tie through magnetic stop, then pull cable tie and rope through magnetic stop.

- d. Install hook ⑥ to loop at end of rope using clevis pin, then secure with cotter pin.
- e. Install winch assembly ① to bumper mounting bracket using four screws ②. Ensure proper orientation: Gear selector knob is on LH side of bumper as shown. Tighten screws.

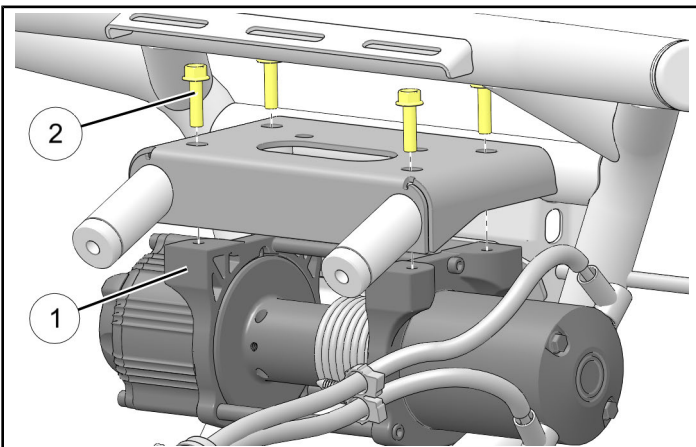

- f. Install bumper (and winch) to vehicle.

CAUTION

Bumper and winch weigh approximately 33 lbs. (15 kg). Provide adequate support or a second person for installation. Failure to comply may result in personal injury or damage to bumper or winch.

If bumper was NOT previously installed then install per instructions included with bumper kit. When bumper installation is complete (including installation of bumper support bracket below regulator) then return to Step 6 in this instruction.

If bumper was previously installed then proceed as follows:

- i. Loosely install upper end of bumper to vehicle frame using two each retained screws ①. See Step 4b.
- ii. Install tow hook ② and lower end of bumper to vehicle frame using two each retained screws ③. See Step 4a.

TIP

Front tow hook is retained by backer plate that loosely hangs from chassis structure. Hold backer plate in place while FULLY INSTALLING one screw. If first screw is not fully installed then rearward force may dislodge plate during installation of second screw.

- iii. Torque fasteners ④ and ⑤ to the same specification.

TORQUE

40 ft. lbs. (54 Nm) ± 10%

6. Install contactor/autostop bracket.
 - a. Remove starter solenoid ① from vehicle by removing two each screws ② and nuts ③. Retain screws and nuts.

IMPORTANT

Do NOT detach battery or starter cables, or remove chassis harness connector.

NOTE

Wheel hidden for clarity.

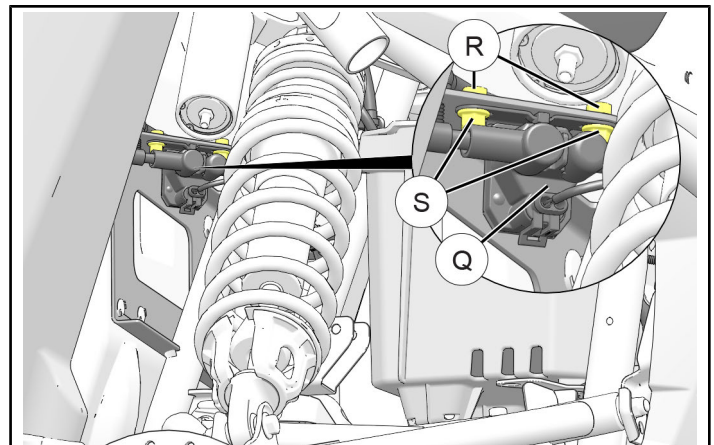

- b. Nest starter solenoid ⑩ below flange on contactor/autostop bracket ⑪, then install both solenoid and bracket to vehicle using two each retained screws ⑫ and nuts ⑬.

NOTE

Wheel and front suspension components hidden for clarity.

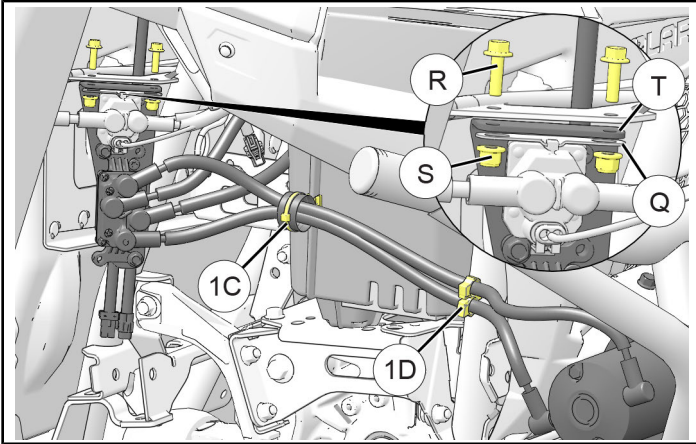

- c. Secure winch-to-contactor cables to RH side of battery box using edge clip 1C, and to vertical frame tubing using routing clip 1D.

7. Install wireless components.

- a. Install wireless receiver ⑪ to RH vertical frame tubing using two each brackets ⑨, screws ⑩, and nuts ⑧.

NOTE

Harness will be connected in Step 8.

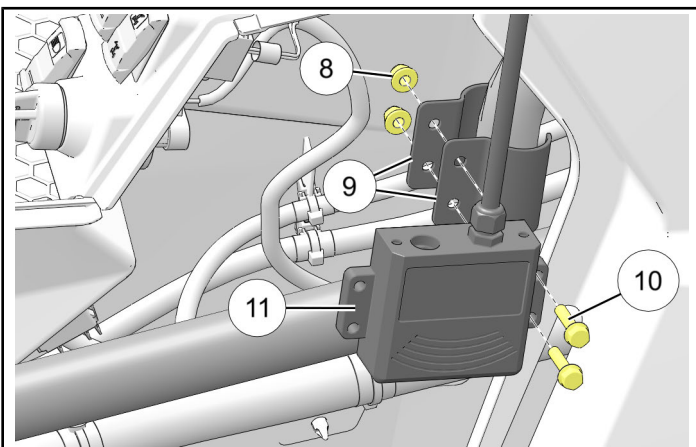

- b. Install wireless remote.

- i. Remove wireless remote ⑬ from holder ⑮. Determine suitable mounting location for holder with special attention to the following:

- Driver operation of vehicle
- Driver visibility
- Adequate clearance between holder attach fasteners and other vehicle components on underside of mounting surface

NOTE

Suggested mounting location shown.

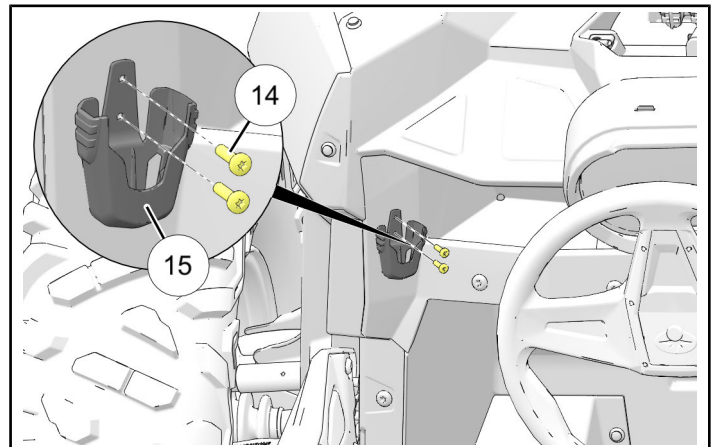

- ii. Using holder ⑮ as template, mark and drill two 1/8 inch (3 mm) holes into mounting surface.

IMPORTANT

Control drill depth to prevent damage to underlying structure or components.

- iii. Install holder ⑮ using two screws ⑭. Do not over-tighten screws.
iv. Reinstall wireless remote ⑬ into holder.

8. Route control harness.

NOTE

See previous section, **HARNESSES DETAIL**, for connector identification.

- a. Route terminal block connector 12A on control harness ⑫ from under-hood compartment rearward through firewall grommet ⑩ into under-dash compartment, then upward towards terminal block.

NOTE

All other harness components 12B through 12H remain on forward side of firewall grommet. Grommet may be temporarily removed to facilitate harness passage.

TIP

Access firewall grommet either through LH wheel well, or through under-hood compartment. Access will be difficult through RH wheel well.

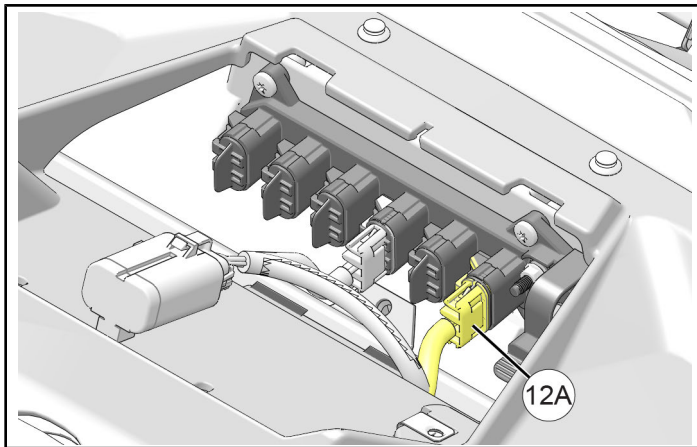
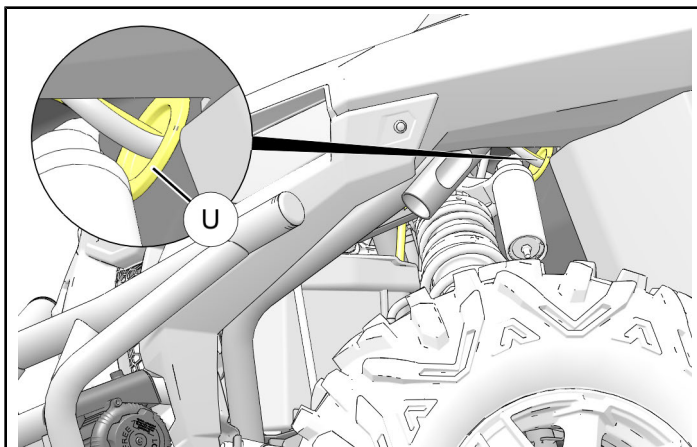

- b. Open power cap on vehicle terminal block at any open location, then plug in connector 12A.

- c. Route wireless receiver connector 12H on control harness ⑫ from firewall grommet ⑩ towards RH side of chassis, then downwards to wireless receiver ⑪.

NOTE

Right front fender shown partially transparent, and right front wheel hidden, for clarity

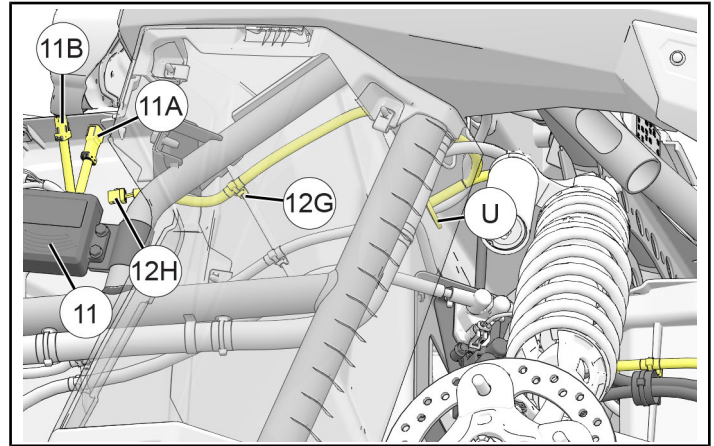

- d. Ensure routing will prevent contact with hot components, sharp edges, or moving parts, then join wireless receiver connector 12H to wireless receiver connector 11A.

NOTE

Wireless receiver connector 11B is unused.

- e. Secure control harness ⑫ to interior panel using edge clip 12G. Coil excess harness length from wireless receiver and secure to frame as required.
- f. Route connectors 12C, 12D, and 12F on control harness ⑫ from firewall grommet downward towards upper right rear corner of battery box ⑤.

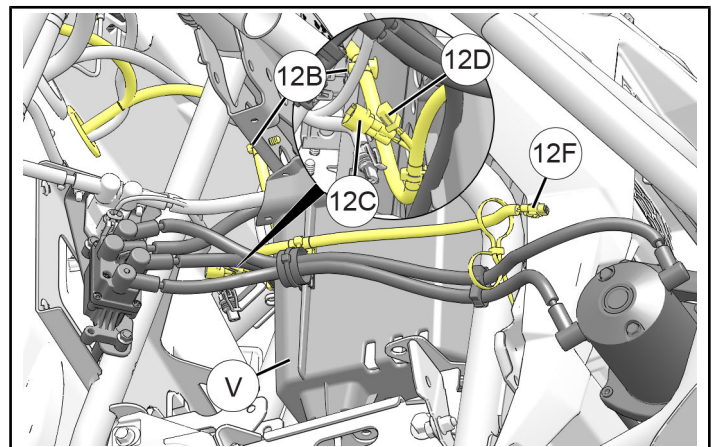

- g. Ensure routing will prevent contact with hot components, sharp edges, or moving parts, then secure control harness ⑫ to upper shock mount structure using routing clip 12B.

- h. Ensure routing will prevent contact with hot components, sharp edges, or moving parts, then join the following connectors:
 - i. 12C on control harness ⑫ to 1E on winch harness ①
 - ii. 12D on control harness ⑫ to 1H on winch harness ①
 - iii. 12F on control harness ⑫ to 4A on autostop fairlead harness ④

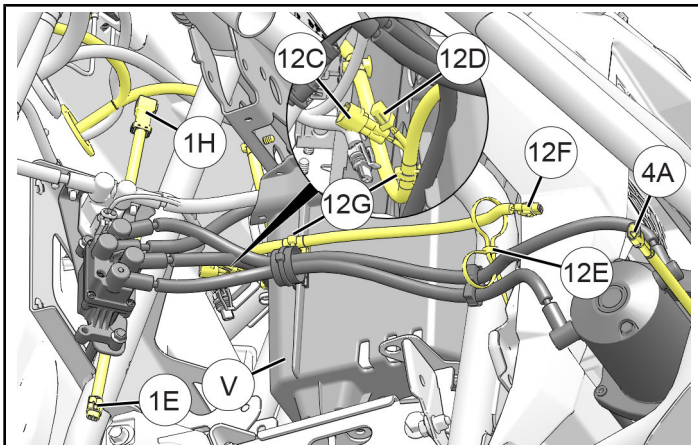

- i. Secure control harness ⑫ to the following components as follows:
 - i. Battery box ⑤ using two edge clips 12G
 - ii. Winch-to-contactor cables using double loop cable tie 12E

9. Restore access (all except under-hood storage compartment and hood). See Step 3 for detail.

10. Route battery cables.

⚠ WARNING

When BOTH battery cables are disconnected **ALWAYS** reconnect AND tighten red positive (+) cable to battery **FIRST**. Failure to comply will result in high current electrical arc, and may result in battery explosion, if tool touches grounded frame. Death or serious personal injury may occur.

NOTE

See previous section, **HARNESSES DETAIL**, for connector identification.
Clean existing battery cable lugs and/or battery terminals as required.

- a. Route **RED** battery cable ⑥ inboard from contactor, then through cut-out in **RIGHT** rear corner of battery box towards **BATTERY POSITIVE (+)** terminal.

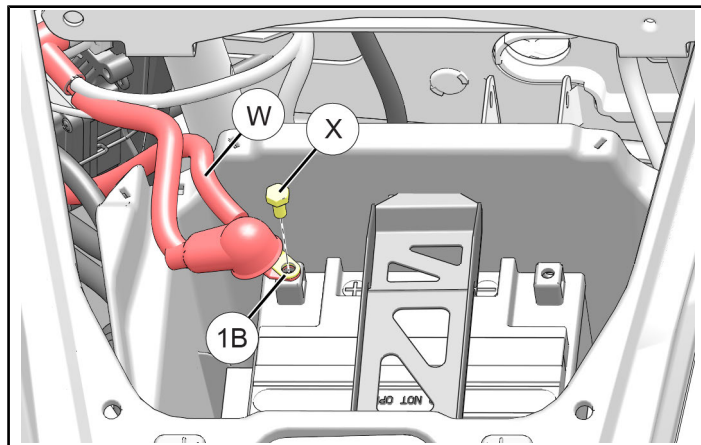

- b. Detach red terminal boot, then remove screw ⑩. Install existing vehicle battery cable lug AND connector 1B (**RED** battery cable ⑥) to **BATTERY POSITIVE (+)** terminal using screw. Torque to specification. Reinstall red terminal boot.

TORQUE

6 ft. lbs. (8 Nm) ± 10%

- c. Route **BLACK** battery cable ⑦ inboard from contactor, then through cut-out in **LEFT** rear corner of battery box towards **BATTERY NEGATIVE (-)** terminal.

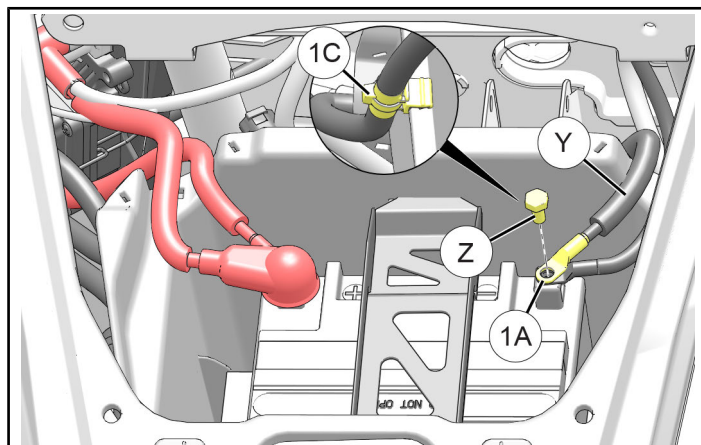

- d. Remove screw ⑪. Reinstall existing vehicle battery cable AND connector 1A (**BLACK** battery cable ⑦) to **BATTERY NEGATIVE (-)** terminal using screw. Torque to specification.

TORQUE

6 ft. lbs. (8 Nm) ± 10%

- e. Secure **BLACK** battery cable ⑦ to rear side of battery box using edge clip 1C.
- f. Reinstall under-hood storage compartment and hood.

OPERATION

OPERATIONAL CHECK (ALL WINCHES)

Wireless remote allows winch operation from outside the vehicle. If winch does not operate as described, refer to the **TROUBLESHOOTING** section.

IMPORTANT

The Autostop system is intended to prevent winch damage caused by over-tightening the rope, but cannot prevent all possible winch damage. The winch system is very powerful and care should be exercised whenever it is in operation.

The winch operator is always responsible for using the winch properly, as described in the accompanying "Winch User Guide". The Autostop system should only be used as a secondary preventive measure to help prevent damage to the winch from over-tightening the rope.

1. To turn wireless remote "ON", depress and hold power button for three seconds or until LED light illuminates.
2. To extend rope, depress and hold the "OUT" button. To recover rope, depress and hold the "IN" button.

IMPORTANT

During rope retraction the winch should automatically stop when the magnetic stop ⑦ comes close to or contacts the autostop fairlead ④ (within approximately 1 inch (25 mm)). Magnets in the stop trigger sensors in the fairlead, stopping the winch.

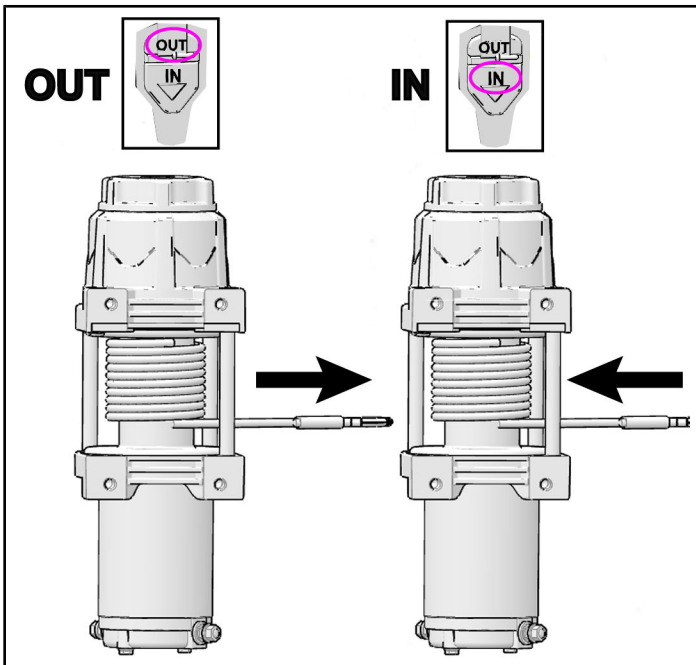

3. The wireless remote will automatically turn "OFF" after 30 seconds of inactivity. To manually turn off, depress and hold power button for three seconds or until LED light extinguishes.

GEAR SELECTION (SINGLE SPEED WINCH KIT 2882708)

WARNING

Do NOT attempt to change gear setting while rope is under tension. Failure to relieve rope tension prior to changing gears may result in winch failure, resulting in serious personal injury or death.

NOTE

See Kit Contents for replacement knob PN.

Your winch is equipped with two different gear settings: "FREE" and "LOCK".

1. FREE: Used to rapidly extend the rope (faster than when in the "LOCK" position).
2. LOCK: Used to recover the rope.

To shift between FREE and LOCK relieve all tension from the rope, then rotate gear selector knob (located on end of winch) clockwise to engage LOCK mode, or counterclockwise to engage FREE mode.

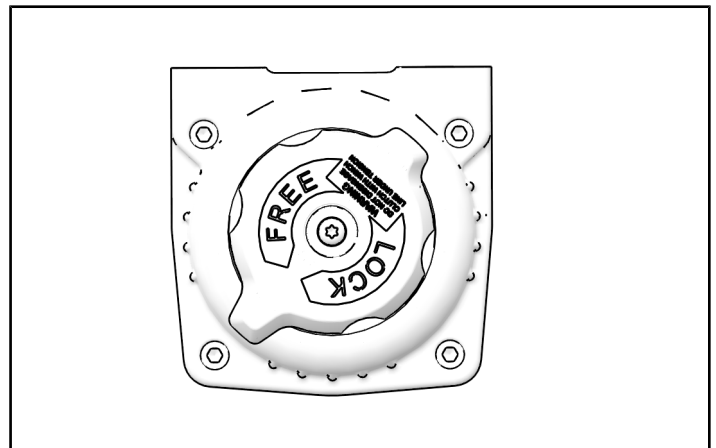

GEAR SELECTION (RAPID ROPE RECOVERY WINCH KIT 2883825)

⚠ WARNING

Do NOT attempt to change gear setting while rope is under tension. Failure to relieve rope tension prior to changing gears may result in winch failure, resulting in serious personal injury or death.

NOTE

See Kit Contents for replacement knob PN.

Your winch is equipped with three different gear settings: "N" (NEUTRAL), "L" (LOW), and "H" (HIGH).

1. NEUTRAL: Used to rapidly extend the rope.

When in neutral "N" will be visible in the cutout window on the shift knob (LH side of winch).

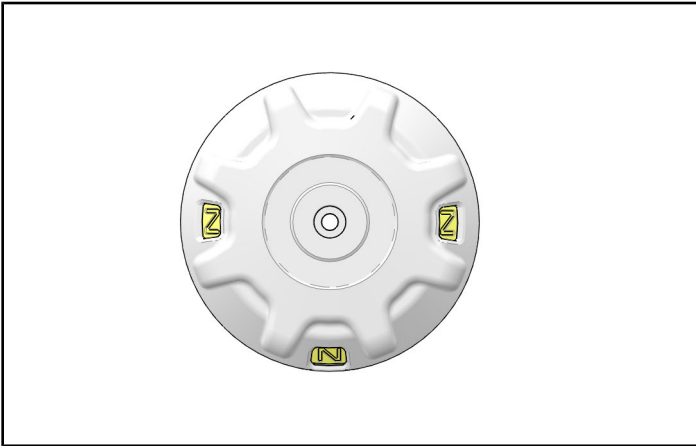

2. LOW: Used to recover the LOADED rope.

Relieve all tension from the rope, then rotate gear select knob counter-clockwise until "L" is visible in the shift knob cutout window.

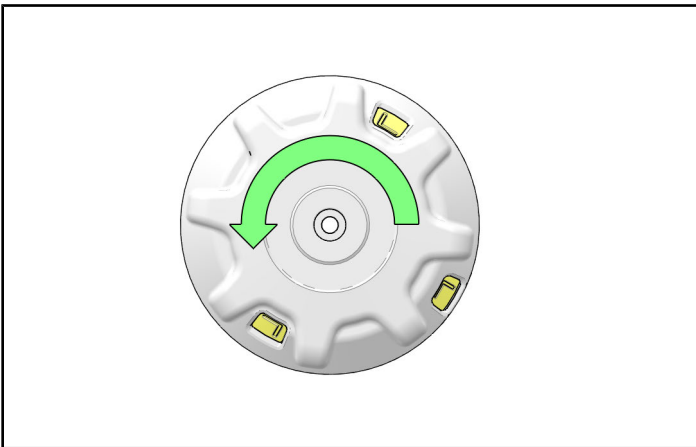

3. HIGH: Used to rapidly recover the UNLOADED rope.

Relieve all tension from the rope, then rotate gear select knob clockwise until "H" is visible in the shift knob cutout window.

If difficulty is encountered while shifting into HIGH, pull the winch rope slightly by hand to help align the gears.

IMPORTANT

High gear is ONLY used for rapid recovery of the UNLOADED winch rope. It is NOT intended for rope retraction while under load. Using high gear while under load will result in reduced winch life.

NOTE

The recovery speed in HIGH gear is approximately 5X the recovery speed in LOW gear. As a result, using this feature will significantly reduce the time needed to recover the rope after use.

Polaris recommends always returning gear selector to LOW after rapid recovery to prevent inadvertent future operation in HIGH gear.

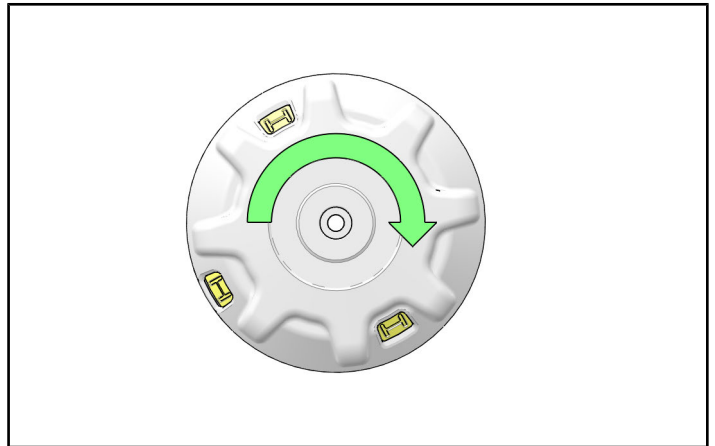

TROUBLESHOOTING

SYMPTOM	POSSIBLE CAUSES	RECOMMENDED SOLUTION
Dead vehicle battery	Incorrect, damaged, or corroded electrical connections	Verify all winch electrical connections are per instruction manual and free of damage and/or corrosion.
Winch will not operate	Contactors not receiving power	Turn vehicle key on.
	Wireless remote not powered on	Turn wireless remote on.
	Incorrect, damaged, or corroded electrical connections	Verify all winch electrical connections are per instruction manual and free of damage and/or corrosion.
	Keyed power circuit (orange wires) not properly powered	Check 10A accessory circuit fuse for continuity; replace as required.
Winch operates in one direction only	Autostop fairlead not properly connected	If winch operates only outward then ensure magnetic stop (black rubber puck) is not touching autostop fairlead. If winch operates inward even when magnetic stop is touching fairlead then verify all winch electrical connections are per instruction manual and free of damage and/or corrosion.
Winch makes noise but rope does not move	Contactors powered, but not winch	If clicking sound is heard when winch control button is depressed, but winch motor is silent, then verify electrical connections between winch and contactors are free of damage and/or corrosion. If winch makes noise but does not move, verify winch is in gear. If winch is in gear, but winch still does not move, have a dealer inspect the winch.
	Winch not in proper gear	Rotate gear knob fully into L or H, then recheck.
Winch operates too slowly	Winch is improperly loaded	Verify rope is not binding on spool or fairlead. IMPORTANT Rapid Rope Recovery Winch Kit 2883825: High gear is ONLY used for rapid recovery of the UNLOADED winch rope. It is NOT intended for rope retraction while under load. Using high gear while under load will result in reduced winch life.
	Rapid Rope Recovery Winch Kit 2883825: Winch not in proper gear	Rotate gear knob fully into L or H, then recheck. NOTE Winch is designed to operate slowly in low gear.
Winch will not change gears	Rope is under load	Changing gears while under load is intentionally difficult to prevent accidental operation, which could lead to personal injury or winch failure. Ensure rope is under no tension, and rope is not binding on spool or fairlead. Briefly operate winch, then attempt to shift again.

FEEDBACK FORM

A feedback form has been created for the installer to provide any comments, questions or concerns about the installation instructions. The form is viewable on mobile devices by scanning the QR code or by clicking [HERE](#) if viewing on a PC.

