

LIGHT HARNESS KIT



P/N 2883388

APPLICATION

Verify accessory fitment at Polaris.com.

BEFORE YOU BEGIN

Read these instructions and check to be sure all parts and tools are accounted for. Please retain these installation instructions for future reference and parts ordering information.

KIT CONTENTS

This kit contains parts for installation of the Light Harness only. Prior installation of a light kit is also required (sold separately).

This Kit includes:

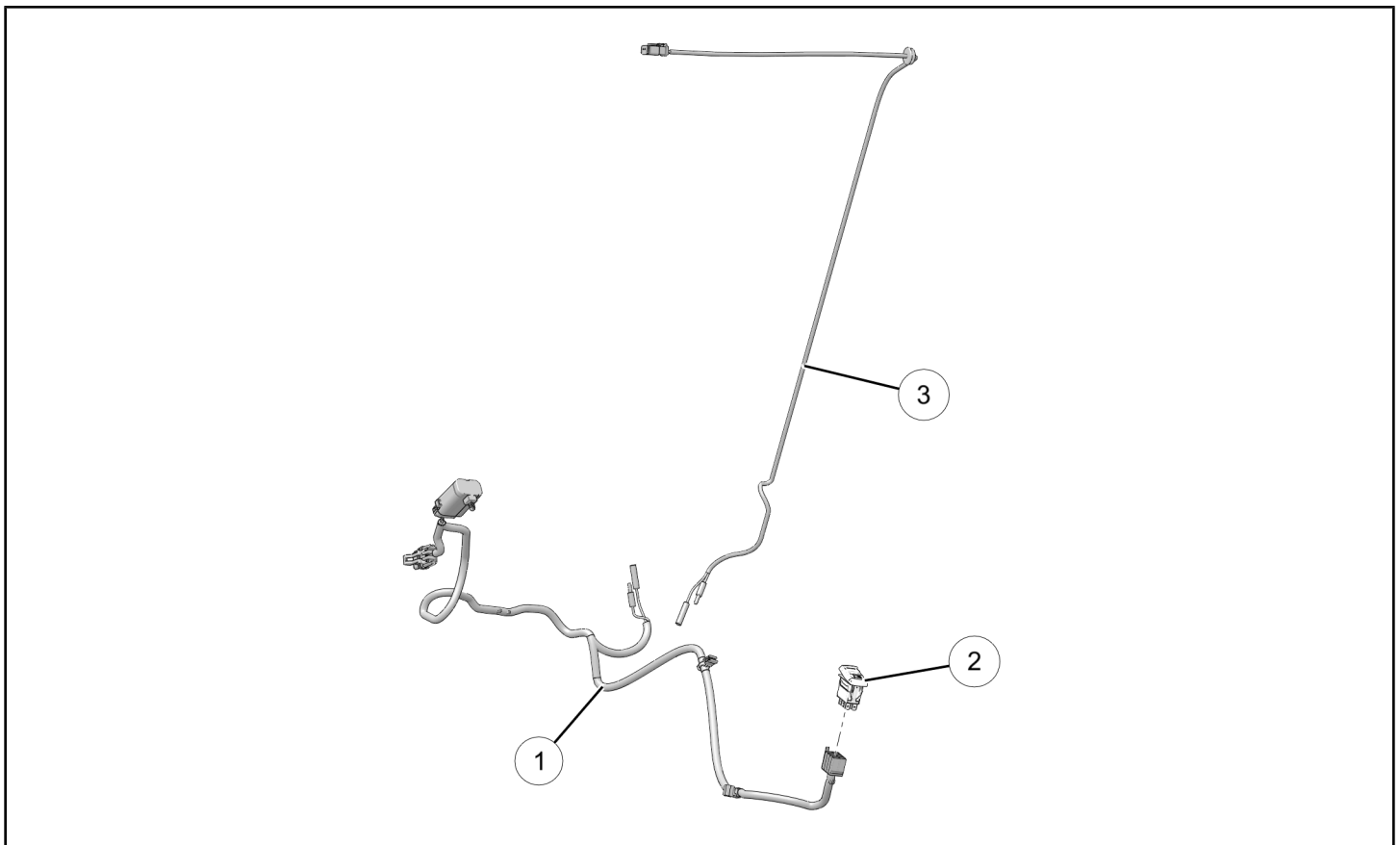

REF	QTY	PART DESCRIPTION	PART NUMBER
1	1	Harness, Dash	2414102
2	1	Switch	4014558
3	1	Harness, ROPS	2412616
4	5	Cable Tie (not shown)	7080492
	1	Instructions	9928537

TOOLS REQUIRED

- Safety Glasses
- Cutting Tool
- Deburring Tool
- Screwdriver Set, Torx®

IMPORTANT

Your Light Harness Kit is exclusively designed for your vehicle. Please read the installation instructions thoroughly before beginning. Installation is easier if the vehicle is clean and free of debris. For your safety, and to ensure a satisfactory installation, perform all installation steps correctly in the sequence shown.

ASSEMBLY TIME

Approximately 25 minutes

HARNESS DETAIL

DASH HARNESS ①:

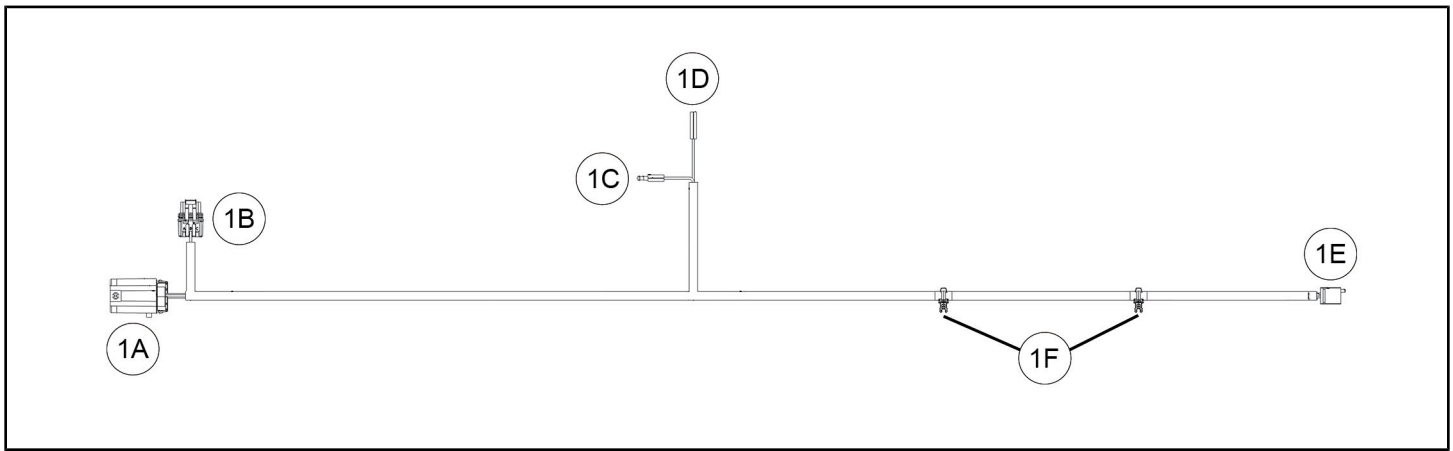

REF	PART DESCRIPTION	WIRE COLOR	PIN QTY/ GENDER	CONNECTS TO
1A	Relay/Fuse Block	-	-	Vehicle structure
1B	Connector, Terminal Block	-	3 female	Vehicle terminal block
1C	Connector, Bullet, Light Ground	Brown	1 male	ROPS harness ③, connector 3B
1D	Connector, Bullet, Light B+	Red	1 female	ROPS harness ③, connector 3C
1E	Connector, Switch	-	8 female	Switch ②
1F	Clip, Edge	-	-	Vehicle structure

ROPS HARNESS ③:

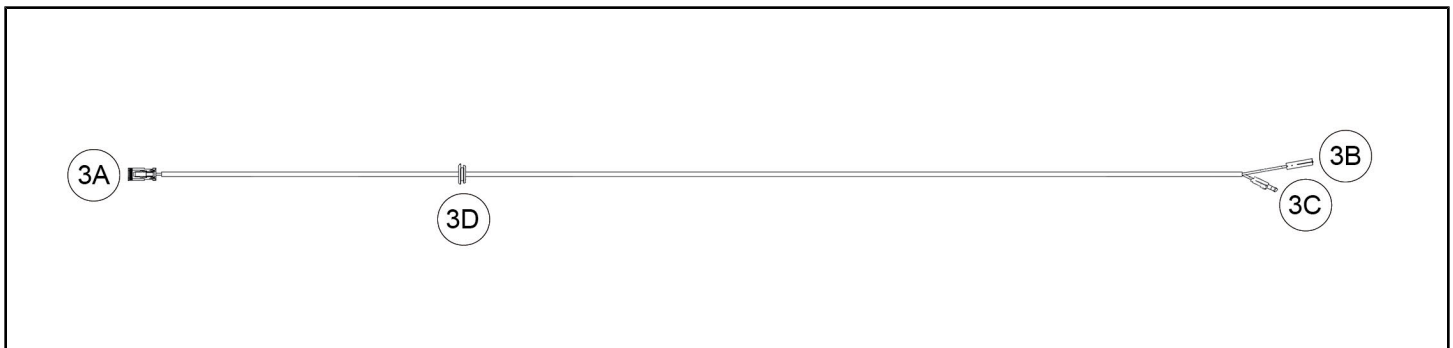

REF	PART DESCRIPTION	WIRE COLOR	PIN QTY/ GENDER	CONNECTS TO
3A	Connector, Light	-	2 female	Light Bar Kit (sold separately)
3B	Connector, Bullet, Light Ground	Brown	1 female	Dash harness ①, connector 1C
3C	Connector, Bullet, Light B+	Red	1 male	Dash harness ①, connector 1D
3D	Grommet, ROPS	-	-	Vehicle structure

INSTALLATION INSTRUCTIONS

- Shift vehicle transmission into "PARK". Turn key to "OFF" position and remove from vehicle.
- Gain access.
 - Remove visor by removing two screws (A). Retain screws.

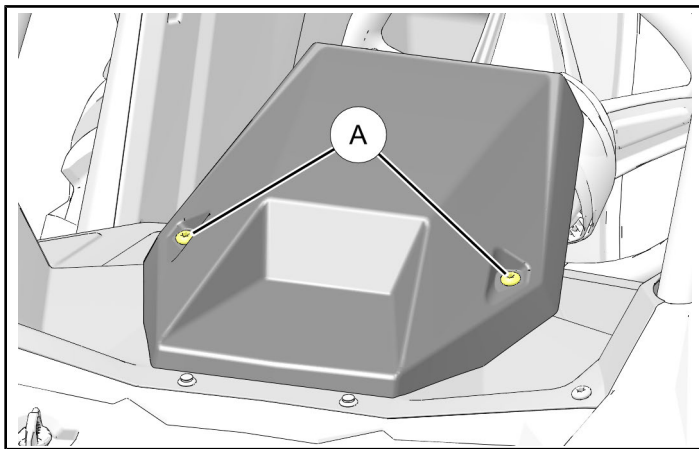

- Remove RH A-pillar access cover (B) by grasping rear inboard corner of cover with fingers, then lift to detach three locking tabs (C), two posts (D), and two locking tabs (E). Set cover aside.

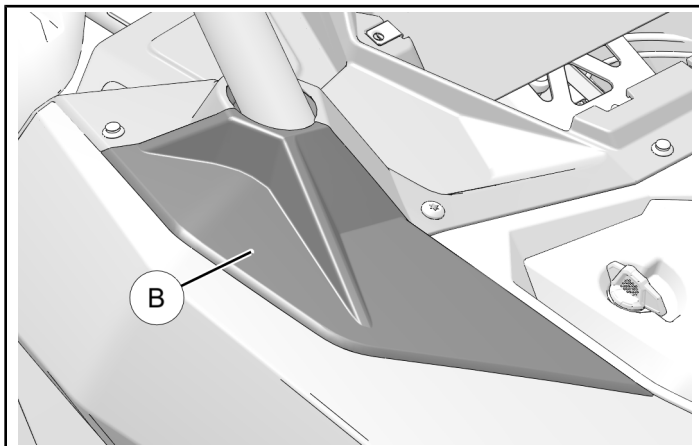

NOTE

View of underside of cover looking rearward.

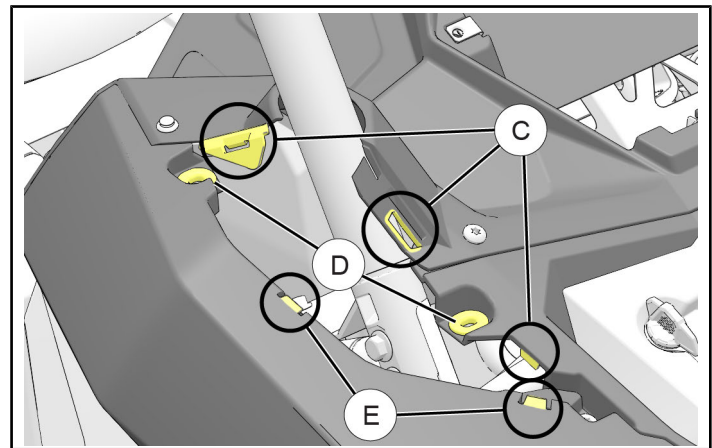
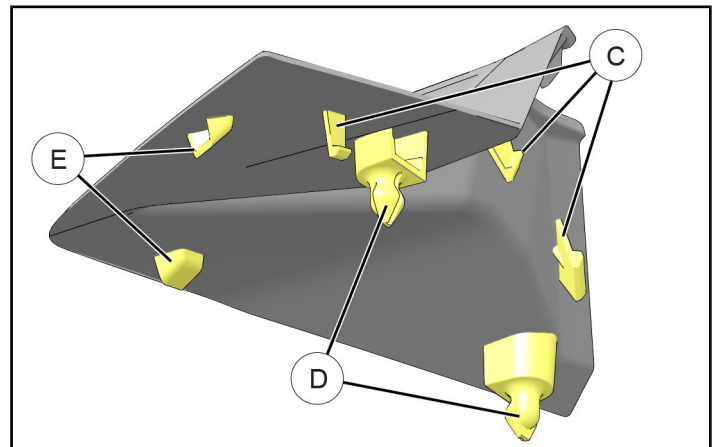

- c. Remove RH rear fender by unlocking quarter turn latch (F) and unhooking two straps (G).

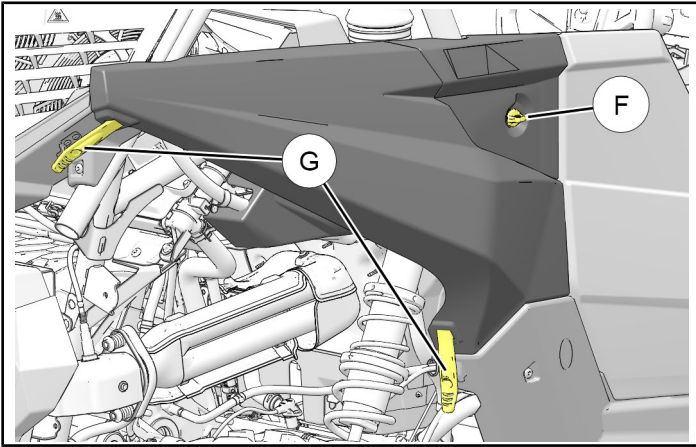

- d. Remove five screws (H) securing exterior body panel to frame. Retain screws.

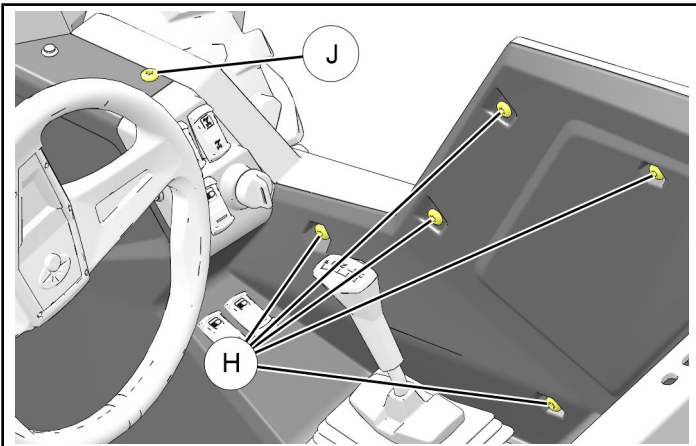

- e. From outside of vehicle, and while supporting exterior body panel, remove final screw (J), then remove panel by detaching locking tab (K) from mating slot (L) in front fender. Set panel aside.

NOTE

View of outer RH door panel, interior side.

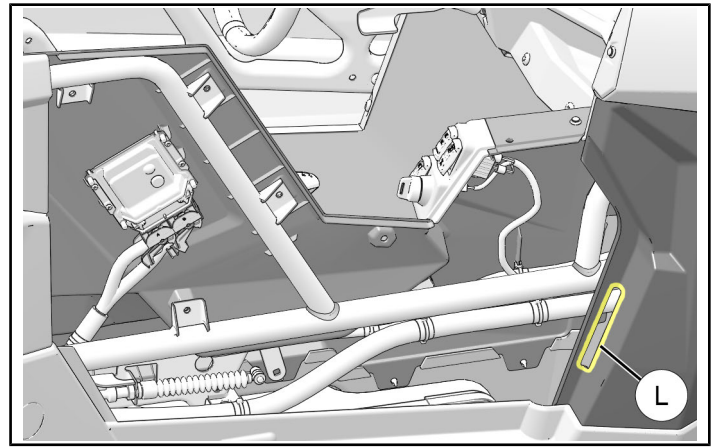
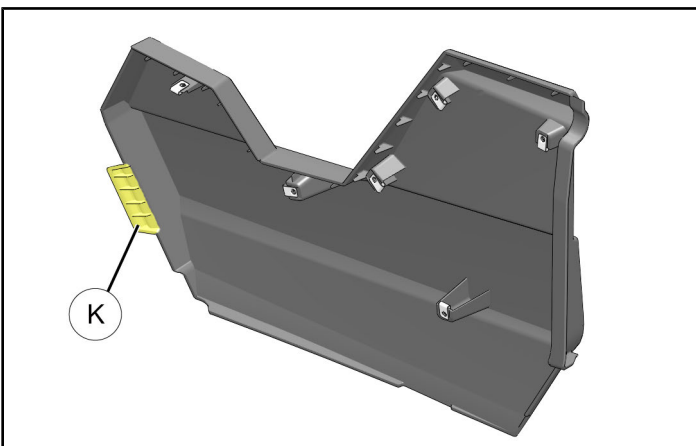

3. Install ROPS harness.

NOTE

See previous section, **HARNESSES DETAIL**, for connector identification.

- a. Route two bullet connectors 3B and 3C on ROPS harness (3) into hole at top of RH side A-pillar, down ROPS, and out of welded coupler at base of pillar.

NOTE

Connection to dash harness will occur in Step 4d.

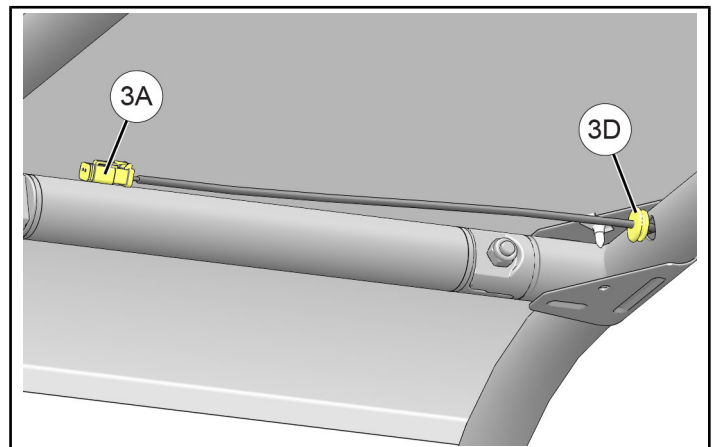

- b. Install grommet 3D in hole at top of RH side A-pillar.
 c. Join light connector 3A to mating light connector (light sold separately).
 d. Secure ROPS harness (3) using cable ties (4) to prevent contact with hot components, sharp edges, or moving parts.

4. Install dash harness.

NOTE

See previous section, **HARNES DETAIL**, for connector identification.

- a. Install relay/fuse block 1A on dash harness ① to upper dash panel using attached fir tree clip.

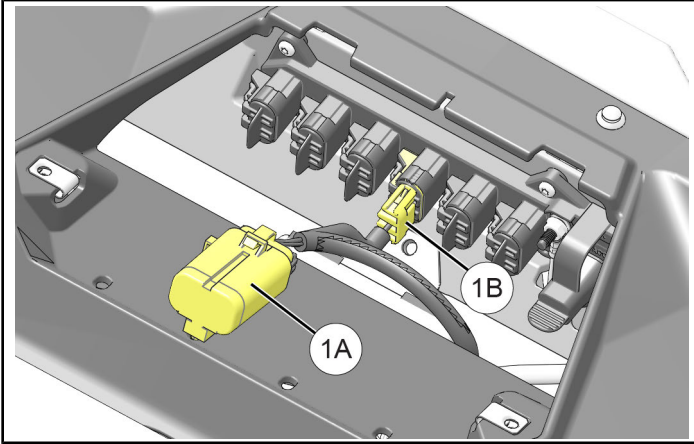

- b. Open power cap on vehicle terminal block at any open location, then plug in connector 1B.
- c. Route opposite end of harness ① beneath upper dash panel towards base of RH ROPS A-pillar.

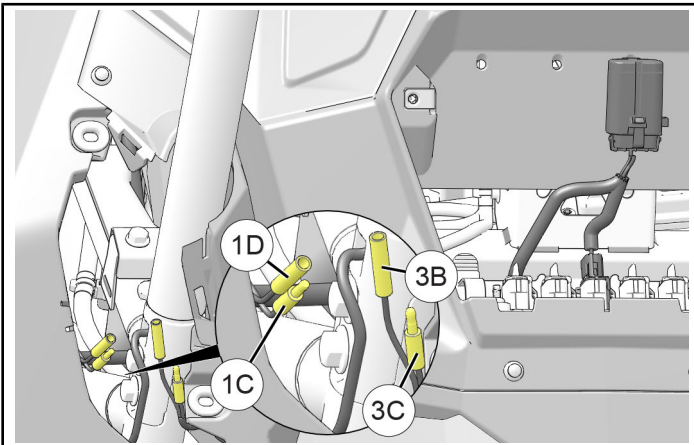

- d. Join two bullet connectors 1C and 1D on dash harness ① to mating bullet connectors 3B and 3C on ROPS harness ③, matching wire colors (red to red, and brown to brown).
- e. Carefully cut out one rectangular switch blank ① from RH console panel. Deburr hole edges as required.

IMPORTANT

Control cut depth to prevent damage to underlying structure or components.

NOTE

Any open location may be used.

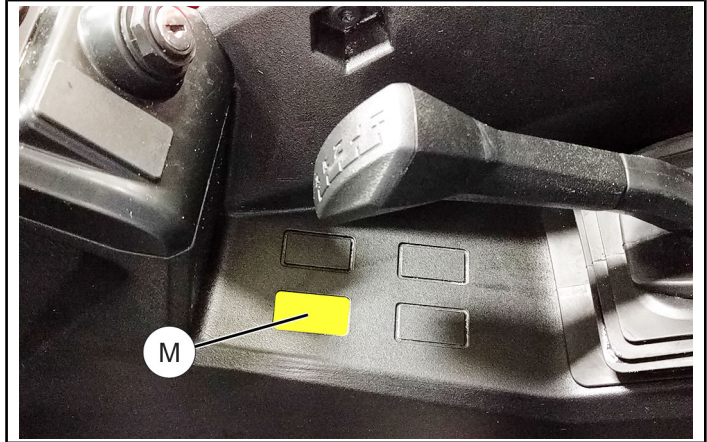

- f. Route connector 1E upward through switch opening, join to switch ②, then install switch into panel.
- g. Secure upper edge clip 1F to horizontal support member (inboard of chassis tubing), and lower edge clip 1F to panel flange.

TIP

Upper edge clip 1F can be installed by reaching down through A-pillar access cover opening.

NOTE

Front fender hidden for clarity.

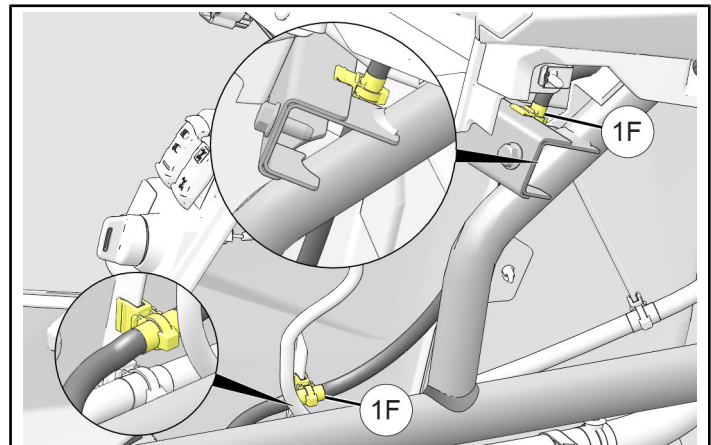

- h. Secure harness ① using cable ties ④ to prevent contact with hot components, sharp edges, or moving parts.

5. Restore access.

FEEDBACK FORM

A feedback form has been created for the installer to provide any comments, questions or concerns about the installation instructions. The form is viewable on mobile devices by scanning the QR code or by clicking [HERE](#) if viewing on a PC.

